



SCIGATE AUTOMATION (S) PTE LTD

Bukit Batok Street 22 #01-01 Singapore 659592

Tel: (65) 6561 0488

Fax: (65) 6561 0588

Email: sales@scigate.com.sg

Web: <https://scigate.com.sg/>

Business Hours: Monday - Friday 8:30AM - 6:15PM

More Precision

scanCONTROL // 2D/3D laser scanners (laser profile sensors)





- Ideal for precise 2D/3D measurements
- Resolution (x-axis) up to 1,280 points
- Profile frequency up to 2,000 Hz
- Also available with patented Blue Laser Technology

Compact design for precise measurement tasks

The design of the LLT 29xx series is focused on compact size and low weight. The controller is integrated in the housing, simplifying cabling arrangements and mechanical integration. Due to its compact design and the high profile resolution, the LLT29xx series is especially suitable for static, dynamic and robotic applications.

Interfaces for universal integration

The multi-function port can be used for power supply, as data output, for switching parameters, as trigger input or for synchronizing several scanCONTROL sensors. During synchronous operation, an integrated mode can be used to operate the sensors alternately compensating for overlapping laser lines. One scanner is measuring whilst the other laser line is switched off. The scanners can be supplied via Ethernet if necessary. If Industrial Ethernet is used as data output, only one cable will remain that connects the sensor to the periphery. For all SMART sensors, the measurement data output can be carried out in three different ways, e.g., via Ethernet UDP, Modbus TCP or serial. Micro-Epsilon converters enable data transmission via analog signals, digital switching signals, PROFINET, Ethernet/IP or EtherCAT.

Small measuring range with high resolution

With a laser line of just 10 mm, the LLT29xx-10/BL models recognize the finest of details and structures. The high profile resolution combined with the blue laser line allow for maximum precision destined for versatile applications, e.g., in the electronics production.

Available with patented Blue Laser Technology

The Blue Laser technology uses a laser diode with a shorter wavelength of 405 nm. The outstanding characteristics of this wavelength range enable measurements on red-hot glowing metals, (semi-)transparent and organic objects.

Article designation

LLT	29	00	-25	/SI	
Options - see below					
Measuring range					
10 mm (only Blue Laser)					
25 mm					
50 mm					
100 mm					
Class					
00=COMPACT					
10=SMART					
50=HIGHSPEED					
60=HIGHSPEED SMART					
Series					
LLT29xx					

Laser options*

	/SI	Hardware switch-off of the laser line
	/3B	Improved laser power (class 3B, ≤ 20 mW), e.g., for dark surfaces
	/BL	Blue laser line (405 nm) for (semi-) transparent, red-hot glowing and organic materials

Cable output options*

	/PT	Cable directly out of the sensor ("Pigtail") Length 0.25 m
	/VT	Cable directly out of the sensor ("Variable Tail") Length 0.1 ... 1.0 m (freely selectable)
	/ST	1 cable directly out of the sensor ("Single Tail") multi-function port is omitted, Length 0.1 ... 1.0 m (freely selectable)

*Options can be combined

Model		LLT	29xx-10/BL	29xx-25	29xx-50	29xx-100
z-axis (height)	Standard measuring range	Start of measuring range	52.5 mm	53.5 mm	70 mm	190 mm
		Mid of measuring range	56.5 mm	66 mm	95 mm	240 mm
		End of measuring range	60.5 mm	78.5 mm	120 mm	290 mm
		Height of measuring range	8 mm	25 mm	50 mm	100 mm
	Extended measuring range	Start of measuring range	-	53 mm	65 mm	125 mm
		End of measuring range	-	79 mm	125 mm	390 mm
Linearity ¹⁾		(2 sigma)	±0.17 % FSO	±0.10 % FSO	±0.10 % FSO	±0.10 % FSO
Reference resolution ^{2) 3)}			1 μm	2 μm	4 μm	12 μm
x-axis (width)	Standard measuring range	Start of measuring range	9.4 mm	23.4 mm	42 mm	83.1 mm
		Mid of measuring range	10 mm	25 mm	50 mm	100 mm
		End of measuring range	10.7 mm	29.1 mm	58 mm	120.8 mm
	Extended measuring range	Start of measuring range	-	23.2 mm	40 mm	58.5 mm
		End of measuring range	-	29.3 mm	60 mm	143.5 mm
	Resolution (x-axis)			1,280 points/profile		
Profile frequency		Standard	up to 300 Hz			
		HIGHSPEED	up to 2,000 Hz			
Interfaces	Multi-function port	Ethernet GigE Vision	Output of measurement values Sensor control Profile data transmission			
		Digital inputs	Mode switching Encoder (counter) Trigger			
		RS422 (half-duplex) ⁴⁾	Output of measurement values Sensor control Trigger Synchronization			
Output of measurement values			Ethernet (UDP / Modbus TCP); RS422 (ASCII / Modbus RTU) analog ⁵⁾ ; switch signal ⁵⁾ PROFINET ⁶⁾ ; EtherCAT ⁶⁾ ; EtherNet/IP ⁶⁾			
Display (LED)			1x laser ON/OFF, 1x power/error/status			
Light source	Standard	Semiconductor laser 405 nm (blue)	Semiconductor laser 658 nm (red)			
	optional	-	Semiconductor laser 405 nm (blue)			
Aperture angle of laser line			10°	20°	25°	25°
Laser power	Standard		≤ 8 mW (laser class 2M)			
	optional	-	≤ 20 mW (laser class 3B)			
Laser switch-off	optional		Hardware safety switch-off			
Permissible ambient light (fluorescent light) ²⁾			10,000 lx			
Protection class (sensor)			IP65			
EMC requirements			according to: EN 61326-1: 2006-10 DIN EN 55011: 2007-11 (group 1, B class) EN 61000-6-2: 2006-03			
Vibration			2 g / 20 ... 500 Hz			
Shock			15 g / 6 ms			
Operating temperature			0 ... +45 °C			
Storage temperature			-20 ... +70 °C			
Dimensions			96 x 118.5 x 33 mm		96 x 85 x 33 mm	
Sensor weight (without cable)			440 g		380 g	
Supply			11 ... 30 VDC, nominal value 24 V, 500 mA, IEEE 802.3af class 2, Power over Ethernet			

¹⁾ Measuring range (standard)

²⁾ Measurement object: Micro-Epsilon standard object (metallic, diffusely reflecting material)

³⁾ According to a one-time averaging across the measuring field (640 points)

⁴⁾ RS422 interface, programmable either as serial interface or as input for triggering/synchronization

⁵⁾ Only with Output Unit

⁶⁾ Only with scanCONTROL Gateway

FSO = Full Scale Output

LLT29x0-10/BL

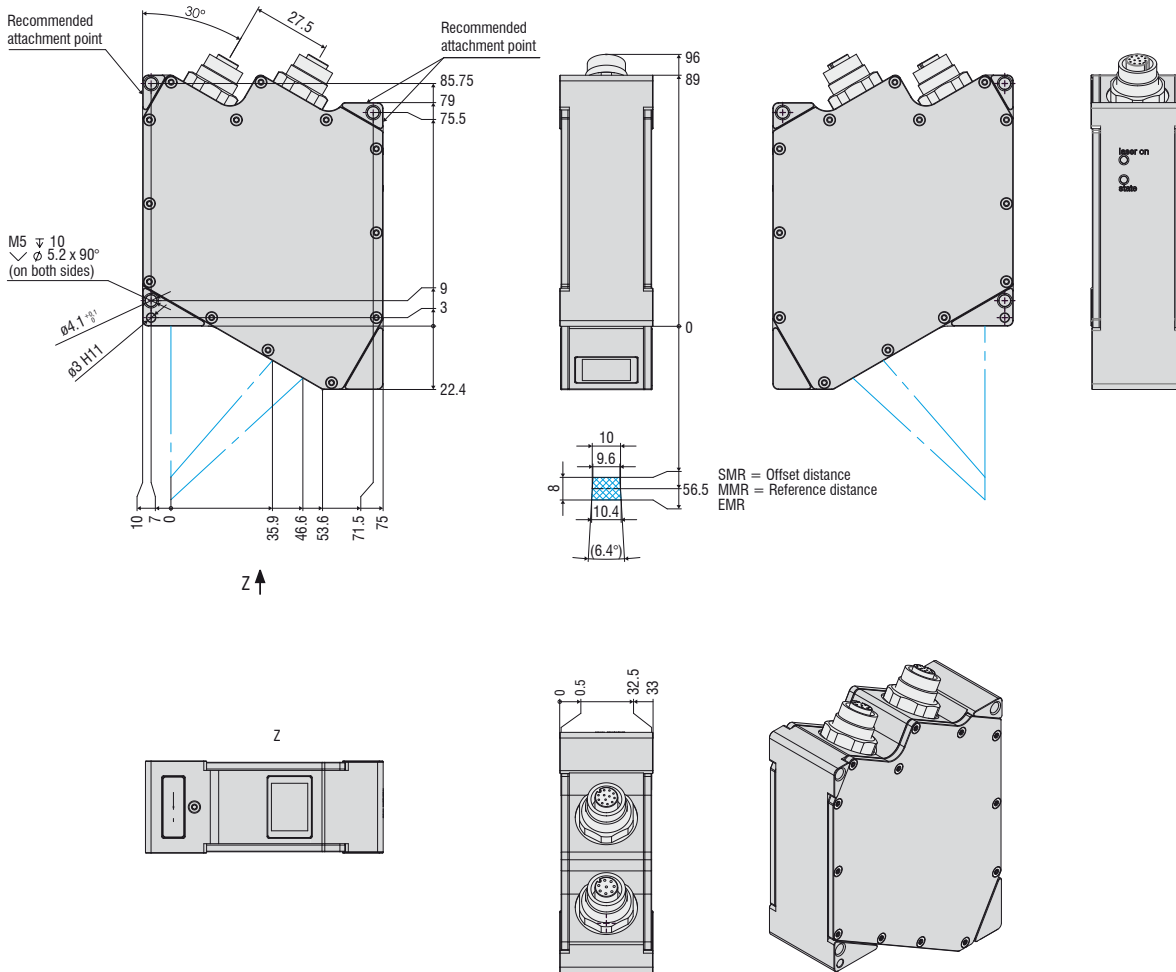

LLT25x0/LLT26x0/29x0-25

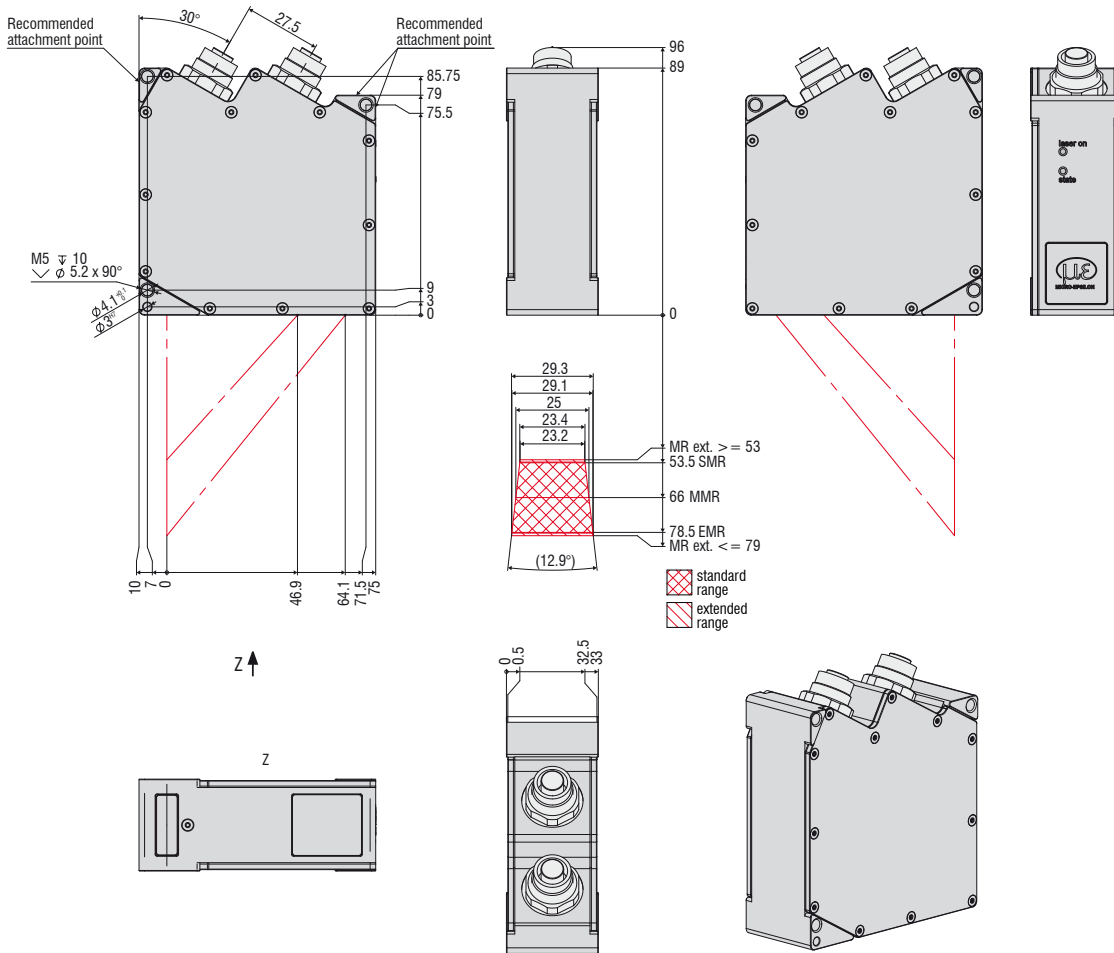

LLT25x0/LLT26x0/29x0-50

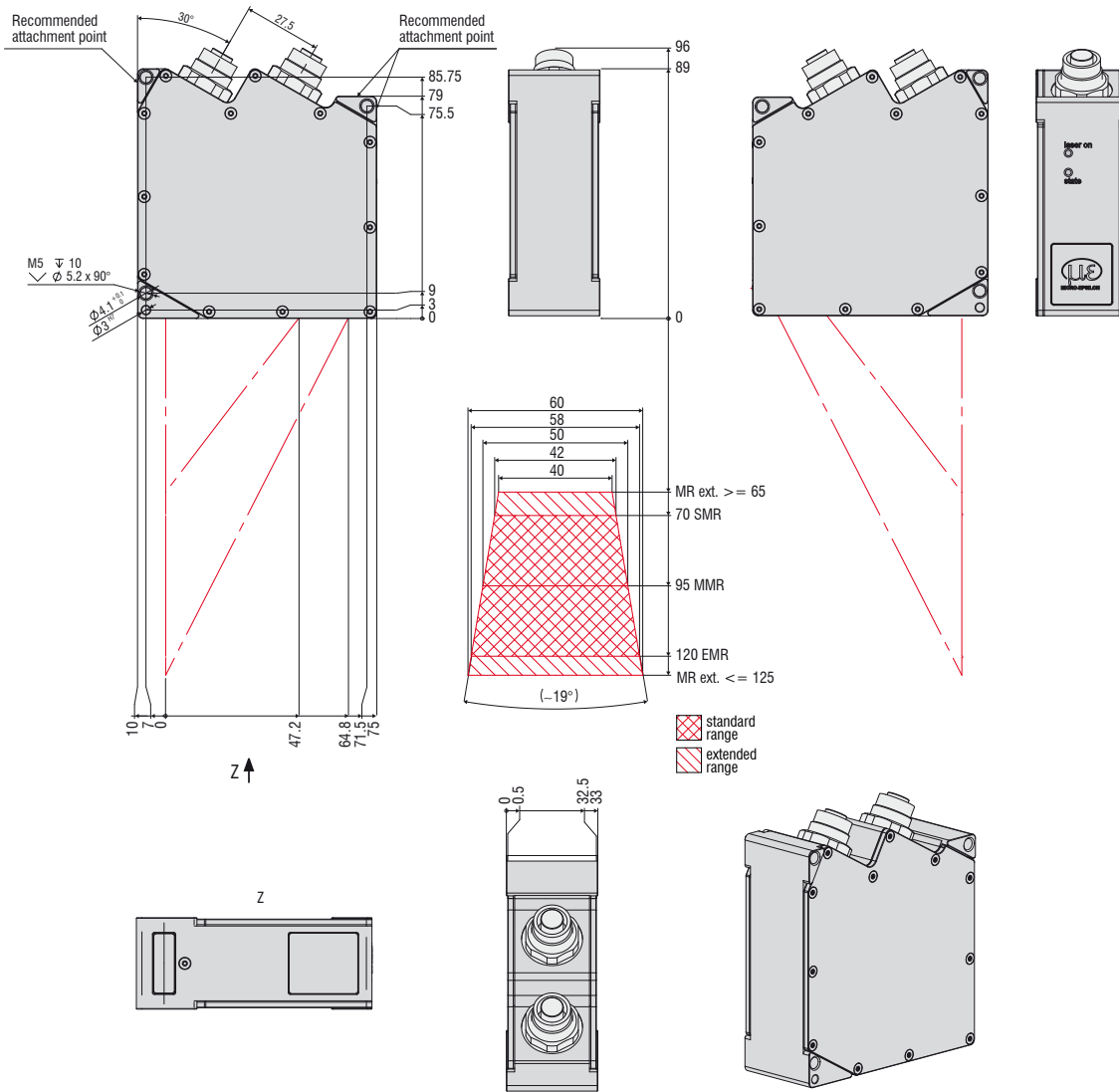

LLT25x0/LLT26x0/29x0-100

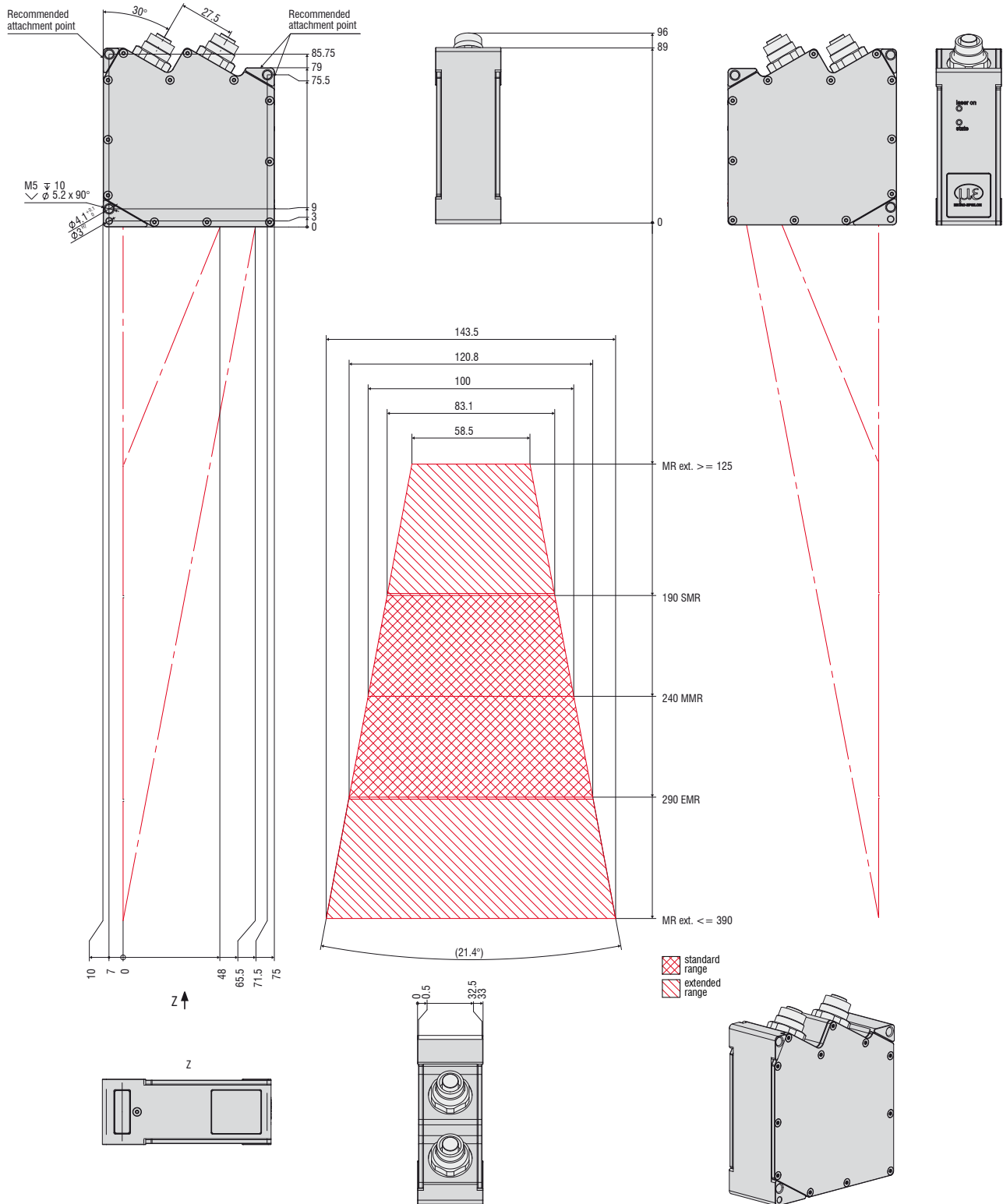

Sensors and Systems from Micro-Epsilon

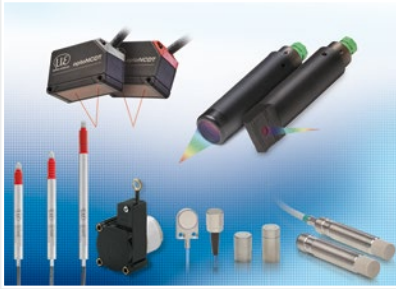

Sensors and systems for displacement, distance and position



Sensors and measurement devices for non-contact temperature measurement



Measuring and inspection systems for metal strips, plastics and rubber



Optical micrometers and fiber optics, measuring and test amplifiers



Color recognition sensors, LED analyzers and inline color spectrometers

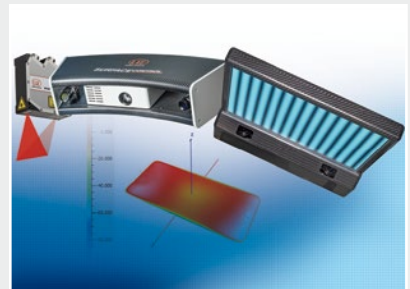

3D measurement technology for dimensional testing and surface inspection