

Meeting Harmonic Limits on Marine Vessels

I. C. Evans, A. H. Hoevenaars, P.Eng, *Member, IEEE*

Abstract—Recent advances in power electronic drive converters have led to an increased use of this technology for electric propulsion and other variable speed drive applications on marine vessels such as ships and offshore oil platforms. The current and voltage harmonics these devices introduce however have caused marine regulating bodies to introduce strict harmonic voltage limits to ensure that the reliability of equipment and the safety of crews are not compromised by their use. In order to meet these new standards, methods to control harmonics must be adopted. This paper will discuss some of these methods and present an application where a unique wide spectrum passive harmonic filter was used to meet harmonic limits on a cable laying ship that previously required the use of rented generators to allow operation of variable speed drives.

I. INTRODUCTION

The quality and security of its voltage supply is crucial to the safety of any marine vessel. With the increasing use of AC and DC electric drives for applications such as electric propulsion, this has become an even greater issue. Electric propulsion provides significant benefits, such as lower running costs, less maintenance, reduced manpower, greater redundancy, lower emissions, improved maneuverability (with podded or azimuth type propulsors) and increased cargo carrying capabilities. But by drawing current in a non-linear or non-sinusoidal manner, electric propulsion can introduce excessive levels of both current and voltage harmonics. Non-linear loading on marine vessels can now reach 80% of the onboard electrical generating capacity [1] and result in total harmonic voltage distortion (THDv) in excess of 20% (Fig. 1).

All marine classification bodies, including the American Bureau of Shipping (ABS), are extremely concerned about harmonic voltage distortion and the possible consequences should some critical item of equipment malfunction or fail. Often viewed as a potential SOLAS (Safety Of Life At Sea) issue, classification bodies have imposed strict limitations on the magnitude of harmonic voltage distortion permitted on vessels classed under their rules [2]. Any vessels exceeding these voltage distortion limits (5% for ABS, BV, GL, DnV and 8% for Lloyds Register) are given sufficient time (usually

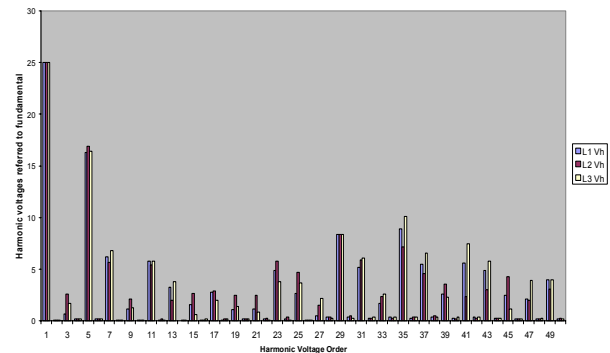

Fig. 1 Voltage harmonic spectrum of offshore oil production platform at 600V. THDv/phase was 24.1% (L1), 24.7% (L2) and 25.3% (L3). Higher THDv above 23rd was due to large number of 18-pulse and 24-pulse VFDs

3 to 6 months) to resolve the situation after which they will be removed from class if mitigation equipment has not been installed.

II. VARIABLE SPEED DRIVES AND HARMONICS

Most power systems can accommodate a certain level of harmonic current but will experience problems when the nonlinear loading becomes a significant component of the overall load. This is certainly the case in many marine applications due to the extensive use of variable speed drives or VSD's. A VSD is a solid state device that converts supply voltage to a variable voltage and frequency in order to control the speed of a 3-phase induction motor (also referred to as a variable frequency drive or VFD) or to DC for DC motor applications. By controlling the motor's speed, both energy savings and better motor control can be achieved. Typical VSD marine and offshore applications include main propulsion drives, thrusters, cables ship ROV drives, top-drives, draw-works, winches, mud pumps, compressors, general purpose fan and pump drives, etc. (Fig. 2).

VSD's generate harmonic currents because their front-end (i.e. input) rectifiers do not draw current in a sinusoidal manner. Instead they draw discontinuous, pulsed currents which can be broken down into harmonic components by applying Fourier analysis. For a typical 3-phase rectifier bridge, the predominant harmonic currents that will be generated are 5th, 7th, 11th and 13th. Typical current distortion levels range from 35% to over 80%, depending upon whether an AC or DC reactor is applied to the drive or not.

March 6, 2007.

I. C. Evans, is President of Harmonic Solutions Co. UK, Dunfermline, Fife KY11 2YN, Scotland. (email: harmonicsolutions@tiscali.co.uk).

A. H. Hoevenaars, P. Eng. is Vice President of Mirus International Inc., Mississauga, Ontario L5T 2K6 Canada. (email: hoevenaars@mirusinternational.com)

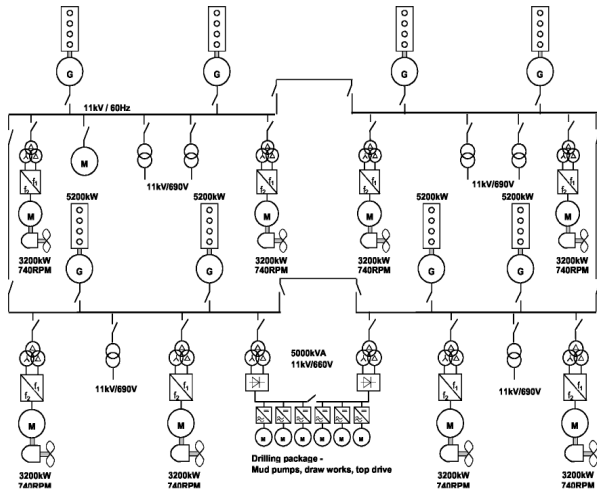

Fig. 2. Typical power system single line diagram for dynamically positioned Class 3 drilling rig.

As currents at the various harmonic frequencies flow through the power system, they create voltage distortion and excessive losses. Voltage distortion is an accumulation of the individual voltage drops that result as each harmonic current passes through the impedance of the power system. In marine applications, the relatively high source impedance of the supply generators can cause excessive levels of voltage distortion.

Problems that may result from harmonic distortion include:

- Overheating of rotating equipment, such as electric motors and generators
- High voltages and circulating currents caused by harmonic resonance
- Equipment malfunctions due to excessive voltage distortion
- Increased internal losses in connected equipment resulting in component failure and shortened lifespan
- False operation of protection equipment
- Lower system power factor preventing effective utilization of system capacity
- Voltage regulator problems on generators

Harmonics can be a particularly serious problem in Zone 1 and Zone 2 explosion proof motor installations such as those encountered on LPG carriers, oil and chemical tankers and oil production platforms. For example, an increased risk of explosion can result from the degradation of shaft seals on flameproof motors. Also, rotors that are overheated by harmonics can degrade bearing lubrication resulting in frictional sparking. In an attempt to protect against this, certifications on standard IEC explosion proof motors are conditional upon voltage distortion levels of 2% or 3% depending upon their specific protection concept [3][4][5]. The motor will lose certification as an ‘explosion proof type’ if these limits are exceeded.

The problem of harmonic voltage distortion on explosion proof motors is not without foundation. Serious consideration is being given to the possibility that the world’s largest

offshore oil field disaster in 1988, the Piper Alpha platform in the Scottish North Sea, may have been caused by harmonics on the power system due to large electrical submersible pumps and other variable speed drives. It is now suspected that fixed speed ExN motors (non sparking for Zone 2 use only) connected to a supply with high levels of voltage distortion, may have caused ignition of escaping gas or vapour. Also, a large fire on another oil platform in the North Sea occurred in March 2006 and took over four hours to extinguish. The platform is acknowledged to have high levels of voltage distortion and the fire attributed to the failure of an explosion proof motor according to official press releases.

To mitigate the harmonic current and voltage distortion introduced by VSD’s, a number of techniques are being used to varying degrees of effectiveness.

III. PHASE SHIFTING AND MULTI-PULSE DRIVE SYSTEMS

Multi-pulse drive systems have been one of the most common forms of harmonic mitigation used on marine vessels to date. In this technique, transformers with multiple secondary windings are used to phase shift multiple VSD rectifiers against each other.

A drive system’s pulse number is determined by the number of discrete converters used and the phase shift angles between these converters. The characteristic harmonics generated by the diode bridge rectifier of a VSD will follow the relationship below:

$$h = np \pm 1,$$

where: h = the harmonic number

n = any integer

p = the pulse number of the rectifier

Most VSD’s incorporate a 3-phase, 6-pulse (p = 6) diode bridge rectifier which results in currents of harmonic number 5th, 7th, 11th, 13th, etc. being generated. When dual rectifiers are used and phase shifted by 30°, a 12-pulse scheme is created. 12-pulse VSD’s will only have residual amounts of 5th and 7th harmonics as substituting p = 12 in the above equation results in harmonics 11th, 13th, 23rd, 25th, etc. Similarly, an 18-pulse drive consists of three input rectifiers and 20° phase shifts between them (Fig. 3).

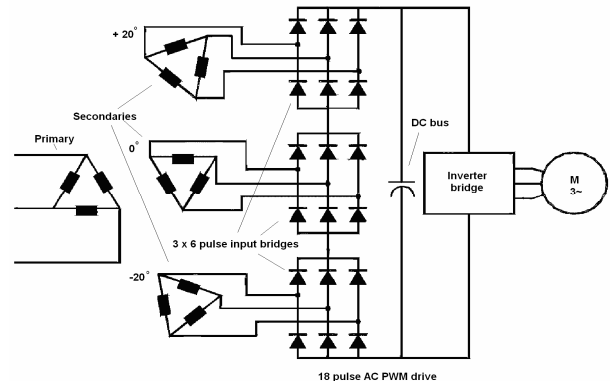

Fig. 3. Typical 18-pulse drive system. Three 6-pulse converters and three secondary windings, 20 deg displaced

Configurations up to 48-pulse are possible for very large systems but the effectiveness of phase shifting at high pulse numbers becomes questionable because the phase angles of harmonic currents at higher frequencies are typically not similar enough to produce sufficient cancellation.

Although they are theoretically an effective means of harmonic treatment, all phase shift drive systems can perform rather poorly under real world conditions. Tolerances in manufacture of the transformer windings, applied voltage imbalances, pre-existing voltage distortion and light loading levels will have a detrimental effect on the drive's ability to cancel harmonic currents at the high frequencies. Fig 4 illustrates the effect of 2% voltage imbalance on a typical 18-pulse drive system while Fig 5 shows the performance degradation when background voltage distortion is present.

It should be noted that in addition to increasing the levels of characteristic harmonics, voltage imbalance and/or excessive levels of background voltage distortion will also result in the appearance of uncharacteristic harmonics, including triplens and even order [1]. Background voltage distortion on ships and offshore oil platforms often reach levels above 10% and measurements above 20% are not uncommon as illustrated in Fig 1. Therefore, when using phase shift based drive systems, it is important to consider if an acceptable level of mitigation will be achieved under the very likely scenario of high levels of background distortion and voltage imbalance.

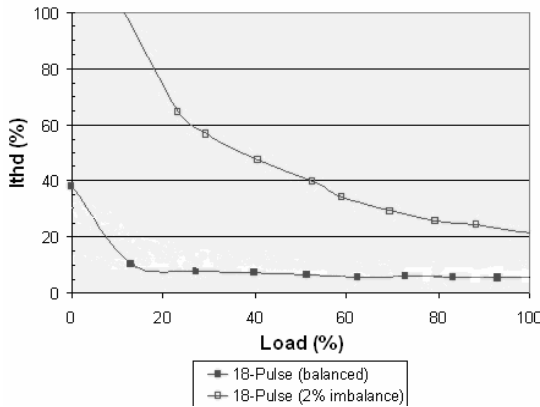

Fig. 4. Effect of 2% voltage imbalance on an 18-Pulse drive

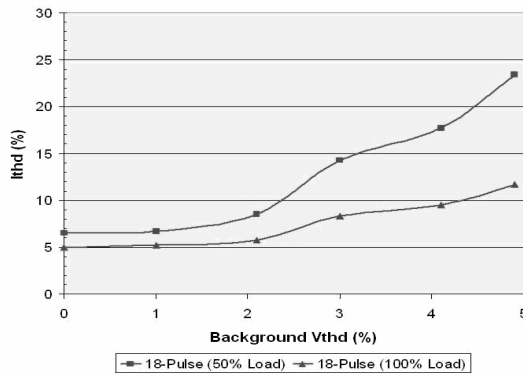

Fig. 5. Effect of background voltage distortion on an 18-Pulse drive

IV. ACTIVE FILTERS

Active filters are current injection devices and are categorized into two distinct types, ‘Selective FFT’ and ‘Broadband’. Selective FFT’s allow for selection of the harmonic orders being mitigated up to a maximum number, usually 15 or 25 harmonic orders. Broadband systems, on the other hand, can treat all the non fundamental currents, not just integer harmonics. This includes non characteristic harmonics, interharmonics and load generated disturbances. In addition, the Selective FFT responds rather slowly (40 to 50 msec) whereas Broadband systems respond at 40 to 100 usec and are more suited to dynamic loads. In this paper we will only consider the Broadband type of active filter (Fig. 6).

An active filter is connected in parallel with the loads (nonlinear and any linear loads) and monitors the load current through two current transformers (CTs) located on the load side of the active filter connection (Fig. 7). Measurements from the CTs, which include the current waveshapes, are fed into a ‘notch filter’ (i.e. band stop filter) which removes the fundamental component of current (i.e. 50Hz or 60Hz component). The remaining signal is then classed as ‘distortion current’ (i.e. all non fundamental currents). The signal is processed and used to construct a current waveform, which when added in real time to the load current waveform, results in a near sinusoidal current upstream of the filter.

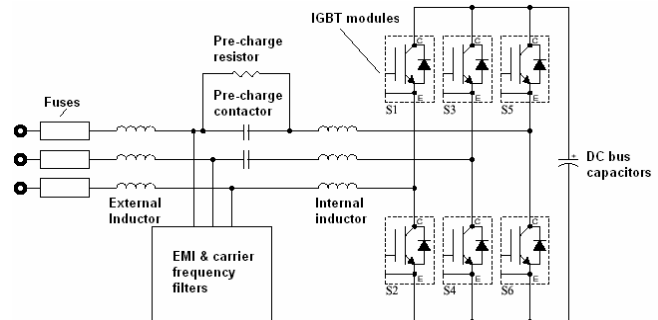

Fig. 6. Simplified power circuit of broadband active filter

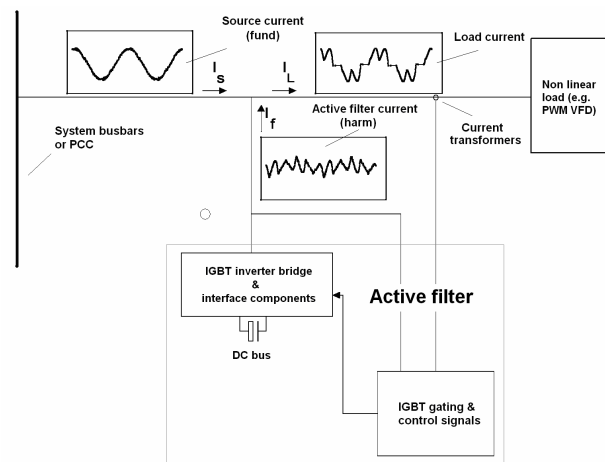

Fig. 7. Block diagram of typical shunt connected broadband active filter with associated current waveforms

If the filter's cancellation current rating is properly sized, it will produce the harmonic currents which the load requires to function and the source will only be asked to provide the fundamental current. An active filter cannot be overloaded. At 100% cancellation rating, the device will 'saturate' (i.e. current limit) and any additional harmonic currents will spill over into the source as distortion current, increasing the THDi and associated THDv on the source side.

Active filters can be expensive and are complex, utilizing technology similar to that adopted in VFD's, but if applied correctly can offer high levels of performance (i.e. < 5% THDi).

Figures 8, 9 and 10 illustrate the typical performance of a 600A broadband active filter on 3 x 800HP, 6-pulse DC drives employed on an offshore oil platform. Current distortion was reduced from 34% to 3.6% while voltage distortion was reduced from over 11% to under 4%.

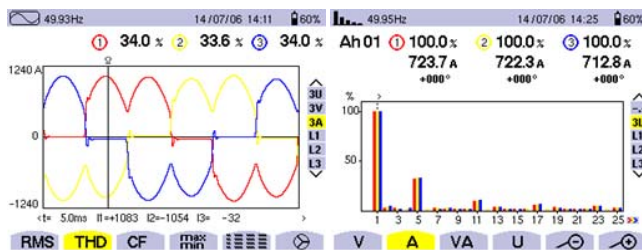

Fig. 8. Current waveform and spectrum without active filter, THDi = 34%

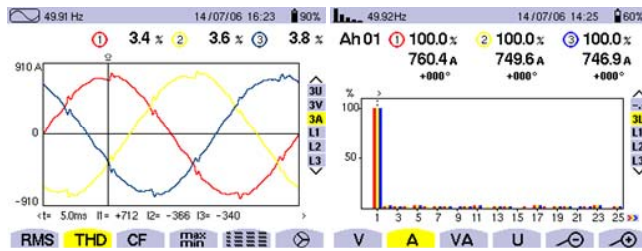

Fig. 9. Current waveform and spectrum with active filter, THDi = 3.6%

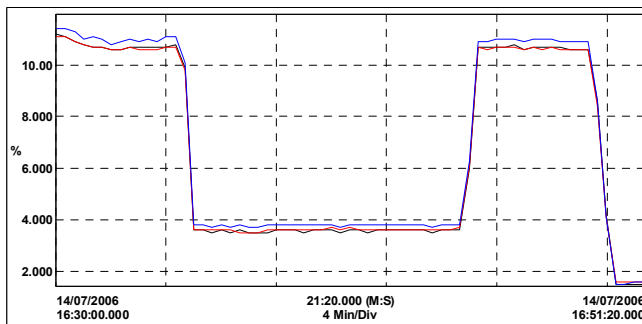

Fig. 10. THDv on 3 x 800HP DC SCR drives with/without/broadband active filters. THDv - 11.2% to 3.7% when active filter operating.

Active filter concerns include cost (purchase, spares and commissioning), complexity and reliability. Resonance conditions can exist between the carrier filters and background high frequency harmonics, if present. Also, the drives should be equipped with at least 3% AC line reactors to reduce the harmonic current they produce and, if DC Drives are present, to protect the SCR snubber components from damage due to

the carrier frequency ripple. Special low impedance transformers may be required to reach voltage levels above 480V or 600V depending upon the manufacturer.

V. ACTIVE FRONT-END DRIVES

An active front end (AFE) drive consists of an AC PWM VFD in which the standard 6-pulse diode input rectifier is replaced by a bi-directional IGBT rectifier (Fig. 11). The input rectifier synthesizes an approximate sinusoidal current but a passive L-C-L filter (including input reactance of up to 16%) is required to help reduce the harmonic current distortion and to attenuate the carrier ripple frequency (i.e. the switching frequency of the AFE rectifier which is usually between 2 to 3.5kHz).

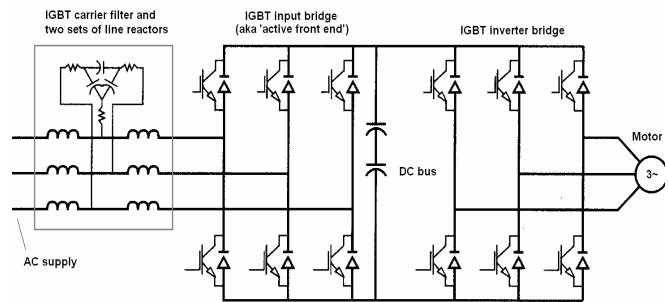

Fig. 11. AC PWM drive with IGBT active front-end

AFE drives are often promoted as the best technical solution for marine drive applications due to their low harmonic current distortion profile (typically <5% THDi). Although harmonic performance below the 50th harmonic is far superior to that produced by a standard 6-pulse VFD, there are growing concerns regarding the harmonic performance of AFE drives above the 50th harmonic which are directly attributed to the carrier switching frequency of the input IGBT rectifier. Fig 12 provides a high speed oscilloscope trace of a typical current waveform at the input terminals of an AFE drive with the high frequency components clearly visible [6].

Recent measurements taken by the Polish Register of Shipping (PRS) on a research vessel with 2 x 90kW and 2 x 315kW AFE drives used for propulsion, also show that current distortion can be > 5% even when only the harmonics up to the 50th are measured [7]. Voltage spectrum measurements above the 50th harmonic taken on the same ship show a significant increase in voltage distortion occurring near the 67th harmonic

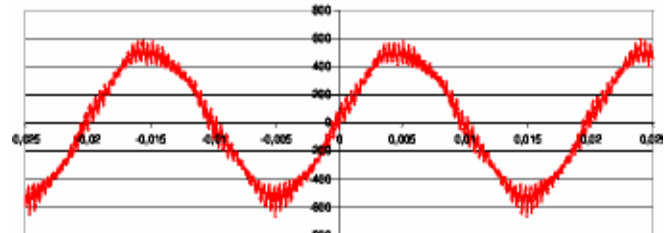

Fig. 12. AFE drive typical input current waveform [6]

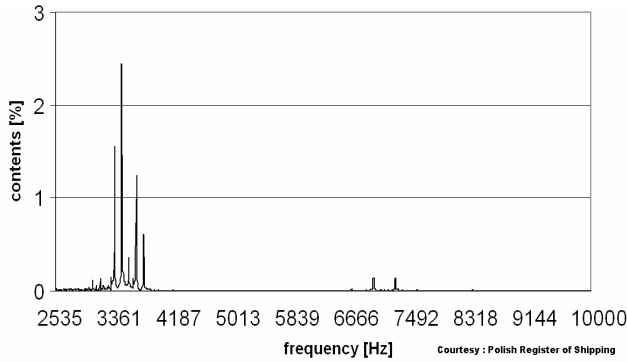

Fig. 13. Vessel with 2 x 315kW and 2 x 90kW AFE aft and forward propulsion drives. The THDv attributed to voltage harmonics above 50th (i.e. 3kHz) is ~ 3.26%. Below the 50th harmonic the THDv was 3.23%. Total THDv was 4.65% [7]

(Fig. 13). This would be the result of excessive current harmonics drawn by the AFE drives near their carrier frequency. The THDv at harmonics below the 50th was 3.32% and above the 50th was 3.25%. The total THDv (< 100th harmonic) therefore, was 4.65%. It is not surprising that some marine classification bodies, including the American Bureau of Shipping and the Polish Register of Shipping, now stipulate in their respective rules that “On vessels with active front end drives, the harmonics up to the 100th shall be measured.” [2]

There are other issues associated with AFE drives which must be addressed in order to ensure a problem free installation:

1. The EMI (electromagnetic interference) emissions, both conducted and radiated, emanating from AFE drives are almost double that from a standard 6-pulse VFD with diode or SCR pre-charge rectifier. A vessel’s power distribution system is usually based on IT networks (i.e. isolated neutral) where the vessel’s cabling provides a high frequency conducted emissions path to ground. These high frequency emissions, which circulate throughout the power system, can seriously disrupt sensitive equipment. Standard EMC filters cannot be applied in IT networks as the filter would be damaged in the event of ground faults.
2. The capacitors in the L-C-L filter used to attenuate the ripple associated with the switching of the AFE IGBT rectifier may cause resonance with the network. This may require adjustment of the filter’s capacitors to resolve, likely reducing its filtering effectiveness.
3. One advantage of an AFE drive is its ability to regenerate power (i.e. they are full four quadrant drives). While this may be applicable to cranes, hoists, etc. it is of no benefit to pumps, fans and other single quadrant applications. For main propulsion applications, the regenerative capability may be of limited value, depending upon the ability of the generators to accept the regenerated power without tripping. The British Royal Navy recently decided against AFE drives for their new Type 45 destroyers, which have 2 x 20MW, 4.16kV, 15 phase, multi-level PWM drives with 6-pulse SCR rectifiers and dynamic braking, after considering the damage to the gas

turbine generators that could result from excessive regeneration from the AFE drives during crash stop and other violent maneuvers.

4. On systems where AFE drives and standard 6-pulse VFDs have been applied to the same bus, there may be problems due to the AFE rectifier’s high frequency currents being impressed on the DC bus of the standard 6-pulse VFDs [5]. Recent studies have suggested that the 6-pulse DC bus voltage can rise by up to 15%. If the 6-pulse converter is running at light loads it may run the risk of tripping out on ‘over-voltage DC bus’.
5. On marine applications, reliability is paramount, especially on equipment for propulsion where the ability to ‘get me home’ is crucial. As a much more complex device, an AFE drive is arguably less reliable than a standard 6-pulse drive. Also, if the IGBT rectifier being used to reduce harmonics were to fail, the entire drive would be out of service. A failure of the phase shift transformers on multi-pulse drive systems would also cause these drives to shutdown. But with input filters, such as the wide spectrum filter presented next, the device may simply be by-passed in the event of failure, allowing the drive to operate. Harmonics would be generated but the drive would likely be capable of operating at a reduced output without problems.

VI. WIDE SPECTRUM PASSIVE FILTER

The wide spectrum filter consists of a reactor with multiple windings on a common core and a relatively small capacitor bank. This design, exploits the mutual coupling between the windings to improve performance. Fig 14 shows a configuration of this filter. A ‘high impedance winding’, L1, is used as the main blocking inductance and is sized to prevent the importation of upstream harmonics. A ‘filtering winding’, L3, combines with the capacitor bank to provide a low impedance path to filter out the harmonic currents generated by the downstream load. To decrease through impedance and reduce voltage drop across the filter, a ‘compensating winding’, L2, can be used and is wound in opposite polarity to the blocking winding.

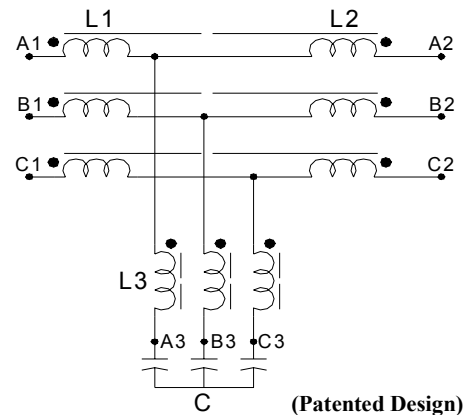

Fig. 14. Lineator™ wide spectrum harmonic filter schematic

One key advantage of the unique reactor design of the wide spectrum filter is that it allows for the use of a significantly smaller capacitor bank (typically < 18% reactive power). This will reduce voltage boost and reactive power at no load to ensure compatibility with generators. Capacitors present a source of reactive current (i.e. leading power factor) to the generator(s) which will tend to boost the generator voltage. Generators are designed to adjust for voltage drop as their load increases and typically have minimal ability to lower voltage when raised by a leading power factor load. It is therefore important that any filtering device which incorporates capacitors is designed to ensure that the filter's maximum capacitive reactive current (which occurs under no load conditions) is comfortably below the maximum allowed by the generator.

The filter is connected in series between the mains supply and the drive. THDi is typically reduced to < 6% when applied to a 6-pulse AC PWM drive (Fig. 15) regardless of whether the drive is equipped with an AC or DC reactor or not.

Wide spectrum filters can be applied to AC drives with diode or SCR pre-charge input rectifiers ranging in size from 5HP/4kW to 3500HP/2600kW at present. They can be applied to single or multiple drives but only drive loads should be connected as the filter is designed specifically for rectifier operation. The filter can usually be retrofitted to existing drives without the requirement for drive modifications, whether for single drive or for multiple drive applications.

The filter can also operate on fully controlled SCR bridges as used in DC Drives but with a slight reduction in performance.

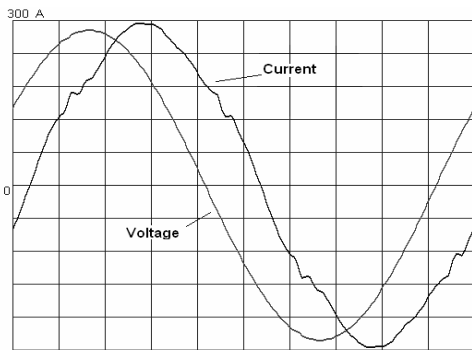

Fig. 15. Input waveforms with wide spectrum filter, THDi = 4.8%

VII. CASE STUDY – CABLESHIP APPLICATION OF LINEATOR™ WIDE SPECTRUM FILTER

Harmonic distortion resulting from the operation of numerous AC VFD's on a Norwegian cable laying vessel known as the Ocean Challenger (Fig 16), was preventing the ship from sailing without rented generators. When connected to the ship's main electrical distribution, voltage distortion significantly exceeded the 5% level permitted by the Norwegian classification body, Det Norske Veritas (DnV). By supplying all harmonic generating VSD's from the rented

generators, the voltage distortion created was isolated from the rest of the equipment on the ship. The ship's operators wanted to reduce costs and free up deck space by finding a cost effective solution for treating the VSD harmonics so that the drives could be returned to the ship's main distribution supply and the rented generators could be eliminated.

The Ocean Challenger's trenching operation is performed by a Remotely Operated Pipe-line Trenching Vehicle or ROV (Fig. 17). The ROV is equipped with ten 30kW electric thrusters for maneuvering and four 300kW Jet Sword high volume flow rate electric pumps.

The electric thrusters and pumps are independently speed controlled via AC PWM VSD's mounted in the surface module. Each VSD was equipped with a 3% AC line reactor to partially attenuate the harmonic currents they generate. When connected to the ship's normal power supply however, the 1.5MW of AC drives produced high harmonic voltage distortion on the two 2800kVA shaft generators preventing operation in this mode.

The ship's operator, CTC Marine Projects, installed 2 x 750kW Lineator™ AUHF wide spectrum filters - one for each of two groups of 5 x 30kW thrusters and 2 x 300kW pump drives. Each 750kW Lineator™ (Fig. 18) was connected to one of the 2880kVA main power shaft generators.



Fig. 16. Ocean Challenger cableship



Fig. 17. Remotely operated pipeline trenching vehicle with 10 x 30kW thrusters and 4 x 300kW pumps

In sea trials, the ‘total harmonic current distortion’ (THDi) measured at the terminals of the Lineator™ under the ROV’s maximum loading of about 85% was 6.1% and 6.4% for the Port and Starboard Lineators™ respectively (Fig. 19). It should be noted that if the VSD’s could have been run up to their full rated load, the THDi would have approached levels of < 5%.

The ‘total harmonic voltage distortion’ (THDv) at the Lineator™ terminals was measured at 2.2% and 2.7% (Fig. 20) at the 85% loading. Ship staff monitored both the operation of the two shaft generators and the THDv on the main switchboards. The ship’s electrical engineer reported that the generators operated flawlessly and at no time did the THDv rise above 1.4% and 1.6% on their respective switchboards. Fig. 18 shows the display from a Fluke 43 measured at the switchboard connected to the Port Lineator™.



Fig. 18. One of two 750kW Lineator™ units installed on each group of 750kW combined thruster and pump load

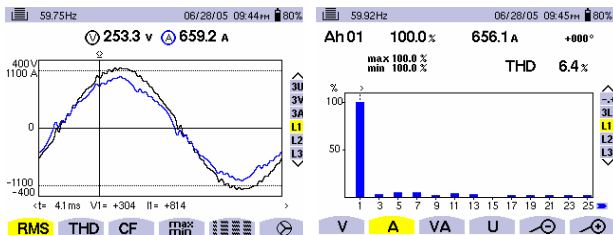

Fig. 19. Starboard Lineator™ current and voltage waveforms and current spectrum, THDi = 6.4%

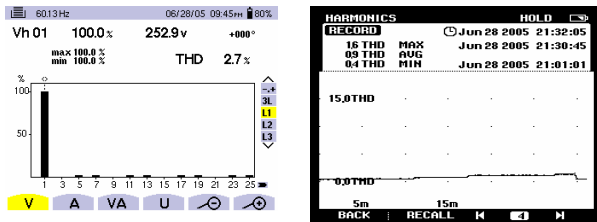

Fig. 20. Voltage spectrum at Starboard Lineator™ (THDv = 2.7%) and Port side generator voltage distortion (highest THDv = 1.6%)

The installation of the two 750kW Lineators™ allowed the vessel to meet the 5% voltage distortion limit of the DnV without the need for the rented generators and additional deck space. Two years later, CTC Marine Projects were pleased to report that the Lineators™ have worked fully to specification without any incident, cost-effectively resolving the high voltage distortion issue.

VIII. CONCLUSION

As the marine industry has moved towards electric propulsion and other uses for variable speed drives, harmonics have become a major power quality concern. This has led classification bodies to demand that voltage distortion remain below acceptable levels. A few of the technologies being adopted to mitigate the effects of harmonics have been reviewed and a case study was presented where a unique passive, wide spectrum filter was successfully installed on a cable laying ship to meet the limits required by one of these classification bodies, DnV.

REFERENCES

- [1] S. Bourguet, P. Guerin, R. Le Doeuff, *Non-characteristic harmonics generated by frequency converter*, GE44, Laboratory, Saint-Nazaire, France, All Electric Ship 2003, Edinbough.
- [2] *ABS Guidance Notes on Control of Harmonics in Electrical Power Systems*, May 2006, American Bureau of Shipping
- [3] IEC 60034-1, *Rotating electrical machines – Part 1: Rating and performance*, 2004-04, International Electrotechnical Commission
- [4] IEC 60034-12, *Rotating electrical machines – Part 12: Starting performance of single-speed three-phase cage induction motors*, 2002-04, International Electrotechnical Commission
- [5] I. C. Evans, *Are we Playing with Fire*, Electrical Review (UK), Vol. 221.No 3. Feb 1988. Page 32
- [6] L. Moran, J. Espinoza, M. Ortiz, J. Rodrique, J. Dixon, *Practical Problems Associated with the Operation of ASDs Based on Active Front End Converters in Power Distribution Systems*, Industrial Applications Conference, 2004, Vol. 4, 3-7 Oct. 2004, pp 2568-2572
- [7] J Mindykowski, T Tarasiuk, M Szweda and I C Evans, “*Electric Power Quality Measurements on an All Electric Ship with Active Front End Propulsion Drives*”, Polish Register of Shipping, Gdynia Maritime University. Due for publication May-June 2007



SCIGATE AUTOMATION (S) PTE LTD
 No.1 Bukit Batok Street 22 #01-01 Singapore 659592
 Tel: (65) 6561 0488 Fax: (65) 6562 0588
 Email: sales@scigate.com.sg Web: www.scigate.com.sg
 Business Hours: Monday - Friday 8.30am - 6.15pm