

EchoPod® UG01 & UG03

Reflective Ultrasonic Multi-Function Liquid Level Transmitter



Application

The general purpose reflective ultrasonic multi-function level transmitter provides continuous level measurement up to 9.8' (3m) with a 4-20 mA analog signal output and four relays, and is configured via our WebCal software. The non-contact liquid level sensor features our proprietary Reflective Technology™ that delivers reliable level measurement in condensing environments. Each relay can be configured for alarm, automatic fill or empty functions. Select this sensor for small tanks with non-foaming or highly vaporous media such as chemicals, water, wastewater and oil. Typical applications include day tank, IBC or drum, cooling tower, skid or machine, process tank and waste sumps.



Features

- Offered in 1.5m (4.9') and 3m (9.8') measurement ranges
- Fail-safe diagnostics with selectable relay and signal outputs
- Narrow 2" (5cm) beam width for applications with limited space
- Corrosion resistant PVDF transducer and compact PP enclosure
- Short 1.5" (3.8cm) dead band maximizes tank filling capacity
- Automatic temperature compensation from -40° to 80° C.
- Four programmable relays with embedded level control logic
 - 1 pump or valve with 3 alarms
 - 2 pumps duplexing with 2 alarms
 - 2 pumps lead-lag with 2 alarms
 - 4 independent switch point alarms



Reflective Technology™

Condensation is the most common variable in liquid level applications. Condensation attenuates the acoustic signal of ultrasonic sensors with horizontal transducers, weakening their signal strength and signal to noise ratio by up to 50%, and substantially reducing their measurement reliability. At the core of Reflective Technology™ is a simple fact. Unlike flat horizontal surfaces, significant water droplets cannot adhere to smooth vertical surfaces. By orienting the transducer vertically, condensation runs off the transducer and does not affect sensor performance. The unimpeded transmit and receive signals are redirected to and from the liquid off a 45° reflector, delivering reliable level measurement. Thanks gravity.

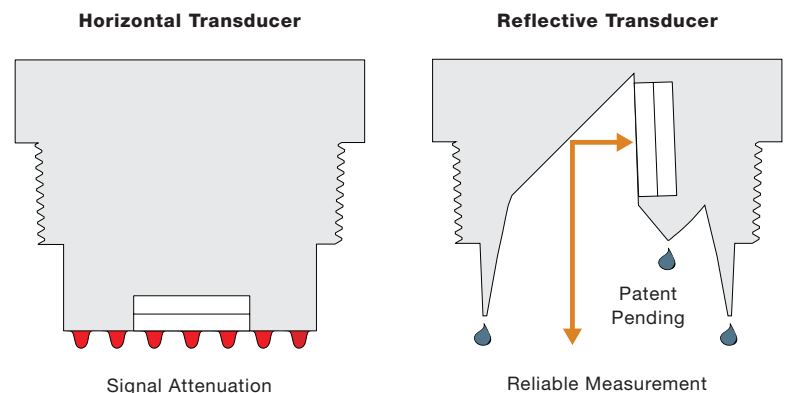



EchoPod® UG01 & UG03

Reflective Ultrasonic Multi-Function Liquid Level Transmitter

SCIGATE AUTOMATION (S) PTE LTD

No.1 Bukit Batok Street 22 #01-01 Singapore 659592
 Tel: (65) 6561 0488 Fax: (65) 6562 0588
 Email: sales@scigate.com.sg Web: www.scigate.com.sg
 Business Hours: Monday - Friday 8.30am - 6.15pm

Specifications

Range:	UG01: 1.5" to 4.9' (3.8cm to 1.5m) UG03: 4" to 9.8' (10.1cm to 3m)
Accuracy:	UG01: 0.125" (3mm) UG03: ± 0.2% of range
Resolution:	UG01: 0.019" (0.5mm) UG03: 0.039" (1mm)
Dead band:	UG01: 1.5" (3.8cm) UG03: 4" (10.1cm)
Beam width:	2" (5cm)
Configuration:	WebCal® PC Windows® USB® 2.0
Memory:	Non-volatile
Supply voltage:	14-28 VDC
Max.consumption:	0.5W
Loop resistance:	500 ohms @ 24 VDC
Signal output:	4-20mA, two-wire
Signal invert:	4-20mA or 20-4mA
Signal fail-safe:	4mA, 20mA, 21mA, 22mA, hold last
Contact type:	(4) SPST relays
Contact rating:	60 VA, 1A maximum
Contact fail-safe:	Open, closed, hold last
Contact hysteresis:	Selectable
Process temp.:	F: -40° to 176° C: -40° to 80°
Temp. comp.:	Automatic
Ambient temp.:	F: -31° to 140° C: -35° to 60°
Pressure:	30 psi (2 bar)
Enclosure rating:	Type 6P (IP68)
Encl. material:	Polypropylene
Transducer type:	Reflective
Transducer mat.:	Polyvinylidene fluoride
Cable jacket mat.:	Polyurethane
Cable type:	9-conductor, shielded
Cable length:	48" (1.2m)
Process mount:	-0001: 2" NPT -0011: 2" G
Mount gasket:	-0001: N/a -0011: Viton®
Classification:	General purpose
Approval (pending):	UL 61010-1
Compliance:	CE, RoHS

Dimensions

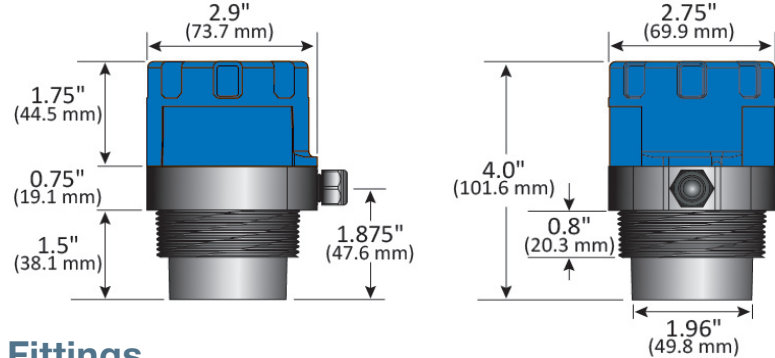

Fittings



TANK ADAPTERS

- LM52-2890** 2" NPT bulkhead fitting, PVC
- LM52-3890** 3" NPT bulkhead fitting, PVC

REDUCER BUSHINGS

- LM52-2400** 3" thread x 2" thread, NPT, PVC, schedule 40
- LM52-2410** 3" socket x 2" thread, NPT, PVC, schedule 40
- LM52-2800** 3" thread x 2" thread, NPT, PVC, schedule 80
- LM52-2810** 3" socket x 2" thread, NPT, PVC, schedule 80
- LM52-3800** 4" thread x 2" thread, NPT, PVC, schedule 80
- LM52-3810** 4" socket x 2" thread, NPT, PVC, schedule 80

BRACKETS

- LM50-1001** 2" NPT side mount bracket, PP
- LM50-1061** 2" G side mount bracket, PP

Configuration

The sensor is configured via our WebCal software and one Fob USB adapter. WebCal is a PC utility program that allows users to easily configure their sensors, update firmware, save configurations and print wiring schematics prior to installation. WebCal is a free download from our website.



Ordering

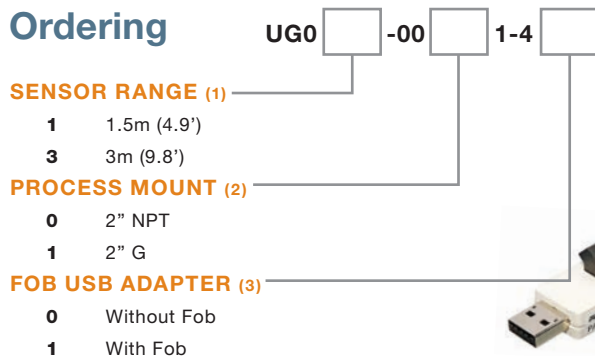

NOTES

- 1) If you want help in selecting a sensor for your application, please go to our website and submit a Level Questionnaire. An engineer will review your requirements and suggest a product solution via email.
- 2) Install the sensor using Flowline installation fittings or equivalents.
- 3) The sensor is configured via our WebCal software and one LI99-2001 Fob USB adapter. Sensors are offered with or without a Fob. Fobs are universal and can be used to configure any WebCal compatible ultrasonic or guided wave sensor. WebCal is a free download from our website.