

# EchoPod®

Ultrasonic Level Transmitter



## UG01 & UG03 Series Manual



### SCIGATE AUTOMATION (S) PTE LTD

No.1 Bukit Batok Street 22 #01-01 Singapore 659592

Tel: (65) 6561 0488

Fax: (65) 6562 0588

Email: sales@scigate.com.sg

Web: www.scigate.com.sg

Business Hours: Monday - Friday 8.30am - 6.15pm



An ultrasonic sound wave is pulsed from the base of the transducer. The sound wave reflects against the process medium below it. The sound wave energy is returned to the transducer. The microprocessor based electronics measures the time of flight between the sound pulse generation and its receipt. This translates into the distance or range between the transducer and process media below.

**NEW FEATURES**

- Reflective Ultrasonic Technology
- Simple configuration with WebCal<sup>®</sup> software configuration
- Increased temperature range
- Increased output filtering

**TABLE OF CONTENTS**

Introduction: ..... 2

Specifications: ..... 4

Dimensions: ..... 5

About this manual: ..... 6

Getting Started: ..... 7

Setup Overview: ..... 7

Reflective Technology: ..... 7

Components: ..... 8

Basic Configuration: ..... 9

Basic Relay Settings: ..... 9

Understanding Sensor Height: ..... 10

Understanding Fill-Height: ..... 11-12

Sensor Output to Local Display: ..... 13

Configuration: ..... 14

Configuring EchoPod<sup>®</sup> with WebCal: ..... 14

Step 1 – Install WebCal Software: ..... 15

WebCal System Requirements: ..... 15

USB<sup>®</sup> Fob (LI99-2001) Interface: ..... 16

Step 2 – Measure the Tank: ..... 17

Step 3 – Sensor Configuration: ..... 18

Step 4 – Dimensional Entry: ..... 19

Step 5 – Tank Level Confirmation: ..... 20

Step 6 – Write to Unit: ..... 20

Installation: ..... 21

Mounting Guide: ..... 21

Fitting Selection: ..... 22-24

---

Wiring: .....25

- Wiring Diagram – Sample: .....25
- Wiring EchoPod® .....25
- Wire Connections:.....26
- General Notes for Electrical Connections, Usage and Safety: .....26
- Common Wiring to Displays, Controllers & PLCs: .....27-28
- Switching Inductive Loads: .....29
- Voltage Output: .....29

WebCal® Appendix: .....30

- Sensor Configuration: .....30-36
  - Number of Pumps: .....30
  - Pump/Valve Action:.....31
  - Pump/Valve Mode: .....32
  - Relay Fail-Safe:.....33
  - Switch/Alarm Configuration: .....34
  - Switch Hysteresis/Dead Band: .....35
  - Loop Fail-Safe: .....36
  - Output at Empty: .....36
- Volumetric Configuration:.....37-39
- Tank Level Confirmation: .....40
- Write to Unit” .....41

Appendix:.....42

- Factory Settings: .....42
- User Settings: .....42
- Troubleshooting: .....43

Warranty: .....44

## SPECIFICATIONS

**Electrical:**

Supply Voltage:	14-28 Vdc
Signal output:	4 to 20 mA current loop; 22 mA max.
Signal invert:	4-20mA or 20-4mA
Signal fail-safe:	4mA, 20mA, 21mA, 22mA or hold last value
Loop resistance:	500 Ohms @ 24 VDC
Contact type:	(4) SPST relays, 1A
Contact fail-safe:	Power loss: Hold last Power on: Open, close or hold last
Hysteresis:	Selectable

**Mechanical:**

Enclosure:	Polypropylene (PP-FR GF30)
Transducer:	Polyvinylidene Fluoride (PVDF)
Cable jacket mat'l:	Polyurethane
Cable type:	9-conductor
Cable length:	4' (121.9 cm)
Process Mount:	2" NPT or 2" G
Gasket	Viton A (G thread only)
Classification:	General purpose
Compliance:	CE, RoHS

**Environmental:**

Process temperature:	F: -40° to 176° C: -40° to 80°
Temp. compensation:	Automatic
Ambient temp.:	F: -31° to 140° C: -35° to 60°
Pressure:	30 psi, derated @ 1.667 psi per degree C above 25 °C
Enclosure:	IP68, NEMA 6P

**Functional:**

Range:	UG01: 1.5m (4.92 feet) UG03: 3.0m (9.84 feet)
Dead band:	UG01: 3.8cm (1.5 inches) UG03: 10m (4 inches)
Accuracy:	UG01: 0.125" (3mm) UG03: 0.2% of Range in air at 20 °C
Resolution:	0.125" (3mm)
Beam width:	2" (5cm)
Configuration:	WebCal® configuration software
Memory:	Non-volatile

**DIMENSIONS**

**Dimensions for UG01 & UG03 Series**

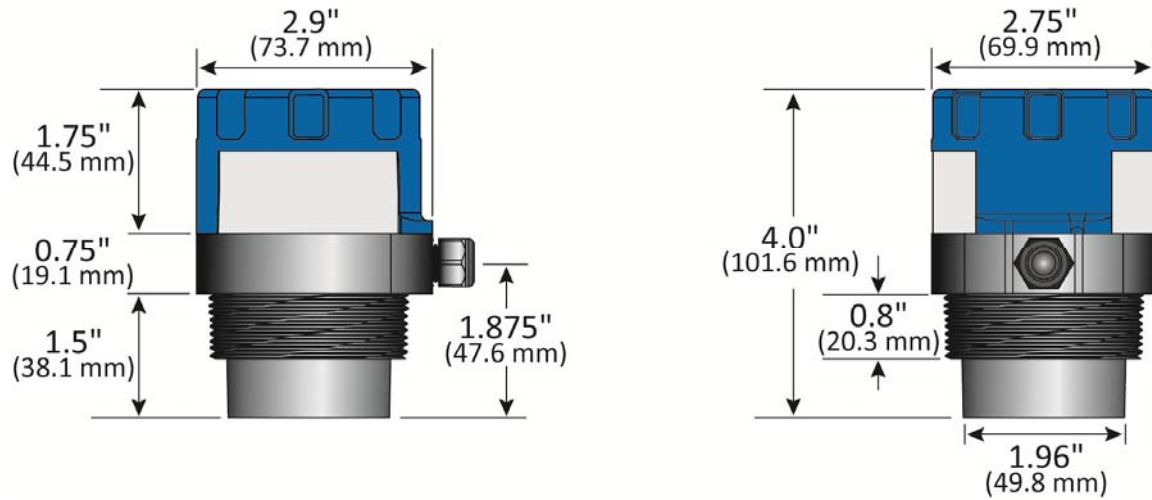

**Cable Dimensions for UG01 & UG03 Series**

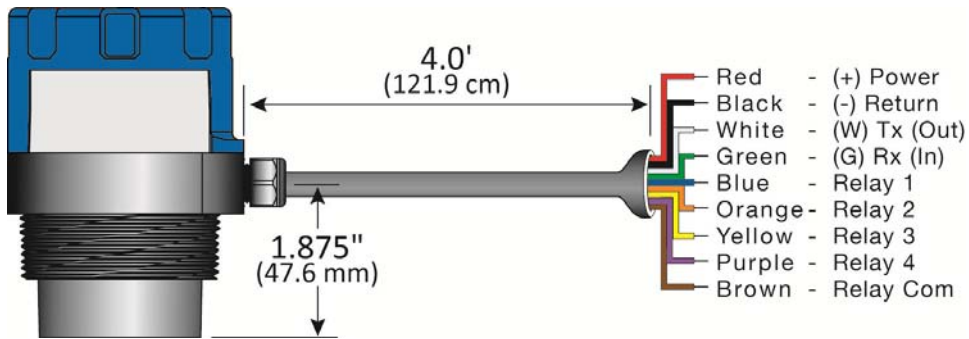

**⚠ About this Manual:** PLEASE READ THE ENTIRE MANUAL PRIOR TO INSTALLING OR USING THIS PRODUCT. This manual includes information on the EchoPod® series Ultrasonic Level Transmitter from FLOWLINE. Please refer to the part number located on the sensor label to verify the exact model configuration, which you have purchased.

**⚠ User's Responsibility for Safety:** FLOWLINE manufactures a broad range of level sensing technologies. While each of these sensors is designed to operate in a wide variety of applications, it is the user's responsibility to select a sensor model that is appropriate for the application, install it properly, perform tests of the installed system, and maintain all components. The failure to do so could result in property damage or serious injury.

**⚠ Proper Installation and Handling:** Only professional staff should install and/or repair this product. Never over tighten the sensor within the fitting. Always check for leaks prior to system start-up.

**⚠ Wiring and Electrical:** A supply voltage of 14 to 28 VDC is used to power the EchoPod®. Electrical wiring of the transmitter should be performed in accordance with all applicable national, state, and local codes.

**⚠ Material Compatibility:** The enclosure is made of Polypropylene (PP-FR GF30). The transducer is made of Polyvinylidene Fluoride (PVDF). Make sure that the model, which you have selected, is chemically compatible with the application media.

**⚠ Enclosure:** While the sensor housing is liquid-resistant the EchoPod® is not designed to be operational when immersed. It should be mounted in such a way that the enclosure and transducer do not come into contact with the application media under normal operational conditions.

**⚠ Handling Static-Sensitive Circuits/Devices:** When handling the transmitter, the technician should follow these guidelines to reduce any possible electrostatic charge build-up on the technician's body and the electronic part.

1. Always touch a known good ground source before handling the part. This should be repeated while handling the part and more frequently after sitting down from a standing position, sliding across the seat or walking a distance.
2. Avoid touching electrical terminals of the part unless making connections.

**⚠ Make a Fail-Safe System:** Design a fail-safe system that accommodates the possibility of switch and/or power failure. FLOWLINE recommends the use of redundant backup systems and alarms in addition to the primary system.

**Flammable, Explosive or Hazardous Applications:**  
*EchoPod® should not be used within classified hazardous environments.*

**⚠ Warning:** Always use the Viton® gasket when installing the "G" threaded version of EchoPod®.

**⚠ Warning:** Make sure that all electrical wiring of the switch is in accordance with applicable NEC codes.

**SETUP OVERVIEW**

Below highlights the initial steps in setting up your sensor for operation.

1. **Check Part Number** (Section Two)
  - a. Confirm that the sensor's part number matches the ordered part number and all components are provided with the model delivered.
2. **Measurements, Installation & Software** (Section Two)
  - a. Understand the location placement of the sensor relative to Measurement Range including Sensor Height and Fill-Height settings.
  - b. Download the WebCal<sup>®</sup> software from [www.flowline.com/webcal-software/](http://www.flowline.com/webcal-software/).
3. **Configure Sensor with WebCal<sup>®</sup>** (Section Three)
  - a. Section 3 contains information on using the WebCal<sup>®</sup> configuration software.
4. **Install the sensor** (Section Four)
  - a. Section 4 contains information about the sensor location placement and its mechanical installation.
5. **Wire the sensor** (Section Five)
  - a. Section 5 contains information about the sensor's electrical wiring and power requirements.

**REFLECTIVE TECHNOLOGY**

Condensation is the most common variable in liquid level applications. Condensation attenuates the acoustic signal of ultrasonic sensors with horizontal transducers, weakening their signal strength and signal to noise ratio by up to 50%, and substantially reducing their measurement reliability. At the core of Reflective Technology™ is a simple fact. Unlike flat horizontal surfaces, significant water droplets cannot adhere to smooth vertical surfaces. By orienting the transducer vertically, condensation runs off the transducer and does not affect sensor performance. The unimpeded transmit and receive signals are redirected to and from the liquid off a 45° reflector, delivering reliable level measurement.

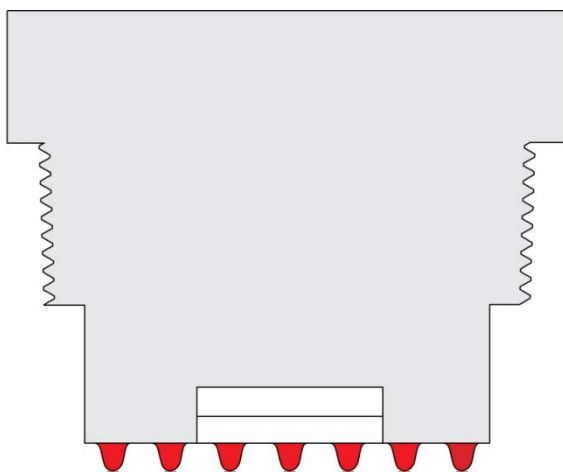
**FLAT TRANSDUCER**

Signal Attenuation

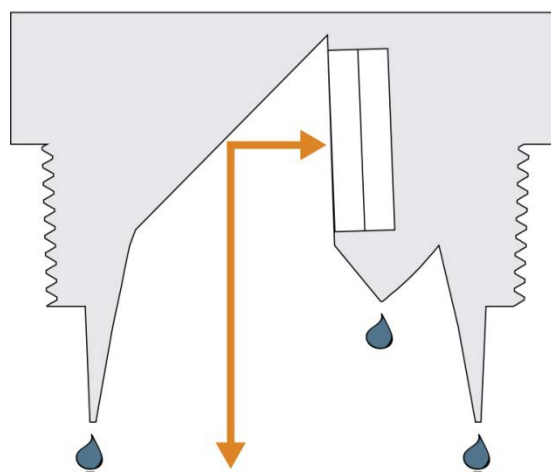
**REFLECTIVE TRANSDUCER**

Reliable Measurement

**COMPONENTS**

EchoPod® is offered in two different models with 4-20 mA output and relay control. Depending on the model purchased, you may or may not have been shipped all the components shown below. All G threaded process mounts require a Viton® gasket for installation and operation of EchoPod®.

P/N	Max. Range	Dead Band	Thread	Fob	Output	Configuration
UG03-0001-40	9.8' (3m)	8" (20cm)	2" NPT	Not Included	4-20mA & 4 SPST Relays	WebCal® only
UG03-0001-41				Included		
UG03-0011-40			2" G	Not Included		
UG03-0011-41				Included		
UG01-0001-40	4.9' (1.5m)	4" (10cm)	2" NPT	Not Included		
UG01-0001-41				Included		
UG01-0011-40			2" G	Not Included		
UG01-0011-41				Included		

- Viton® Gasket (G threaded version only)
  - Part #210138
- Fob (UG0\_-00\_1-41 series only)
  - Part #LI99-2001
- Quick Start Guide



**BASIC CONFIGURATION**

EchoPod® can be configured using the Flowline™ on-line free WebCal® software download coupled to a USB® port with a USB® Fob.

EchoPod® can be configured before installation or after installation. The transmitter features non-volatile memory, so any settings configured before installation will not be lost when the sensor is powered down. To start, the following information is required:

- Basic Tank Information
  - **HEIGHT** (Sensor Height) – Distance from the bottom of the tank to the bottom of the sensor.
  - **FILL-H** (Fill-Height) – Maximum fill height of the liquid from the bottom of the tank.
- Power:
  - Provide input power to the EchoPod®

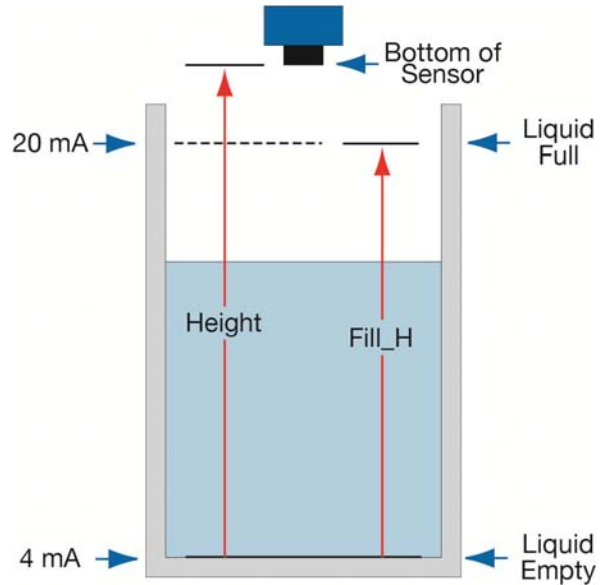

**Note:** The **HEIGHT** and Fill-Height (**FILL-H**) settings also determine the 4 to 20 mA current span. The **HEIGHT** setting determines the 4mA position and the **FILL-H** setting determines the 20 mA position.

**BASIC RELAY SETTINGS**

- **High Alarms (Hi)** – Used to energize a relay (ON) when the level reaches the Hi setting. Relay will de-energize (OFF) when level falls below the original setting.
- **Tank Fill (ON & OFF)** – Used to automatically fill a tank using only one relay. Relay energize at ON level and remains energized until it reaches the OFF level where it de-energizes. Relay remains de-energized until the level falls below ON level.
- **Tank Empty (not shown)** – is the exact opposite of Tank Fill. One relay is used to empty the tank with ON set to a high point in the tank and OFF set to a low point.
- **Lo Alarms (Lo)** – Used to energize a relay (ON) when the level falls below the Lo setting. Relay will de-energize (OFF) when level rises above the original setting.

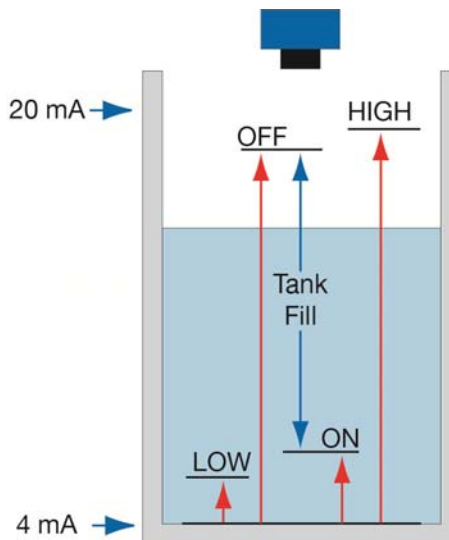

**Note:** All relay settings are referenced from the Empty or 4mA setting of the tank.

**UNDERSTANDING SENSOR HEIGHT**

This is a critical setting for EchoPod®. Sensor Height (SH) defines the location of the sensor from the bottom of the tank. The value must take into account the shape of the tank and any risers, fittings, structures or extensions associated with the tank or the installation (see examples below). The reference point for definition of the Sensor Height is always the bottom of the mounting nut.

**Simple Vertical Tank**

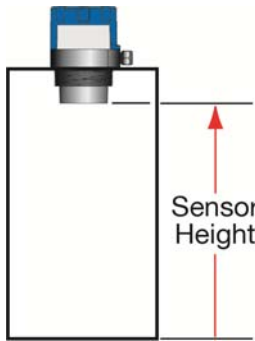

**Dome Top Raises HEIGHT**

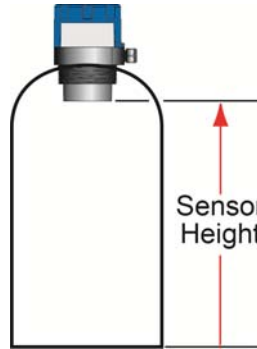

**Sensor Off-center Changes HEIGHT**

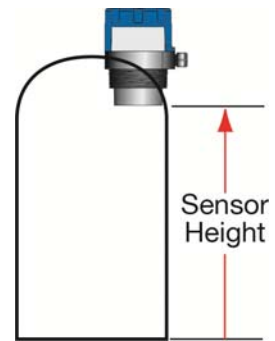

**Simple Open Top Tank**

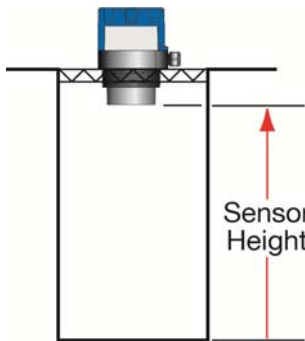

**Sensor Extends into Sump**

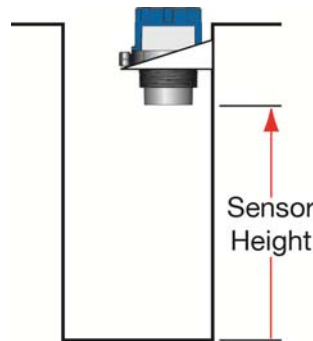

**Cone Bottom Elevates HEIGHT**

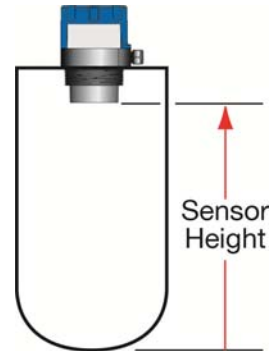

**Simple Horizontal Tank**

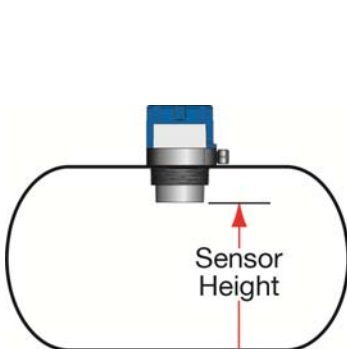

**Riser Elevates HEIGHT**

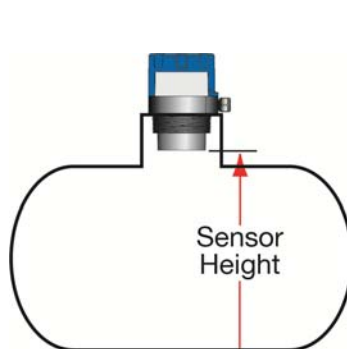

**Mounting Fixture Elevates HEIGHT**

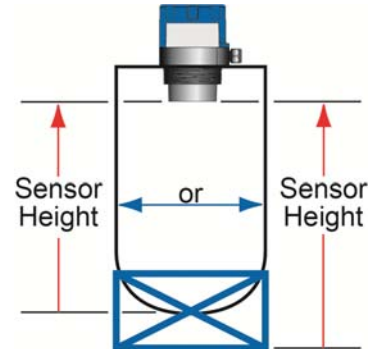

**UNDERSTANDING FILL-HEIGHT**

This is another critical setting for EchoPod®. Fill-Height defines the location of the highest point in the tank where the sensor will read level changes. When the level rises above Fill-Height, the sensor will read full (as long as the level does not enter the dead band). The reference point for definition of Fill-Height is always from the bottom location of the Sensor Height. The value must take into account the sensors dead band, any risers, fittings, structures or extensions associated with the tank or the installation as well as the tanks geometry.

**Example #1 – Flat Top Tanks**

**Tank A** is a vertical tank with a flat top. The highest value for Fill-Height can be calculated by subtracting the Dead Band from the Sensor Height.

$$\text{Fill-Height} = \text{Sensor Height} - \text{Dead Band}$$

**Tank B** is another vertical tank with a riser that matches the dead band of the sensor. In this case, the Fill-Height will be set to the top of the tank.

**Note:** The ratio of height to diameter of the riser must be no greater than 2:1. Any higher and the sensor will target the inside wall of the riser.

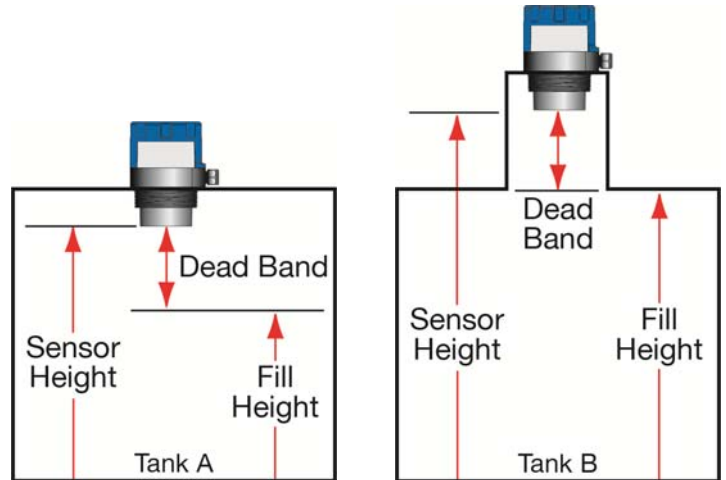

**Example #2 – Dome Top Tanks**

**Tank C** has a tall enough dome whereas the Dead Band is above the straight side of the tank. The Fill-Height can be set to the top of the straight side (this is advantageous because the top of the straight side is typically a known volume of liquid).

The sensor is moved to a flat part of **Tank D**. As a result, the Dead Band is now below the straight side of the tank. Fill-Height cannot be set to match the straight side of the tank. Calculate Fill-Height as follows:

$$\text{Fill-Height} = \text{Sensor Height} - \text{Dead Band}$$

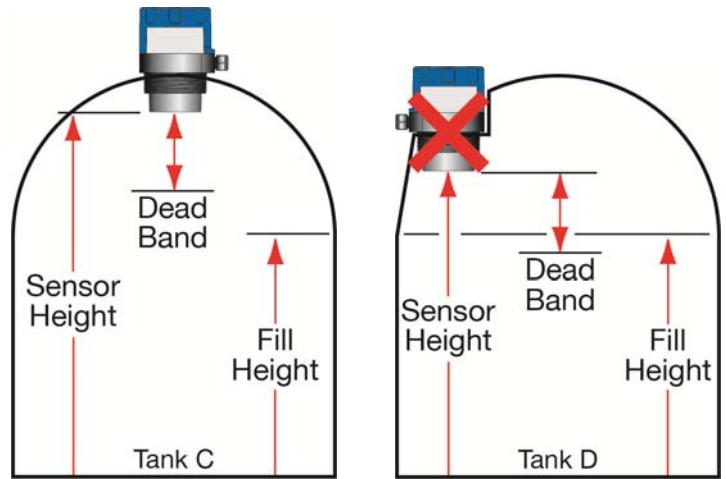

**Example #3 – Horizontal Tanks**

**Tank E** is a horizontal tank with a rounded top. The highest value for Fill-Height can be calculated by subtracting the Dead Band from the Sensor Height.

$$\text{Fill-Height} = \text{Sensor Height} - \text{Dead Band}$$

**Tank F** is another horizontal tank with a riser that matches the dead band of the sensor. In this case, the Fill-Height will be set to the top of the tank.

**Note:** The ratio of height to diameter of the riser must be no greater than 2:1. Any higher and the sensor will target the inside wall of the riser.

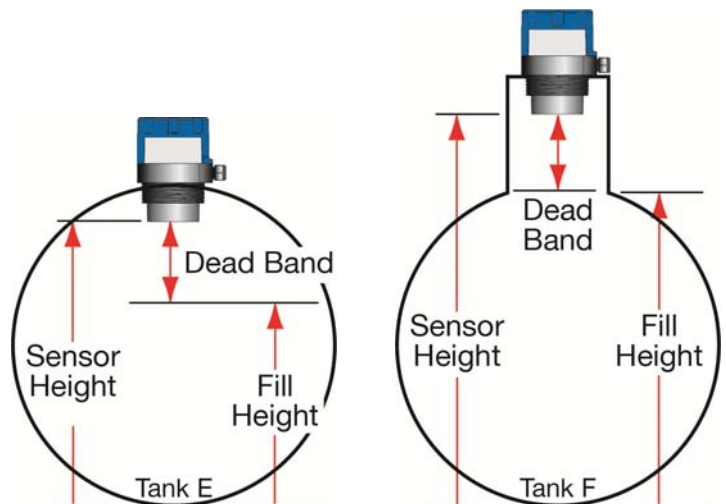

**Example #4 – Cone Bottom Tank**

**Tank G** and **Tank H** are both vertical tanks that are being supported above ground level with tank stands. The location of the Sensor Height (Tank G - bottom of tank or Tank H – ground level) will influence the Fill-Height setting.

**Note:** Fill-Height *must* always be referenced to the lowest location of the Sensor Height.

Since **Tank G** is off of the ground, the lowest location may be difficult to identify/measure. This location is required if the Volumetric Mode in WebCal® is used.

**Tank H** uses ground level as the main reference location. This method is easiest to use and ideal for using the Distance Mode of WebCal®.

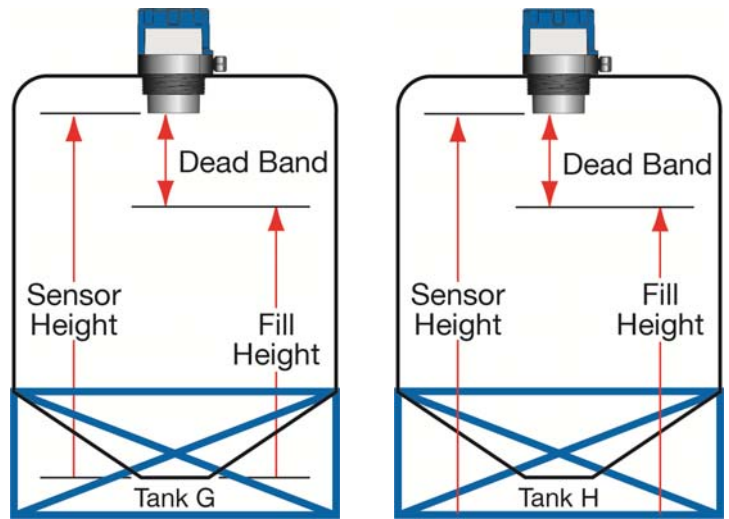

**Cone and Rounded Bottom Tanks**

The location of an EchoPod® installed along the top of a cone or rounded bottom tank may have an effect on the installation of the sensor. Be sure to understand the geometry directly underneath the sensor. Cone or rounded bottom tanks will provide off angled surfaces that can reflect the ultrasonic sound energy away from the sensor as the liquid level is lowered.

#1 Center of Cone

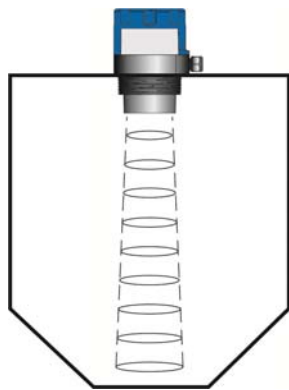

#2 Above an Angled Tank Bottom (straight side only)

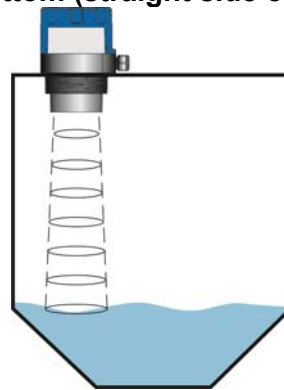

#3 Above an Angled Tank Bottom (full range)

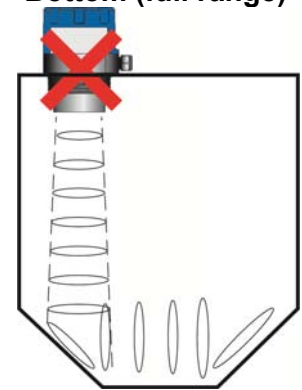

<p><b>Tank Geometry</b></p>	<p>Does not impede sensor's performance. Sensor is able to track the entire range of the tank.</p>	<p>Does not impede sensor's performance as long as the level remains within the straight side of the tank wall.</p>	<p>Does impede sensor's performance. The angled bottom will reflect ultrasonic energy away from the sensor.</p>
<p><b>Distance Reading</b></p>	<p><b>Sensor Height</b> is typically set to the bottom of the tank. Sensor will track the full range of the tank.</p>	<p><b>Sensor Height</b> is typically set to the bottom of the straight side. Sensor will only tack the straight side of the tank.</p>	<p><b>Sensor Height</b> is set to the bottom of the tank; the sensor will function as long as the level is within the straight side of the tank.</p>

**SENSOR OUTPUT TO LOCAL DISPLAY/CONTROLLER**

EchoPod® outputs a 4-20 mA signal to a local display/controller or to remote devices such as PLCs, SCADA, DCS or other displays/controllers. The 4-20 mA signal is set relative to the Sensor Height and Fill-Height settings. These settings create an operational range that can be translated into a level reading in defined units (i.e. inches, feet, gallons, meters, liters, etc.).

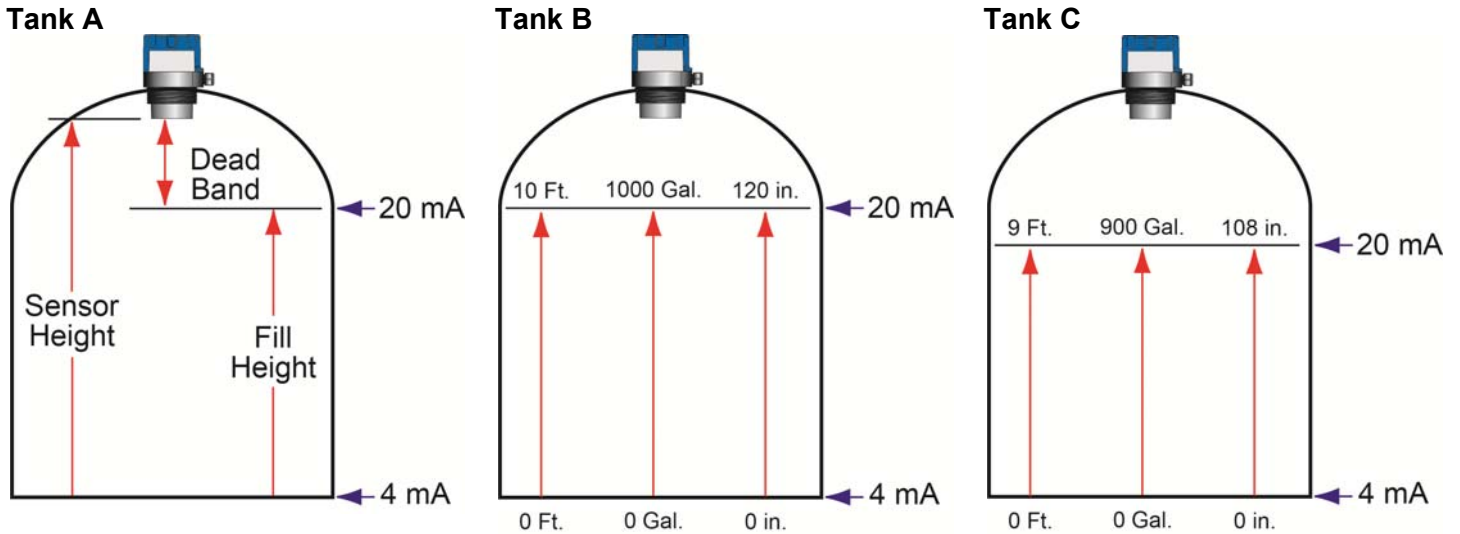

In the **Tank A** example, the Sensor Height sets the 4mA to the bottom of the tank. Fill-Height sets the 20mA to the top of the straight side of the tank.

In the **Tank B** example, the 4-20mA sensor range is correlated to actual units of level measurement. The operational range now will have engineering values of 0 to 10 feet or 0 to 1000 gallons or 0 to 120 inches.

In the **Tank C** example, the 20mA setting was lowered by 1 foot, so the engineering values for the new shorter operational ranges are either 0 to 9 feet, 0 to 900 gallons or 0 to 108 inches.

EchoPod® can be configured before installation. The transmitter features non-volatile memory, so any setting configured before installation will not be lost when the switch is powered down. To configure, follow the steps below:

1. Install WebCal® software
  - a. Go to [www.flowline.com/webCal-software/](http://www.flowline.com/webCal-software/) and select language version.
  - b. Review how USB® Fob interfaces with EchoPod® and your computer.
2. Measure the Tank
  - a. Begin by measuring the key tank and fitting dimensions.
  - b. Include all settings for each relay.
  - c. Correct tank dimensions will result in accurate sensor measurement.
3. Sensor Configuration
  - a. Configures Number of Pumps, Pump/Valve Action, Pump/Valve Mode, Relay Fail-Safe, Switch/Alarm Configuration, Switch Hysteresis/Dead Band, Loop Fail-Safe & Output at Empty for the sensor.
4. Dimensional Entry
  - a. Distance Mode (default)
    - i. Basic information for operation (Sensor Height & Fill-Height).
    - ii. Relay activation settings.
5. Tank Level Confirmation
  - a. Confirm the values are accurate for the application.
6. Write to Unit
  - a. Uploads configuration into the sensor.
  - b. Access to a customer wiring diagram specific to the relay configuration.

**STEP 1 – INSTALL WEBCAL® SOFTWARE**

EchoPod® is configured through WebCal®, a PC software program. WebCal® is a free download from Flowline’s website. **You must download and install WebCal® prior to plugging in the USB® Fob (LI99-2001).** Please go to [.flowline.com/webcal-software/](http://.flowline.com/webcal-software/), and select your language version.



**WebCal® Software**

WebCal software is a PC utility program that enables users to easily configure and test compatible Flowline level sensors to their measurement and control requirements. Download your free copy in English or Chinese and connect your sensor through our Fob USB® adapter. Sensors are sold with and without Fobs. When connected to your level sensor, WebCal displays the factory or user configuration that was last written to the sensors non-volatile memory.

**System Requirements**

- Windows® XP, Vista, 7, 8
- 32 or 64-bit system
- USB® 2.0
- 10 mB hard disk space
- 256 mB RAM

**Sensor Configuration**



**Downloads**

- English
  - WebCal Software
  - Manual
- Chinese
  - WebCal 軟件

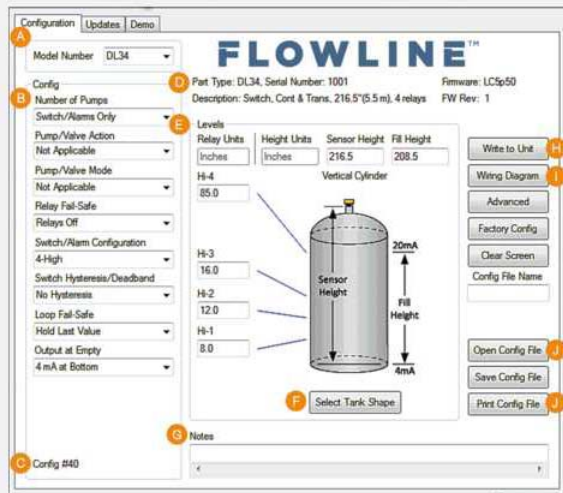

- A** Configure your sensor, update the firmware or demo your configuration prior to installation
- B** Select from preprogrammed drop down menus to create your level configuration
- C** Supports up to 175 sensor configurations
- D** View your sensor part number, serial number, description and firmware
- E** Customize set points to your level measurement or control requirements
- F** Change the proportional signal output from distance to linearized volume using the standard tank shapes or custom strapping table

**WEBCAL® SYSTEM REQUIREMENTS**

- Windows® 2000, XP, Vista, 7, 8, 10
- 32 or 64-bit system
- 1 USB® 2.0 port
- 10 mB hard drive space
- 256 mB RAM
- Internet connection

**\* For complete information on the WebCal® software, please refer to the WebCal® manual located at [www.flowline.com/webcal-software/](http://www.flowline.com/webcal-software/).**

**USB® FOB INTERFACE**

EchoPod® communicates with WebCal®\* through a USB® interface called a Fob (LI99-2001). Before plugging your Fob into your computer’s USB® port, be sure that you have installed WebCal® (see [www.flowline.com/webcal-software/](http://www.flowline.com/webcal-software/)) on your computer.

Connect the red, green, white and black wires from EchoPod® into the correct terminals on the Fob. Tighten the screws on the terminals. Plug your Fob into the USB® port of your computer.

**Wiring to Fob (LI99-2001)**

**LI99-2001 USB® Fob**

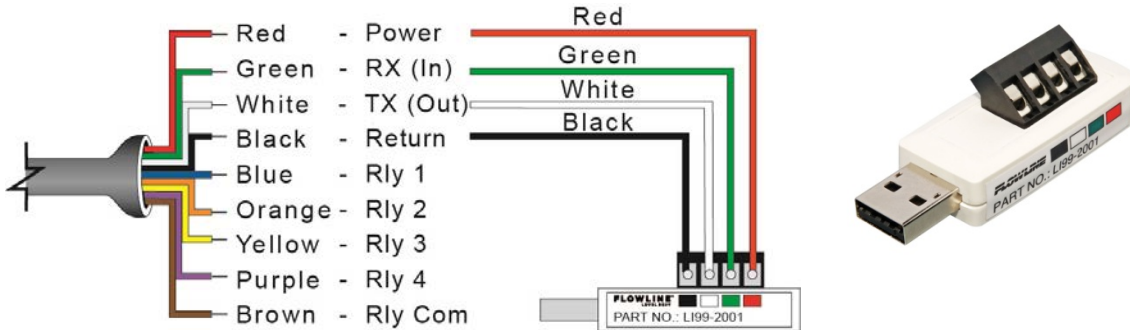

**Wiring is identical for all EchoPod® Series – Use only the Red, Black, Green and White wires.**

- The maximum cable distance between the computer and EchoPod® is 15’. This only applies for configuring the EchoPod®.
- Once EchoPod® is configured and prior to installation, isolate the white and green wires from active power to prevent a short from the configuration circuit.
- **Note:** When using the Fob, do not add VDC or VAC power. The Fob, when connected to the computer, will provide the required power to the EchoPod®.
- **\* For complete information on the WebCal® software, please refer to the WebCal® manual located at [www.flowline.com/webcal-software/](http://www.flowline.com/webcal-software/).**



**STEP 2 - MEASURE THE TANK**

Measuring the tank is one of the most important aspects in configuring the sensor. When measuring the tank, take into account the location of the sensor with respect to fittings, risers, dome tops and bottoms, and identify where the measurements are taken from the sensor. The Sensor Height is influenced by the installation location. Sensors mounted along the sloped portion of the tank will result in a lower (**HEIGHT**) value. On the other hand, sensors installed in risers/nozzles will result in a higher (**HEIGHT**) value.

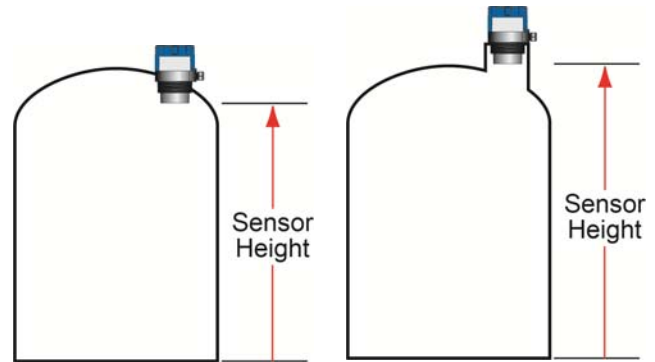

The basic measurements (**Height** and **Fill-H**) for configuration are described below:

1. **HEIGHT** (Sensor Height) - Distance from the Bottom of Sensor (sensor's measurement location) to the bottom of the tank.
  - a. The Sensor Height is typically set to the bottom of the tank.
  - b. This setting determines the 4mA location.
2. **FILL-H** (Fill-Height) - Distance from the bottom of the tank to the level of liquid where the tank is full is **FILL-H**.
  - a. The **FILL-H** is typically set to the liquid full level.
  - b. This setting determines the 20 mA location.
  - c. 20mA cannot be set within the sensor's dead band [8" (20cm) from bottom of sensor]. Largest **FILL-H** value will be as follows:

$$\text{Largest FILL-H} = \text{HEIGHT} - 8" (20\text{cm})$$

3. **Relay Set Points** – Distance from the bottom of the tank to the level of liquid where each relay activates.
  - a. Pumps/Valves have two set points, one for ON and the other for OFF.
  - b. Alarms have one set point which can be used as a high alarm (energized with level above set point) or a low alarm (energized with level below set point).
  - c. Independent Relays each have two set points, one for ON and the other for OFF.

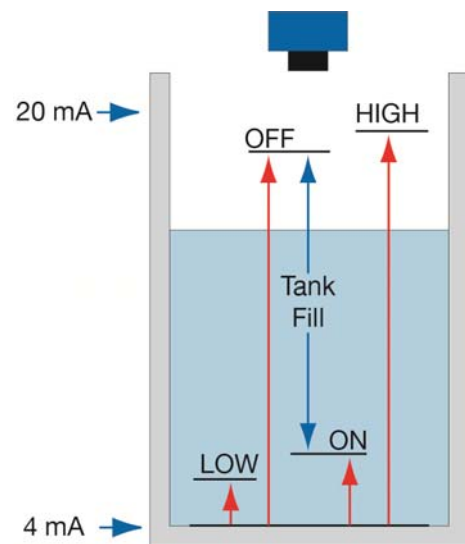
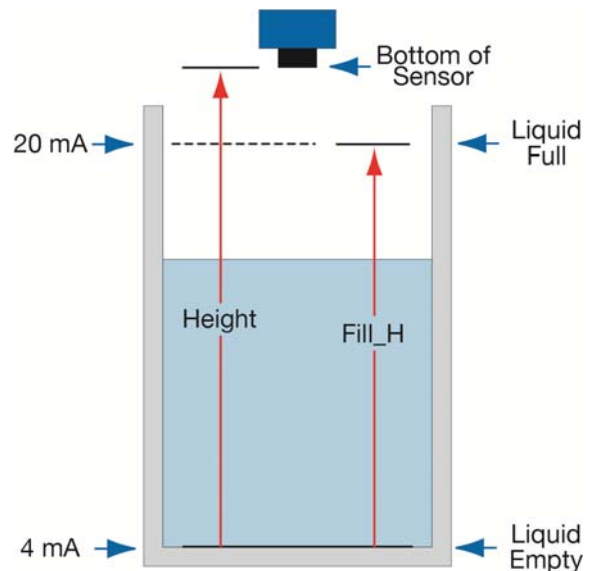

With EchoPod<sup>®</sup> connected to your computer, open the WebCal<sup>®</sup>\* software by clicking on the WebCal<sup>®</sup> icon. Follow steps 1-4 to configure the transmitter. Click “Help” in the lower right hand corner and open the help menu of WebCal<sup>®</sup> for instructions on WebCal<sup>®</sup>. If you need additional assistance using WebCal<sup>®</sup>, please contact a Flowline sales applications engineer at (562) 598-3015. **Note:** For complete information on the WebCal<sup>®</sup> software, please refer to the WebCal<sup>®</sup> manual located at [.flowline.com/webcal-software/](http://.flowline.com/webcal-software/).

**STEP 3 – SENSOR CONFIGURATION:**

Configures the relays in terms of pump/valve operations and level alarms as well as the setting fail-safe for relays and signal output. Refer to **SENSOR CONFIGURATION** on page 30 for detailed information on the different settings.

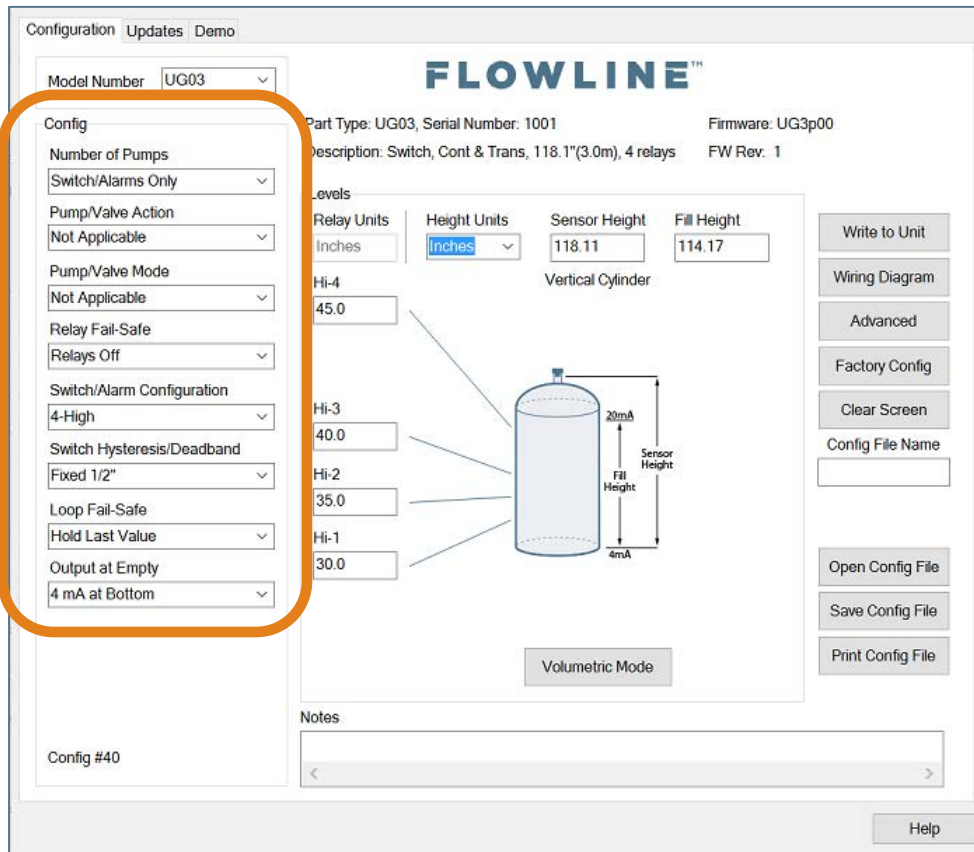

STEP 4 – DIMENSIONAL ENTRY:

**Distance Mode (default):** Output of sensor is based on the distance (height of liquid) in the tank. Any change in liquid level will reflect linearly to the current output. **Note:** Most applications will fall into this category. For Volumetric outputs, refer to **VOLUMETRIC CONFIGURATION** on page 40. The two values (Sensor Height and Fill-Height) below set the 4-20 mA current span for the sensor. Both values will be set in the units shown under Height Units.

**Height Units:** Confirm units for use in Sensor Height and Fill-Height settings.

**Sensor Height:** Sets the location for 4mA. It is based on the distance from the Empty level position to the Measurement location for the sensor (see below).

**Fill-Height:** Sets the location for 20mA. It is based on the distance from the Empty level position to the Full level position (see below).

**Relay Units:** Confirm units for use in setting the relays.

**Relay Settings:** Sets the location for each relay activation point. All values are based upon the distance or volume from Empty level position. Each setting will have a descriptor for its function. I.E. Hi-1 for high level alarm #1 or Lo-2 for low level alarm #2. **Note:** Units for the relays are independent of the units used for Sensor Height and Fill-Height.

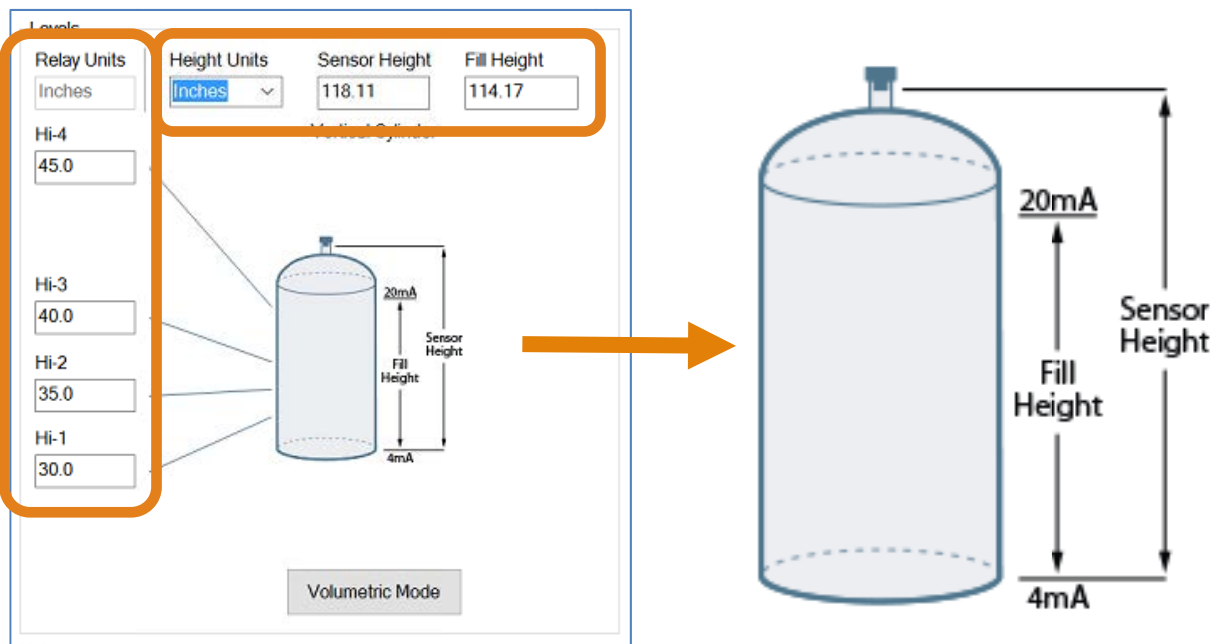

**STEP 5 – TANK LEVEL CONFIRMATION:**

Verify the Height Units, Sensor Height, Fill-Height, Relay Units & Relay Settings. All values were calculated and set in the previous Dimensional Entry window. Make any adjustments if required.

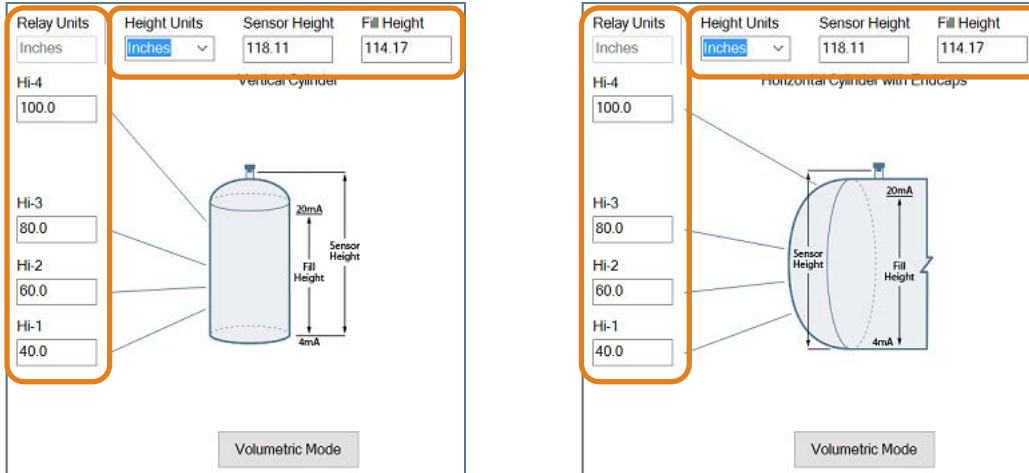

**STEP 6 – WRITE TO UNIT:**

This WebCal<sup>®</sup>\* operation uploads configuration into the sensor. Other features in the section include providing a custom wiring diagram specific to the signal output and saving the configuration file to your hard drive.

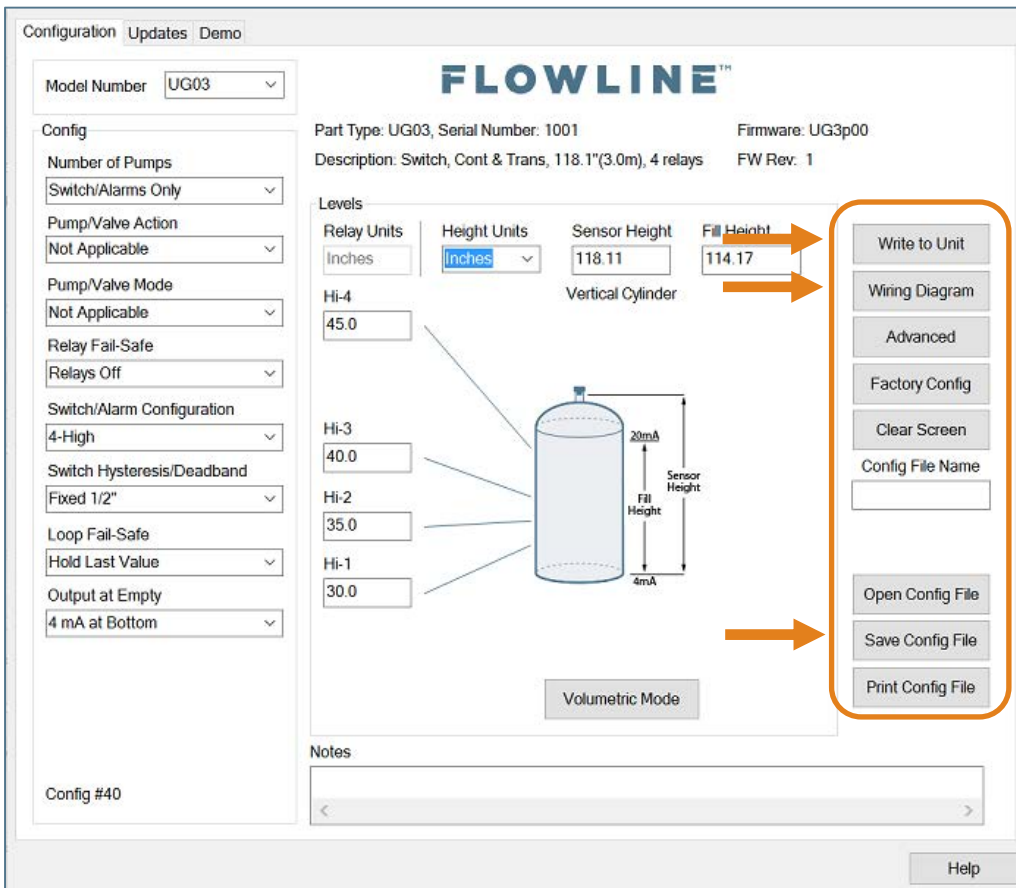

\* For complete information on the WebCal<sup>®</sup> software, please refer to the WebCal<sup>®</sup> manual located at [flowline.com/webcal-software/](http://flowline.com/webcal-software/).

EchoPod® should always be mounted perpendicular to the liquid surface (use the provided Viton® mounting gasket for G threaded versions only). Make sure that the fitting and transmitter threads are not damaged or worn. Always *hand-tighten* the transmitter within the fitting. Perform an installed leak test under normal process conditions prior to system start up.

## MOUNTING GUIDE

1. Do not mount at an angle
2. Liquid should never enter the dead band
3. Side Wall:
  - a. Mount at least 3" from the side wall
4. Do not mount where obstacles will intrude on sensor's beam width
  - a. mount at least 3" from the side wall
5. Do not mount in a vacuum
6. Avoid mounting in the center of a dome top tank.
7. In cone bottom tank, position the sensor over the deepest part of the tank.

**Installation in existing fittings:** If the existing fitting is larger than the threads of the EchoPod®, select a reducer bushing such as the LM52-2400 (3" thread x 2" thread) or LM52-3400 (4" thread x 2" thread).



LM52-2400

<p><i>Do not install at an angle relative to the liquid.</i></p>	
<p><i>Do not install within 3" of tank sidewall.</i></p>	
<p><i>Do not install with objects in the beam.</i></p>	
<p><i>Do not install in applications with vacuum.</i></p>	

**FITTING SELECTION**

Check the part number to determine the required fitting mount size and thread type. EchoPod® is commonly installed in tank adapters, flanges, brackets or standpipes. **Note:** Always include the gasket when installing the EchoPod®.

1. **Tank Adapter:** Select a tank adapter fitting, such as the LM52-2890 tank adapter.
  - a. For best results, select a 3" tank adapter and add a reducer bushing such as the LM52-2400, thread x thread, reducer bushing.
  - b. Avoid tank adapter (thread x thread) styles and/or pipe stops forward of the installed transducer.
  - c. Always mount the tank adapter so the majority of fitting is outside the tank.
    - i. **Note:** Never mount the tank adapter upside down or where the bulk of the material is inside the tank.

**2" Tank Adapter  
Socket x Thread  
(LM52-2890)**



**Tank Adapter  
w/ 3"x2" Reducer  
Bushing  
(LM52-3890 w/LM52-2400)**



**Tank Adapter  
Thread x Thread**



**Do not use thread x thread**

2. **Riser:** Installations with tall, narrow risers can impede the acoustic signal.
  - a. **Core Out Concrete:** Applications where a tank with a concrete ceiling that has been cored out can also be considered as a riser type application. In these applications follow a 2:1 ratio (Inner Diameter to Core Height) for the diameter of the core.
  - a. 2" (5 cm) diameter risers should be no taller than 5" (12.7 cm). Larger diameter risers should be no taller than 12" (30.5 cm).

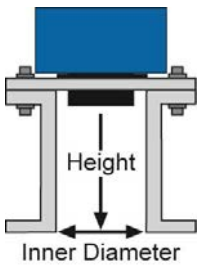
	Riser Specifications	
	Inner Diameter	Maximum Height
	2" (5cm)	3" (7.6cm)
	4" (10cm)	8" (20cm)
	6" (15cm)	12" (30cm)

**Note:** Do not exceed the dimensions listed above.



**Note:** If attempting to raise the sensor above the top of the tank to allow for a higher fill capacity, avoid the use of tall and narrow risers. The example to the left exceeds the dimensions listed in the **Riser Specifications** chart. Use a larger tank adapter which takes into account the **Riser Specifications**.

3. **Flange:** If installing on a flange, select a flange with a minimum thread of 2" thread that is above the plane of the flange, such as the LM52-2850.
  - a. Use a flange with a 3" thread and add a 3" to 2" reducer bushing to complete the installation.

**2" Flange w/  
thread out of plane  
(LM52-2850)**



**3" Flange w/  
Reducer Bushing  
(LM52-3800)**



4. **Side Mount Bracket:** For installations in open tanks and sumps, use the LM50-1001 series side mount bracket.

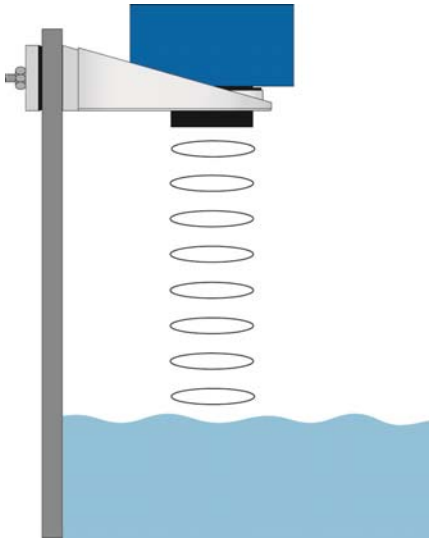

LM50-1001 Shown

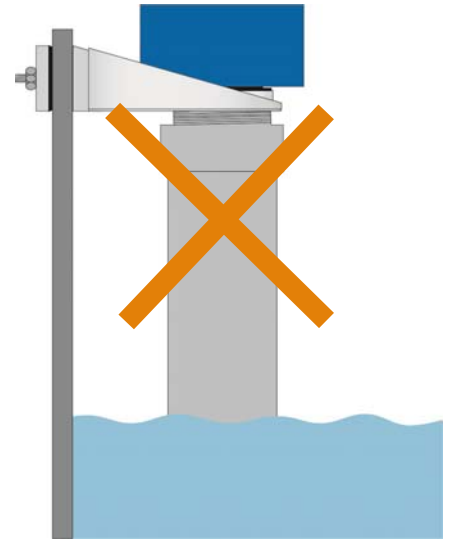

**5. Stand Pipe:** A standpipe maybe used to dampen turbulence or when foam is present in the application.

- a) Pipe can be constructed from any material.
- b) Select a minimum 3" ID pipe or greater for the stand pipe.
- c) Use a coupling and reducer bushing to attach the EchoPod® to the pipe.
  - i) Use a reducer bushing such as LM52-2400 (3" Thread x 2" Thread) fitting or the LM52-2410 (3" Slip x 2" Thread) fitting.
- d) The pipe length should run the measurement span. The bottom of the pipe should remain submerged at all times to prevent foam from entering the pipe.
- e) Cut a 45° notch at the bottom of the pipe. Drill a 1/4" pressure equalization hole in the dead band.
- f) The pumps should not drive liquid past the open end of the stand pipe which causes the liquid in the pipe to oscillate.

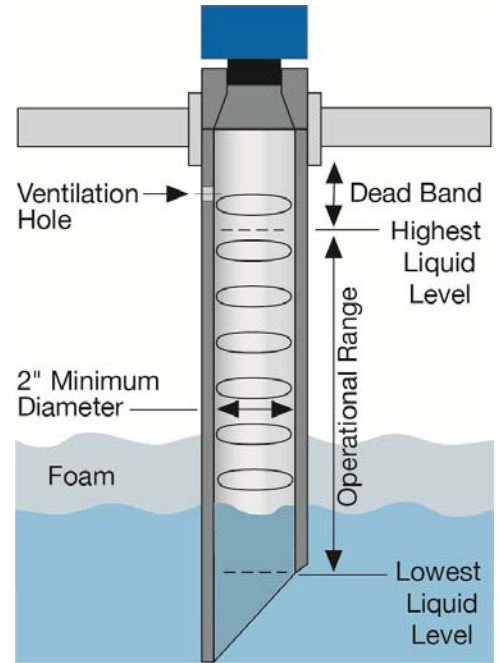

**Note:** Never allow the bottom of the stand pipe to become exposed to air. This will break the liquid seal which will prevent echoes from returning back to the sensor.

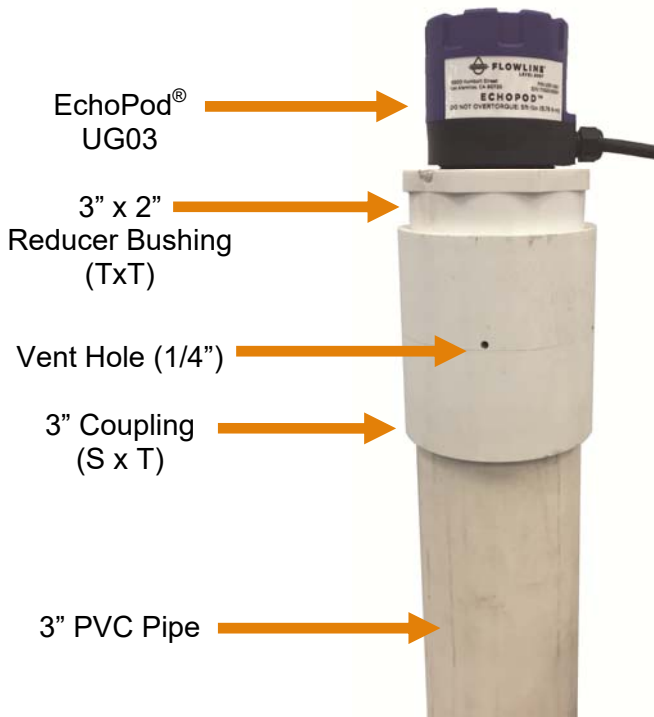

EchoPod® attached to a LM52-2400 (3" x 2" reducer bushing) to a Slip x Thread 3" Coupling.



Avoid the use of a tee within the stand pipe. A tee can create false signals impeding the sensor's performance.



WIRING DIAGRAM - SAMPLE

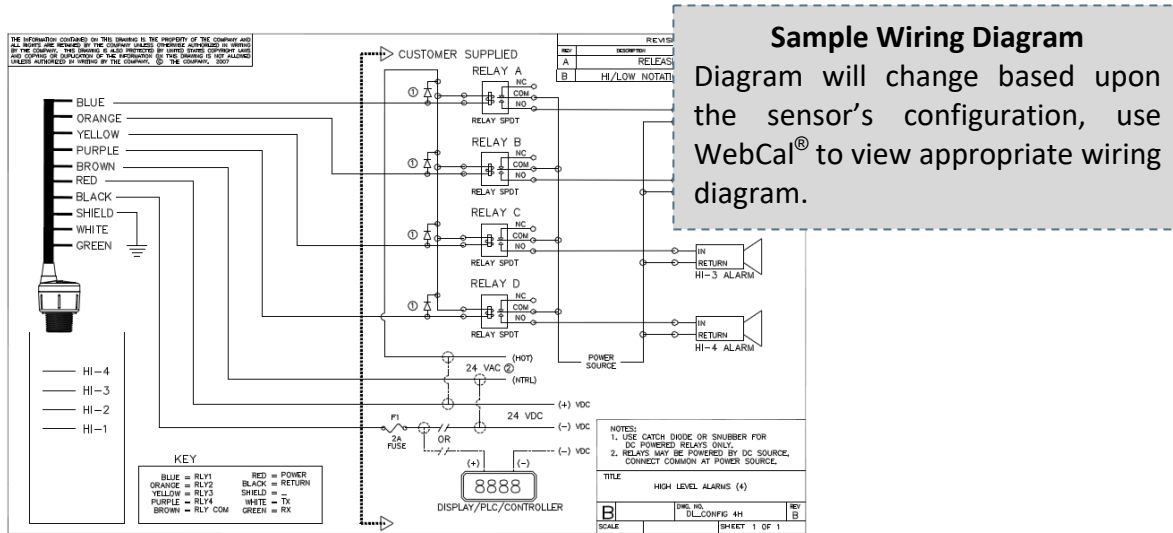

WIRING ECHOPOD®

Once EchoPod® has been configured; follow the Wiring Diagram provided by the WebCal® software. A typical wiring diagram is shown above. Flowline recommends using a qualified licensed electrician to wire EchoPod® with your application’s components.

- ⚠ Configure your EchoPod® with WebCal® and use the wiring diagram button to view the appropriate diagram. Each configuration will have its own unique diagram. The diagram shown above is only a sample and should not be used as a wiring diagram.
- ⚠ Always use stepper relays between the sensor and external loads. For DC circuits, always use a catch diode such as 1N4148, shown on the Wiring diagram above supplied by WebCal®.
- ⚠ Once EchoPod® is configured, isolate the white and green wires from active power to prevent a short of the configuration circuit.

## WIRE CONNECTIONS

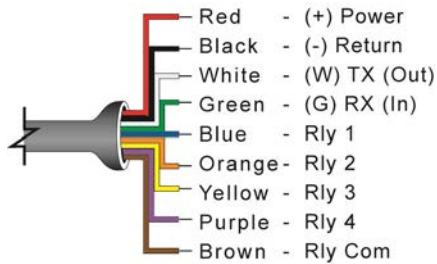

## UG01 and UG03 Series

**Red (+) & Black (-):** Red [(+) Power] and Black [(-) Return] leads are for connection to a 24 VDC power supply or to a 4-20 mA loop power source. The red and black wires can be extended up to 1,000 feet using a 22-gauge or larger wire.

**White & Green:** White [(W) TX] and Green [(G) RX] leads are reserved for use with WebCal<sup>®</sup> and also to communicate to PodView<sup>®</sup>. These wires should only be connected to one device at a time (i.e. only to WebCal<sup>®</sup> or PodView<sup>®</sup>). In addition, these wires should not be connected to WebCal<sup>®</sup> while power is supplied from any source other than the LI99-2001 series Fob. The maximum cable distance between the computer and EchoPod<sup>®</sup> is 15'. **Note:** *Never allow the white or green wires to touch any power supply.*

**Blue, Orange, Yellow, Purple & Brown – (UG01 & UG03 Series only):** Blue (RLY1), Orange (RLY2), Yellow (RLY3) & Purple (RLY4) wires are the relay contacts (normally open) from each of the relays respectively. The Brown wire (RLY Common) is the common for all the relays. Relay selection is determined by the configuration in WebCal<sup>®</sup>.

*EchoPod<sup>®</sup> (UG01 & UG03 series only) uses latching relays. When power is removed to the sensor, the relays will remain in their last state. Ex: If the relay is energized, when power is removed, the relay will remain in an energized state.*

## GENERAL NOTES FOR ELECTRICAL CONNECTIONS, USAGE AND SAFETY

- **Where personal safety or significant property damage can occur due to a spill, the installation must have a redundant backup safety system.**
- Wiring should always be completed by a licensed electrician.
- Supply voltage should never exceed 28 VDC.
- Do not exceed 28 VDC power on the relays within EchoPod<sup>®</sup>.
- Always use stepper relays between the sensor and external loads. For DC circuits use a catch diode such as 1N4148, shown on the previous page.
- Protect the sensor from excessive electrical spikes by isolating the power, whenever possible.
- The sensor materials must be chemically compatible with the liquids to be measured.
- Design a fail-safe system for possible sensor and/or power failure.
  - During power failure, relays will remain in their current state and will not change until power is restored and the signal is reacquired.
- **Never use the sensor in environments classified as hazardous.**

**COMMON WIRING TO DISPLAY, CONTROLLERS & PLC'S**

Below is a quick review of wiring the EchoPod® to common display, controllers and PLC's.

**DataView™ LI55 Series  
Level Controller**

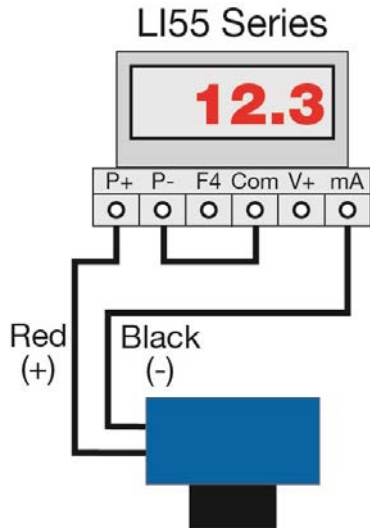

**Commander™ LI90 Series  
Multi-Tank Level Controller**

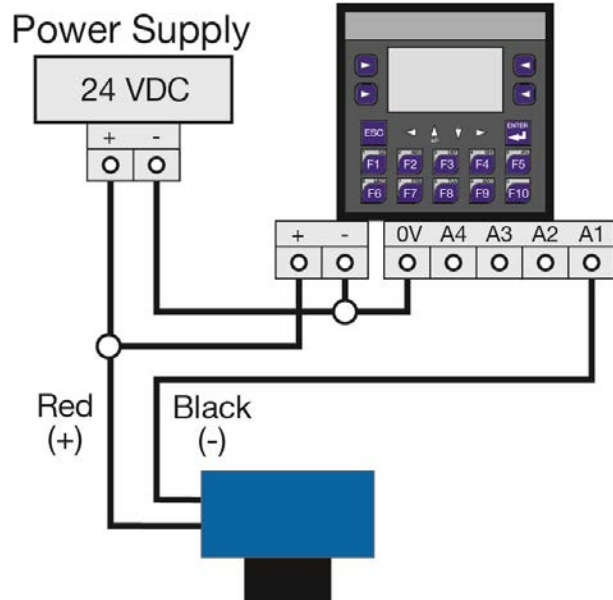

**DataLoop™ LI25 Series  
Level Indicator  
without the backlight**

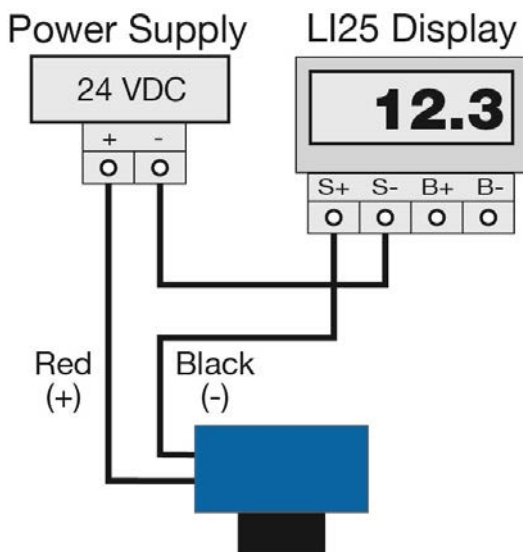

**DataLoop™ LI25 Series  
Level Indicator  
with the backlight**

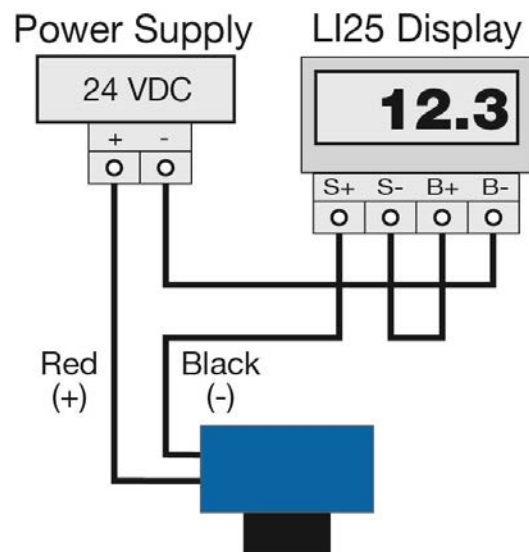

COMMON WIRING TO DISPLAY, CONTROLLERS & PLC'S (CONTINUED)

**DataPoint™ LC52 Series  
Level Controller  
\*JWA mode (Factory Setting)**

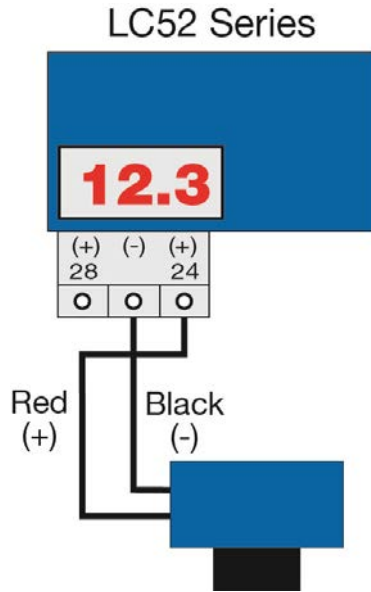

**DataPoint™ LC52 Series  
Level Controller  
\*JWB mode**

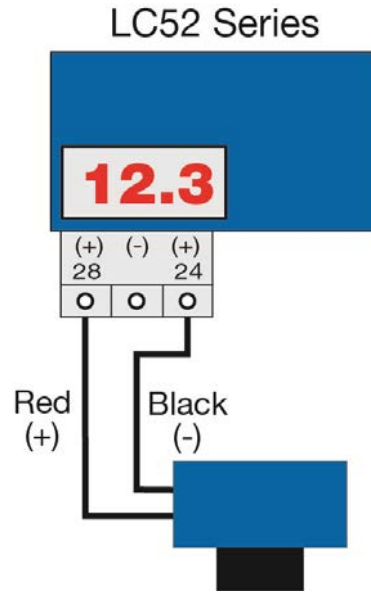

**Generic Loop  
Powered Display**

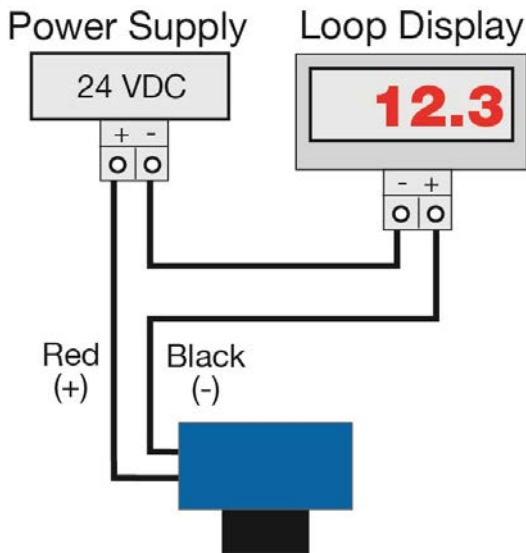

**Generic PLC**

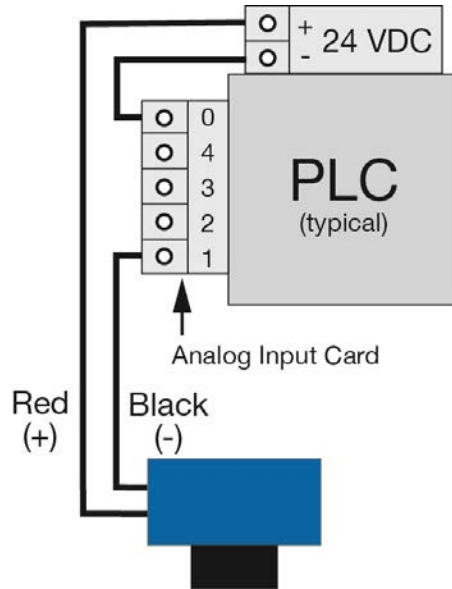

\* Refer to the DataPoint™, LC52 Series, Level Controller manual for information on JWA mode and JWB mode settings in the controller.

**SWITCHING INDUCTIVE LOADS**

The use of suppressors (snubbers) is always recommended when switching inductive loads to prevent disrupting the microprocessor’s operation. The suppressors also prolong the life of the relay contacts. Suppression can be obtained with a catch diode for DC circuits and a resistor-capacitor (RC) for AC circuits.

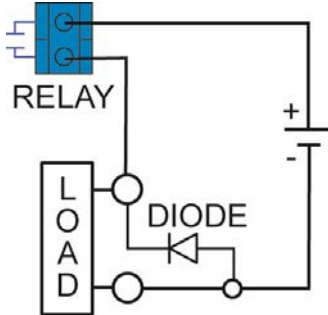

**Catch Diode**

- Always use stepper relays between the sensor and external loads. For DC circuits always use a catch diode such as 1N4148, shown on left.

Refer to the following circuits for RC network assembly and installation:

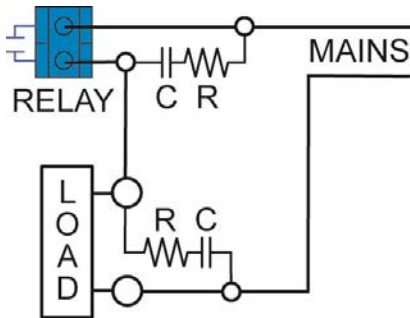

**Choose R and C as follows:**

- R: 0.5 to 1 Ohms for each volt across the contacts
- C: 0.5 to 1  $\mu$ F for each amp through closed contacts

**Notes:**

1. Use capacitors rated for 250 VAC.
2. RC networks may affect load release time of solenoid loads. Check to confirm proper operation.
3. Install the RC network at the meters relay screw terminals. An RC network may also be installed across the load. Experiment for best results.

**VOLTAGE OUTPUT**

EchoPod® can be configured as a 0 to 5 output. A resistor will need to be added to the circuit to enable a voltage output (refer to the wiring diagram below).

- 0-5 VDC output
  - Add a 250 Ohm resistor
  - Actual output will be 0.8 to 5 VDC

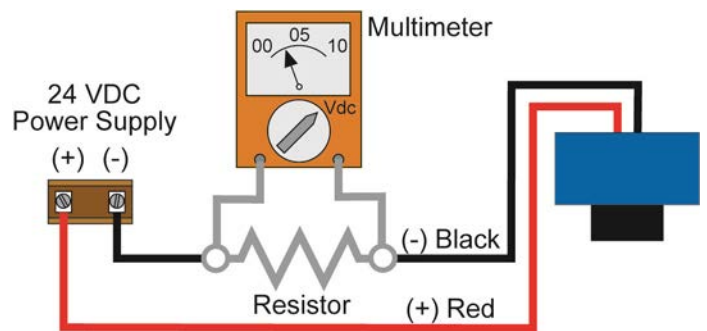

This section of WebCal® is where you select the sensor configuration settings. Start from the top and work to the bottom, choosing the selections that are applicable to your configuration. “**Not Applicable**” will automatically show when a selection doesn’t apply to your configuration settings, and you may move on. All configuration settings must be selected or have “**Not Applicable**” before you can continue to the next step.

**SENSOR CONFIGURATION**

**NUMBER OF PUMPS**

This feature allows you to select the number of pumps or valves used with EchoPod®. This setting activates the control capabilities of one or two relays. Control relays are often referred to as latching relays.

- **Switch/Alarms Only** – The relays will be standard single point non-latching relays. Use this setting for high and/or low alarms.
- **1-Pump/Valve** – One relay will be configured as a control or latching relay (relay will have a start level and a separate stop level). Use this setting to control one pump or valve for automatic filling or emptying of a tank.
- **2-Pumps/Valves** – Two relays are configured as control or latching relays. Each relay will have a unique start level and a common stop level. Use this setting to control two pumps or valves for automatic filling or emptying of a tank.
- **4-20mA Transmitter Only** – This setting will disengage all of the relays. Use this function if you are not using any relays and using only the 4-20 mA current output.
- **Independent Relays** – This setting will override the Switch/Alarm Configuration and allow all 4 relays to be set independent of the other relays. Each relay will have its own unique ON and OFF setting (see below).

**Note:** Right click on any item to open the help menu.

**Note:** To reset the configuration table, press the Clear Screen button.

Config

Number of Pumps  
2-Pumps/Valves

Pump/Valve Action  
Empties Tank

Pump/Valve Mode  
--please select--

Relay Fail-Safe  
--please select--

Switch/Alarm Configuration  
--please select--

Switch Hysteresis/Deadband  
--please select--

Loop Fail-Safe  
--please select--

Output at Empty  
--please select--

Continue to select

**PUMP/VALVE ACTION**

This feature allows you to select whether the pumps or valves will be used to automatically fill or empty the tank. For 2-Pump/Valve mode, both devices must be used in the same (automatic fill or empty) way. You cannot set one relay for fill and the other for empty.

- **Empties Tank** – Sets the relay(s) to automatically empty a tank. The start level will be above the Stop level for each relay.
- **Fills Tank** – Sets the relay(s) to automatically fill a tank. The start level will be below the Stop level for each relay.
- **Not Applicable** – Appears when this function is not available based on previous selections.

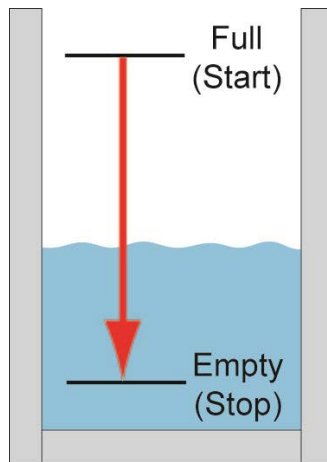

**Empties Tank  
(Auto Empty)**

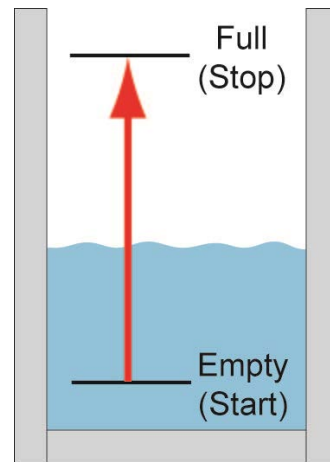

**Fills Tank  
(Auto Fill)**

**Note:** Right click on any item to open the help menu.

**Note:** To reset the configuration table, press the Clear Screen button.

Config

Number of Pumps  
2-Pumps/Valves

Pump/Valve Action  
Empties Tank

Pump/Valve Mode  
Lead/Lag

Relay Fail-Safe  
--please select--

Switch/Alarm Configuration  
--please select--

Switch Hysteresis/Deadband  
--please select--

Loop Fail-Safe  
--please select--

Output at Empty  
--please select--

Continue to select

**PUMP/VALVE MODE**

This feature allows you to select the control mode for a latching relay. Pump/Valve mode is not active for Switch/Alarms Only or 4-20 mA Transmitter Only.

- **Simplex** – Allows the relay to be used for automatic fill or empty. This is the default and only mode when **1-Pump/Valve** is selected.

- **Simplex used to Empty Tank**

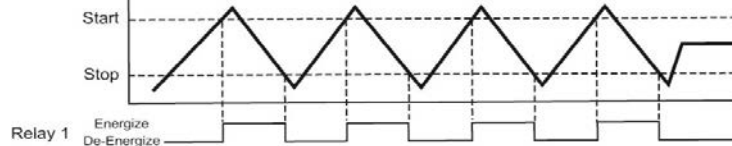

- **Lead/Lag** – Allows two relays to have unique start levels and a common stop level. The first relay will be identified as the lead relay and the second relay as the lag. Each time the lead level is reached, the first relay will always start. The lag relay will only start when the lag level is reached. All relays will stop at the common off level.

- **Lead/Lag used to Empty Tank**

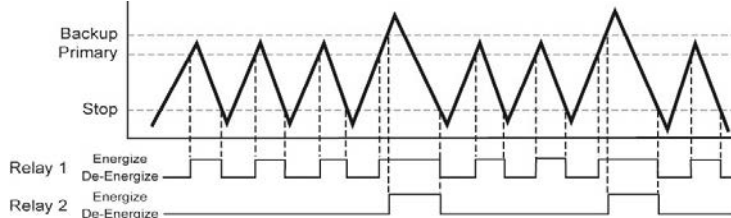

- **Duplex** – Allows two relays to have two different start levels, a common stop level and will alternate the relays when the first start level is reached. The two relays will alternate each time the lead level is reached and the remaining relay will start when the lag level is reached. All relays will stop at the common off level.

- **Duplex used to Empty Tank**

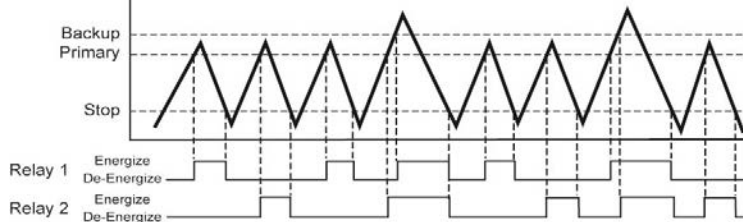

- **Not Applicable** – Appears when this function is not available based on previous selections.

**Note:** Right click on any item to open the help menu.

**Note:** To reset the configuration table, press the Clear Screen button.



Config
Number of Pumps 2-Pumps/Valves
Pump/Valve Action Empties Tank
Pump/Valve Mode Lead/Lag
Relay Fail-Safe Hold State
Switch/Alarm Configuration --please select--
Switch Hysteresis/Deadband --please select--
Loop Fail-Safe --please select--
Output at Empty --please select--
Continue to select

**RELAY FAIL-SAFE**

This feature allows you to select the fail-safe mode for the relays in the event that the sensor loses echo confidence. When the sensor regains echo confidence, the output current will revert back to the current level condition.

- **Relays Off** – The relays will revert to the OFF state. This appears when **Switch/Alarms Only** is selected.
- **Relays On** – The relays will revert to the ON state. This appears when **Switch/Alarms Only** is selected.
- **Hold State** – The relay(s) will remain in the same state as the last confident echo detected. When the sensor regains echo confidence, the relays will revert to the current level.
- **Pump/Valves Off** – The relays will revert to the OFF state. This appears when **1-Pump/Valve** or **2-Pumps/Valves** are selected.
- **Pump/Valves On** – The relays will revert to the ON state. This appears when **1-Pump/Valve** or **2-Pumps/Valves** are selected.
- **Not Applicable** – Appears when this function is not available based on previous selections.

**Note:** Right click on any item to open the help menu.

**Note:** To reset the configuration table, press the Clear Screen button.

Config

Number of Pumps  
2-Pumps/Valves

Pump/Valve Action  
Empties Tank

Pump/Valve Mode  
Lead/Lag

Relay Fail-Safe  
Hold State

Switch/Alarm Configuration  
1-Low, 1-High

Switch Hysteresis/Deadband  
--please select--

Loop Fail-Safe  
--please select--

Output at Empty  
--please select--

Finish Selections

**SWITCH/ALARM CONFIGURATION**

This feature allows you to select the relay operation for the switch / alarm (used as a high or low alarm). The number of available relays is based upon the previous settings.

- **No Alarm** – Turns OFF all remaining relays.
- **High Alarms** – Sets 1 to 4 High Alarms (**1-High, 2-High, 3-High, 4-High**).
- **Low Alarms** – Set 1 to 4 Low Alarms (**1-Low, 2-Low, 3-Low or 4-Low**).
- **Combination Alarms** – Sets a combination of High and Low Alarms (**1-Low 1-High, 1-Low 2-High, 2-Low 1-High, 2-Low 2-High, 1-Low 3-High, 3-Low 1-High**).
- **Not Applicable** – Appears when this function is not available based on previous selections.

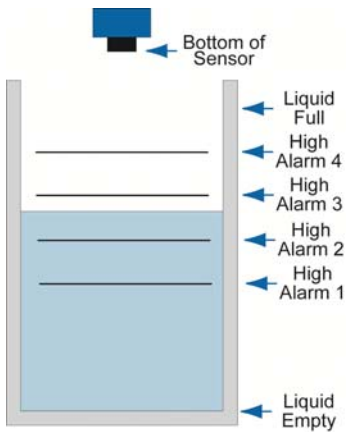

**High Alarm  
(4 High)**

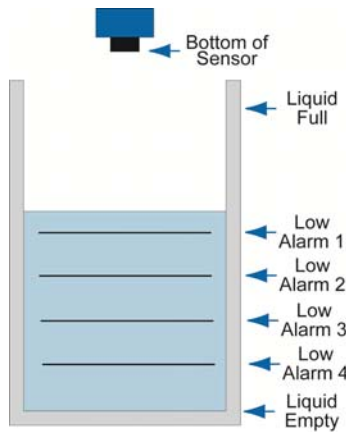

**Low Alarms  
(4 Low)**

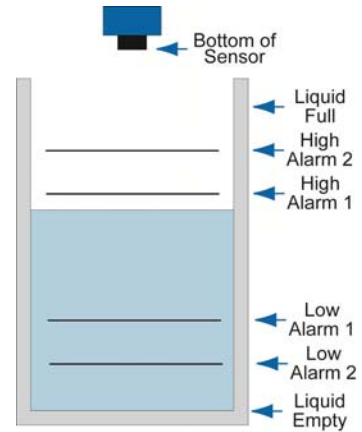

**Combination Alarms  
(2 High and 2 Low)**

**Note:** Right click on any item to open the help menu.

**Note:** To reset the configuration table, press the Clear Screen button.

Config

Number of Pumps  
2-Pumps/Valves

Pump/Valve Action  
Empties Tank

Pump/Valve Mode  
Lead/Lag

Relay Fail-Safe  
Hold State

Switch/Alarm Configuration  
1-Low, 1-High

Switch Hysteresis/Deadband  
Fixed 1/4"

Loop Fail-Safe  
--please select--

Output at Empty  
--please select--

Finish Selections

**SWITCH HYSTERESIS/DEAD BAND**

This feature allows you to select a hysteresis or dead band for the remaining high and/or low alarms.

- **Options for Hysteresis/Dead band** – No Hysteresis, 1/4", 1/2", 1", 2", 1/2 cm, 1cm, 2 cm, 5 cm or Not Applicable.
- **High Alarms** – Relay activates above the set point. Relay will deactivate when the level goes below the set point plus the value of the hysteresis.
- **Low Alarms** – Relay activates below the set point. Relay will deactivate when the level goes above the set point plus the value of the hysteresis.

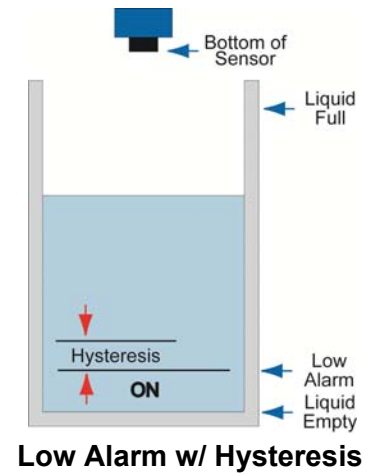
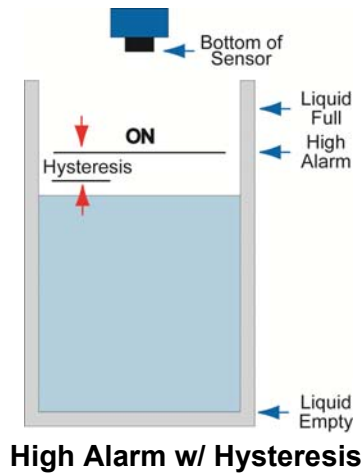

**Note:** Right click on any item to open the help menu.

**Note:** To reset the configuration table, press the Clear Screen button

**LOOP FAIL-SAFE**

This feature allows you to select the fail-safe current output if the sensor loses echo confidence. When the sensor regains echo confidence, the output current will revert back to the current level condition.

- **Hold Last Value** – The output will remain in the same state as the last validated echo detected. Example: If the output was 6.7 mA just prior to the lost signal, the sensor will continue to output 6.7 mA until echo confidence is regained.
- **Empty** - The output will revert to the current value for an empty condition. When **4 mA at Bottom** is selected, the sensor will output 4 mA during a fail-safe condition. If **20 mA at Bottom** is selected, the sensor will output 20 mA during a fail-safe condition.
- **Full** – The output will revert to the current value for a full condition. When **4 mA at Bottom** is selected, the sensor will output 20 mA during a fail-safe condition. If **20 mA at Bottom** is selected, the sensor will output 4 mA during a fail-safe condition.
- **Overfill (21mA)** – The sensor will output 21mA during a fail-safe condition.
- **Overfill (22mA)** – The sensor will output 22mA during a fail-safe condition.

**OUTPUT AT EMPTY**

This feature allows you to select the orientation of the 4 to 20mA output (4 to 20 mA or 20 to 4 mA). Choose which output setting best fits the application. Factory default is 4mA at bottom and 20mA at top, as this configuration scenario is an industry standard. *When connecting your sensor to a display, you must account for your output orientation setting.*

- **4mA at Bottom** – The output current will be 4mA when the sensor measures an empty tank and 20mA when the sensor measures a full tank.
- **20mA at Bottom** – The output current will be 20mA when the sensor measures an empty tank and 4mA when the sensor measures a full tank.

**Note:** Right click on any item to open the help menu.

**Note:** To reset the configuration table, press the Clear Screen button

**VOLUMETRIC CONFIGURATION**

The sensor may be configured in volumetric units (Gallons or Liters) or Distance (Height of Liquid) units (inches, cm, feet or meters). WebCal® will default to Distance (Height of Liquid) with units of Inches. To change units or change from Distance to Volume, press the Volumetric Mode button as located near the center of the window.

**Distance (Height of Liquid):** When this is selected, the sensor will always output a linear output proportional to the height of liquid (regardless of the tank shape). In the two drawings below, the Sensor High is set to 64" and Fill-Height is set to 60". If the tank is empty, the sensor will output 4mA. If the level is at 30", then the sensor will output 12mA. Either tank can be configured with a display from 0" to 60" and the sensor will always output the height of liquid.

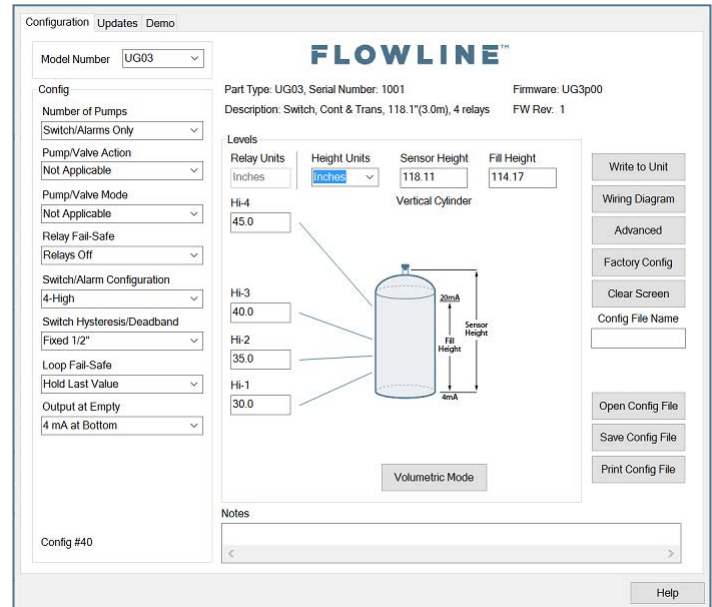

**Volume:** When volume is selected, the 4-20 mA output from the sensor will be proportional to the volume of the tank, not the height of the tank. This means that the current output will track the volume of the tank (in gallons or liters). Depending on the shape of the tank, the values may be a linear or non-linear scale. In the same examples below, the sensors are also configured with SH = 64" and FH = 60". The current output in a linear tank will act as expected with volume increase matching equal changes to level. However, the current output in the Non-Linear tank will reflect the actual changes in volume. So even though the liquid height changes incrementally the same amount, the volume change will adjust throughout the entire span of the tank. The advantage of this is that sensor does all the math so you can read tank volume using a simple two-point display/controller such as the DataLoop™ LI25 series or DataView™ LI55 series.

**Linear Tank Example**

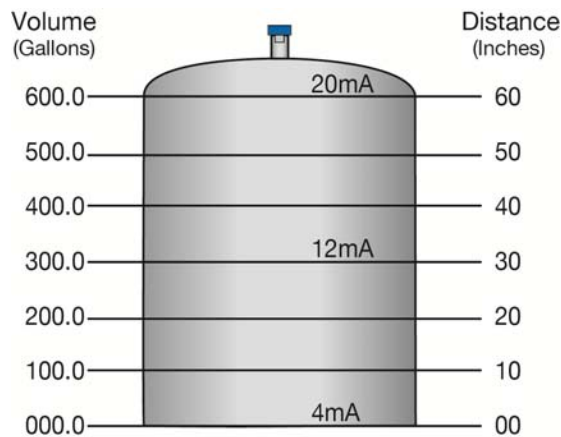

**Note:** In the above illustration, 10" of liquid will always be equal to 100 gallons of liquid (1" = 10 gallons).

**Non-Linear Tank Example**

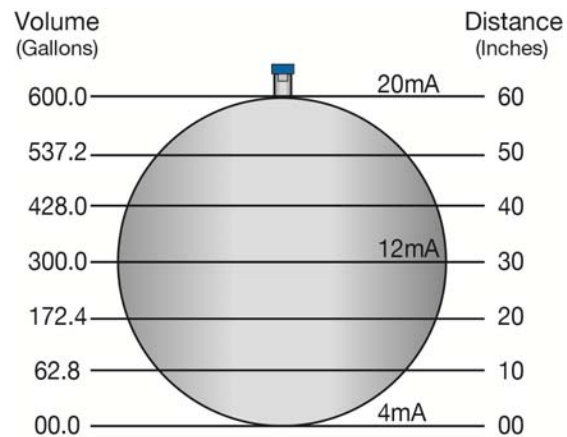

**Note:** In the above illustration, 1" of liquid does not equal 10 gallons. The 10" at the bottom represents a rise of 62.8 gallons. As a change between 10" and 20" represents an increase of 109.6 gallons (i.e. 172.4 gallons – 62.8 gallons).

**Shape Selection Window:** This window will show the different tank shape options available in WebCal®.

- **Vertical Cylinder**
- **Vertical Cylinder with Cone Bottom**
- **Horizontal Cylinder with End caps**
- **Horizontal Cylinder with Spherical Ends**
- **Spherical**
- **Rectangular**
- **Strapping Table** – Use this feature for manual entry of measured tank distances and volumes.

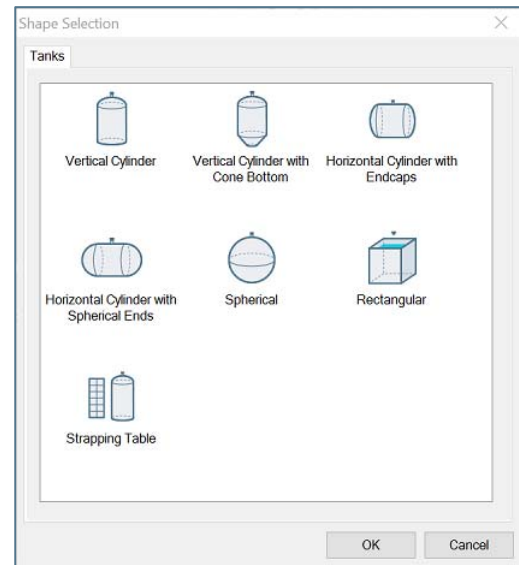

Select any of the above tank shapes and press OK to confirm.

**A. Dimensional Entry – Vertical Cylinder Example:** Choose the Sensor Output Units as Distance or Volume. After choosing the Sensor Output Units, select the units of measurement in the pull down to the left.

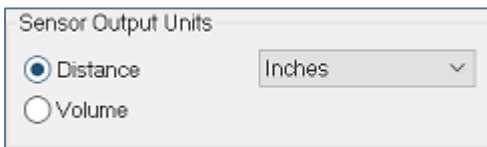

Units of Measurement	
Distance	Volume
Inches	Gallons Liters
Cm	
Feet	
Meters	

**Distance – Sensor Output Units (Vertical Cylinder Example):**

Enter the dimensions of the tank. You must enter data in all fields shown.

**Sensor Height:** Distance from the bottom of the tank to the top of the threads.

**Fill Height:** Distance from the bottom of the tank to the operational full level of liquid (20mA). This setting defines the location of full current output and is the top of the sensor’s measurement range.

**Riser Height:** Distance the sensor is above the top of the tank (including all fittings). Measured from the bottom of the sensor.

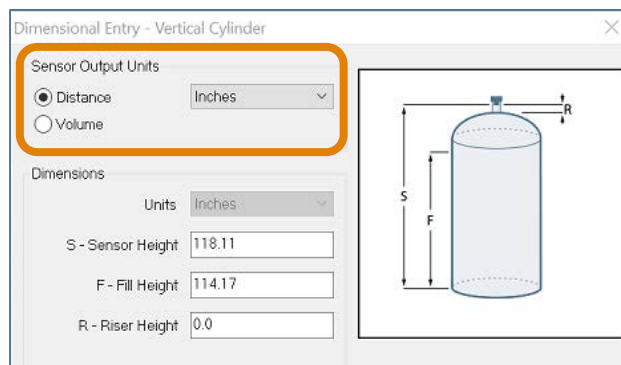

**Volume – Sensor Output Units (Vertical Cylinder Example):**

Enter the dimensions of the tank. You must enter data in all fields shown.

**Sensor Height:** Distance from the bottom of the tank to the top of the threads.

**Fill Height:** Distance from the bottom of the tank to the operational full level of liquid (20mA). This setting defines the location of full current output and is the top of the sensor’s measurement range.

**Riser Height:** Distance the sensor is above the top of the tank (including all fittings). Measured from the bottom of the sensor.

**Height:** Distance from the bottom of the tank to the top of the straight side wall.

**Diameter:** Distance of the inside tank diameter.

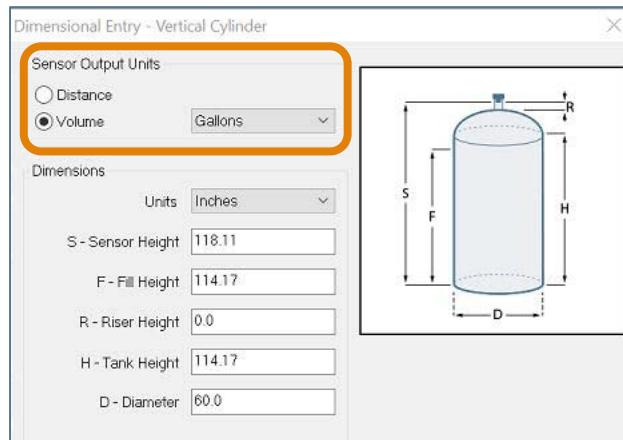

**Volume – Tank Capacity (Vertical Cylinder Example):** After entering the dimensions, press the Capacity button to show the Calculated Capacity of the tank. If the Calculated Capacity is slightly different than the expected capacity, click on the Adjust Capacity box and enter the expected capacity of the tank. If the Adjusted Capacity is more than 10% of the Calculated Capacity, recheck the dimensions information entered above.

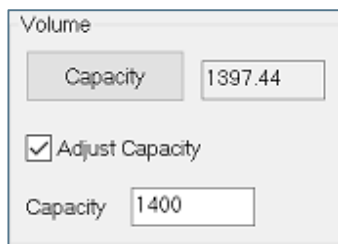
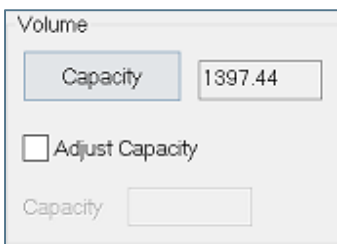

When all dimensions are entered, press the Apply button to return to the previous Configuration window.

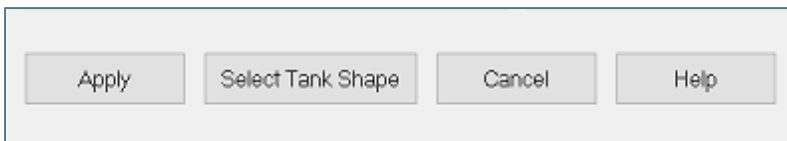

- **Apply** – Transfers the dimensions to the original Configuration window.
- **Tanks** – Returns to the previous Shape Selection window.
- **Cancel** – Returns to the Configuration window without saving any information.
- **Help** – Jumps to the Help menu.

**TANK LEVEL CONFIRMATION**

This section of WebCal® is where you confirm the values set in the previous step. The values were entered under the Dimensional entry window. To edit these settings, you must go back to the Dimensional entry window via the Volumetric Mode button.

- **Height Units:** Units selected for configuration. When used as a device to measure the distance (height of liquid), the options are inches, cm, feet or m. When used as a device to measure the volume of liquid, the options are gallons or liters.
- **Sensor Height:** Distance from the bottom of the tank to the bottom of the top of the threads.
- **Fill-Height:** Distance from the bottom of the tank to the operational full level of liquid (20mA). This setting defines the location of full current output and is the top of the sensor’s measurement range.
- **Capacity:** The total volume of the tank. Only shown when gallons or liters are selected.

**Note:** By extending the empty (4mA) to the bottom of the tank, the 4-20 mA output will track the volume of the tank. This allows any local display to read the actual volume of liquid without the need for any unique configuration. This feature is very useful with any non-linear tanks such as horizontal, spherical or tanks with cone bottoms.

The screenshot shows the configuration window for a 'Vertical Cylinder' tank. At the top, there are four main settings: 'Relay Units' set to 'Gallons', 'Height Units' set to 'Inches', 'Sensor Height' set to '118.11', and 'Fill Height' set to '114.17'. Below these are four 'Hi' settings: 'Hi-4' (1200), 'Hi-3' (1000), 'Hi-2' (800), and 'Hi-1' (600). At the bottom left, the 'Capacity' is listed as '1400.0'. A 'Volumetric Mode' button is located at the bottom center and is highlighted in blue. To the right of the interface, a callout box with a dashed border contains the text: 'Volumetric Sensor Output: The volumetric mode button will be highlighted in Blue when a volume output is selected.' Orange arrows point from text labels to the corresponding fields in the interface: 'Height Units' points to the 'Inches' field; 'Sensor Height' points to the '118.11' field; 'Fill-Height' points to the '114.17' field; 'Capacity' points to the '1400.0' field; and '\*Relay Settings' points to the 'Hi-4' through 'Hi-1' fields. A blue arrow points from the callout box to the 'Volumetric Mode' button.

\* Relay settings are based upon the configurations selected under the Config pull-down menus.



**WRITE TO UNIT**

After you have entered configurations, selected and configured the Tank Shape and entered the Tank Values, click **“Write to Unit”** and load the configuration into the memory of the sensor. When completed, this configuration will remain inside the sensor memory and will not change unless the sensor is connected to WebCal® and a new configuration is written to the sensor. Loss of power will not change or lose the configuration within sensor memory.

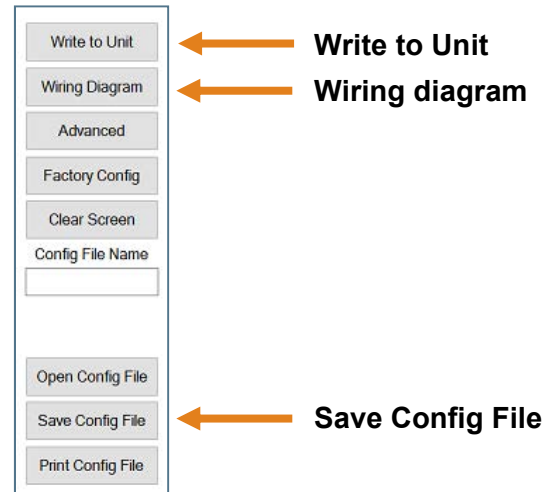

Next, use the file management features to save your configuration by clicking **“Save Config File”** and print your wiring diagram by clicking **“Wiring Diagram.”**

**“Save Config File”** will save this configuration as a text file which can be loaded back into WebCal® by pressing the **“Open Config File”** button. It is good practice to save the configuration file for each different configuration with a unique name for easy identification. If using multiple sensors in identical applications, then use of a single configuration file is recommended.

**“Wiring Diagram”** will display a PDF file showing the unique wiring for the specific configuration created in WebCal®. The PDF can be printed or emailed. It is good practice to save the wiring diagram as a backup.

**FACTORY SETTINGS**

EchoPod®	Sensor Height	Fill-Height
UG03 Series	118.1" (300 cm)	110.1" (279.7 cm)
UG01 Series	59.1" (150 cm)	55.1" (139.8 cm)

**USER SETTINGS**

Fill out the chart below and keep as a record of your configuration.

*Tank*

Height =	Fill-H =
----------	----------

*Units*

Inches	Feet	cm	Meter
--------	------	----	-------

*Display*

Air	Liquid
-----	--------

*Safe*

22mA	21 mA	20mA	Hold Last	4mA
------	-------	------	-----------	-----

*Rev mA*

4mA @ Bottom	4mA at Top
--------------	------------

*Start-up*

4mA	12mA	20mA	22mA
-----	------	------	------

*Relay(s)*

	Relay 1 (Blue)	Relay 2 (Orange)	Relay 3 (Yellow)	Relay 4 (Purple)
ON				
OFF				

TROUBLESHOOTING

PROBLEM	SOLUTION
Transmitter indicates a current of 0 mA:	Check the wiring for an open circuit. An open circuit is the most common issue with a 0 mA signal.
Transmitter jumps to a current reading between 19 and 20 mA:	Check the installation of the transmitter. Bad installation fittings will cause false signals near the top of the tank, which typically translates to a signal between 19 and 20 mA. Also look for interference just below the transmitter. If the transmitter is installed in a metal fitting, switch to a plastic fitting.
Transmitter indicates a current over 23 mA:	Immediately check the wiring for a short circuit. The EchoPod® is current limited to 22 mA. Anything above 23 mA indicates a short circuit.
Transmitter always jumps to the LOST condition.	Check the dimensional configuration ( <b>Sensor Height</b> and <b>Fill Height</b> ) of EchoPod®. Make sure that the <b>Fill-H</b> setting corresponds to the full level of liquid (measured from the bottom up) and not the distance from the transmitter to the liquid (top down).
Transmitter output is opposite of the level of liquid.	Check the <b>Output at Empty</b> Setting in WebCal®.
No Unit Detected in WebCal®.	If WebCal® cannot detect EchoPod® when connected to the computer: <ul style="list-style-type: none"> <li>• Check that the LI99-2001 Fob is connected to the USB® port.</li> <li>• Check that all four wires (Red, Black, White and Green) are securely attached to the Fob.</li> <li>• Check Device Manager and confirm that both drivers (WebCal® Configuration &amp; EchoFob) are present.</li> <li>• If the above do not work, reinstall the WebCal® software while the computer is in Safe Mode.</li> </ul>
Internet error. The server name or address could not be resolved.	This is a warning indicating that the computer configuring EchoPod® is not connected to the Internet. Click <b>OK</b> to continue. Flowline recommends being connecting to the Internet during configuration. But, not being connected to the Internet will not prevent EchoPod® from being configured.
Cannot access some of the configuration features in WebCal®.	As choices are made in Configuration, WebCal® will begin to eliminate functions that are not applicable to a configuration. To reset Configuration or get access to all the features, click on the <b>Clear Screen</b> button.
Relay closes, but does not open again.	An inductive kick may be holding the relay closed. If switching 24 VDC, make sure a diode has been installed to act as a snubber (see Step Nine). <b>Note:</b> <i>EchoPod® uses latching relays. When power is removed to the sensor, the relays will remain in their last state. Ex: If the relay is energized, when power is removed, the relay will remain in an energized state.</i>
Relay chatters on and off repeatedly.	Most likely the turbulence in the tank is causing the chatter. Increase the Hysteresis setting in WebCal® to eliminate the chatter.

### WARRANTY

Flowline warrants to the original purchaser of its products that such products will be free from defects in material and workmanship under normal use and service in accordance with instructions furnished by Flowline for a period of two years from the date of manufacture of such products. Flowline's obligation under this warranty is solely and exclusively limited to the repair or replacement, at Flowline's option, of the products or components, which Flowline's examination determines to its satisfaction to be defective in material or workmanship within the warranty period. Flowline must be notified pursuant to the instructions below of any claim under this warranty within thirty (30) days of any claimed lack of conformity of the product. Any product repaired under this warranty will be warranted only for the remainder of the original warranty period. Any product provided as a replacement under this warranty will be warranted for the full two years from the date of manufacture.

### RETURNS

Products cannot be returned to Flowline without Flowline's prior authorization. To return a product that is thought to be defective, go to [flowline.com](http://flowline.com), and submit a customer return (MRA) request form and follow the instructions therein. All warranty and non-warranty product returns to Flowline must be shipped prepaid and insured. Flowline will not be responsible for any products lost or damaged in shipment.

### LIMITATIONS

This warranty does not apply to products which: 1) are beyond the warranty period or are products for which the original purchaser does not follow the warranty procedures outlined above; 2) have been subjected to electrical, mechanical or chemical damage due to improper, accidental or negligent use; 3) have been modified or altered; 4) anyone other than service personnel authorized by Flowline have attempted to repair; 5) have been involved in accidents or natural disasters; or 6) are damaged during return shipment to Flowline. Flowline reserves the right to unilaterally waive this warranty and dispose of any product returned to Flowline where: 1) there is evidence of a potentially hazardous material present with the product; or 2) the product has remained unclaimed at Flowline for more than 30 days after Flowline has dutifully requested disposition. This warranty contains the sole express warranty made by Flowline in connection with its products. **ALL IMPLIED WARRANTIES, INCLUDING WITHOUT LIMITATION, THE WARRANTIES OF MERCHANTABILITY AND FITNESS FOR A PARTICULAR PURPOSE, ARE EXPRESSLY DISCLAIMED.** The remedies of repair or replacement as stated above are the exclusive remedies for the breach of this warranty. **IN NO EVENT SHALL FLOWLINE BE LIABLE FOR ANY INCIDENTAL OR CONSEQUENTIAL DAMAGES OF ANY KIND INCLUDING PERSONAL OR REAL PROPERTY OR FOR INJURY TO ANY PERSON. THIS WARRANTY CONSTITUTES THE FINAL, COMPLETE AND EXCLUSIVE STATEMENT OF WARRANTY TERMS AND NO PERSON IS AUTHORIZED TO MAKE ANY OTHER WARRANTIES OR REPRESENTATIONS ON BEHALF OF FLOWLINE.** This warranty will be interpreted pursuant to the laws of the State of California. If any portion of this warranty is held to be invalid or unenforceable for any reason, such finding will not invalidate any other provision of this warranty.

For complete product documentation, video training, and technical support, go to [flowline.com](http://flowline.com). For phone support, call 562-598-3015 from 8am to 5pm PST, Mon - Fri. (Please make sure you have the Part and Serial number available.)