

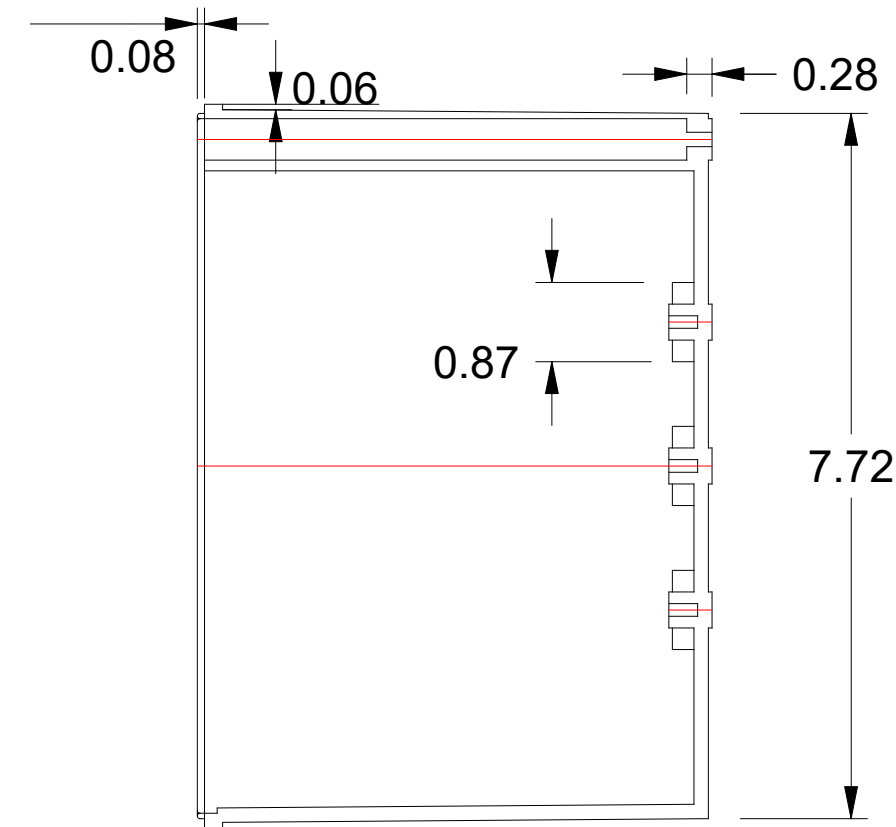

SCIGATE AUTOMATION (S) PTE LTD

No.1 Bukit Batok Street 22 #01-01 Singapore 659592
 Tel: (65) 6561 0488 Fax: (65) 6562 0588
 Email: sales@scigate.com.sg Web: www.scigate.com.sg
 Business Hours: Monday - Friday 8.30am - 6.15pm

BODY

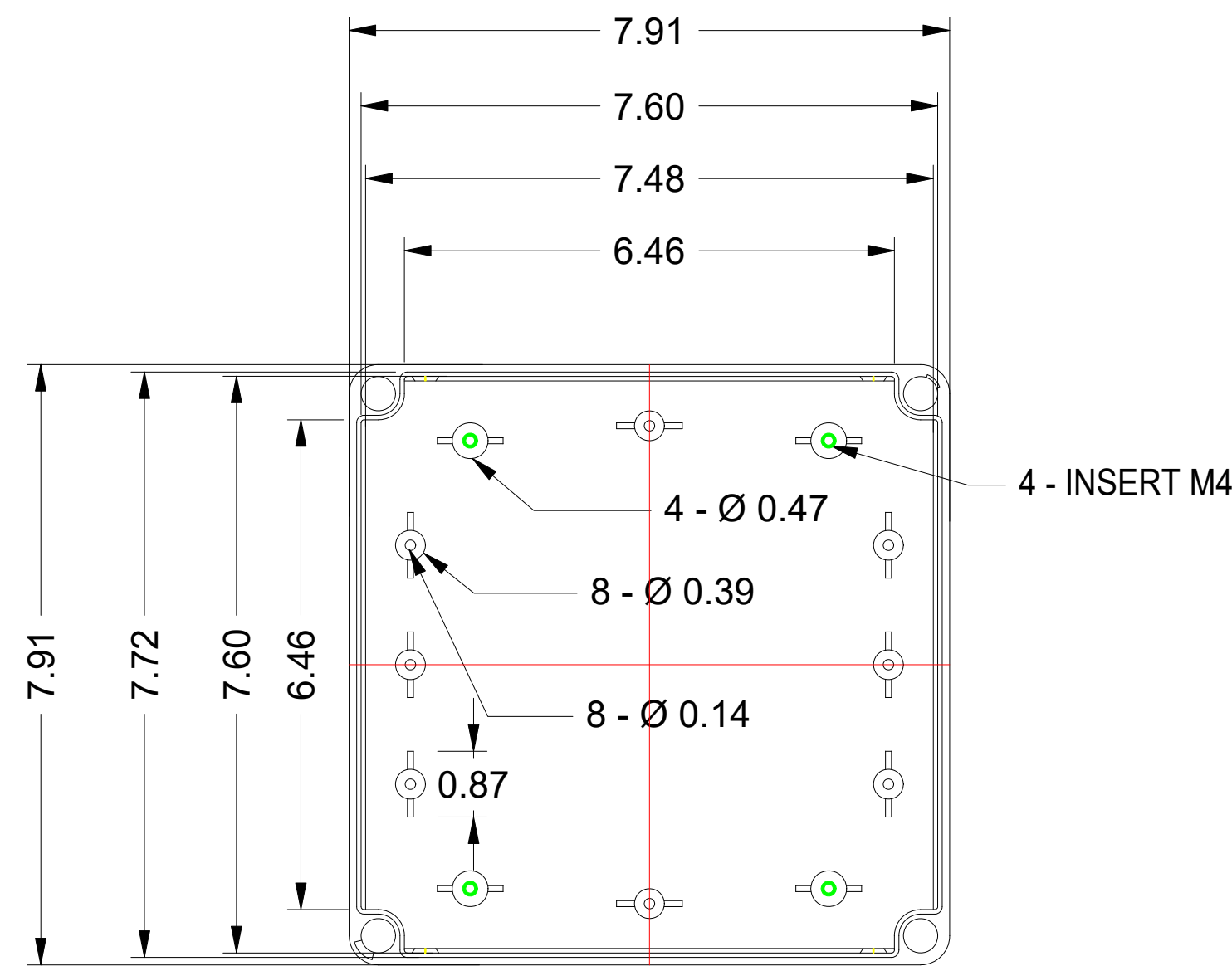

COVER

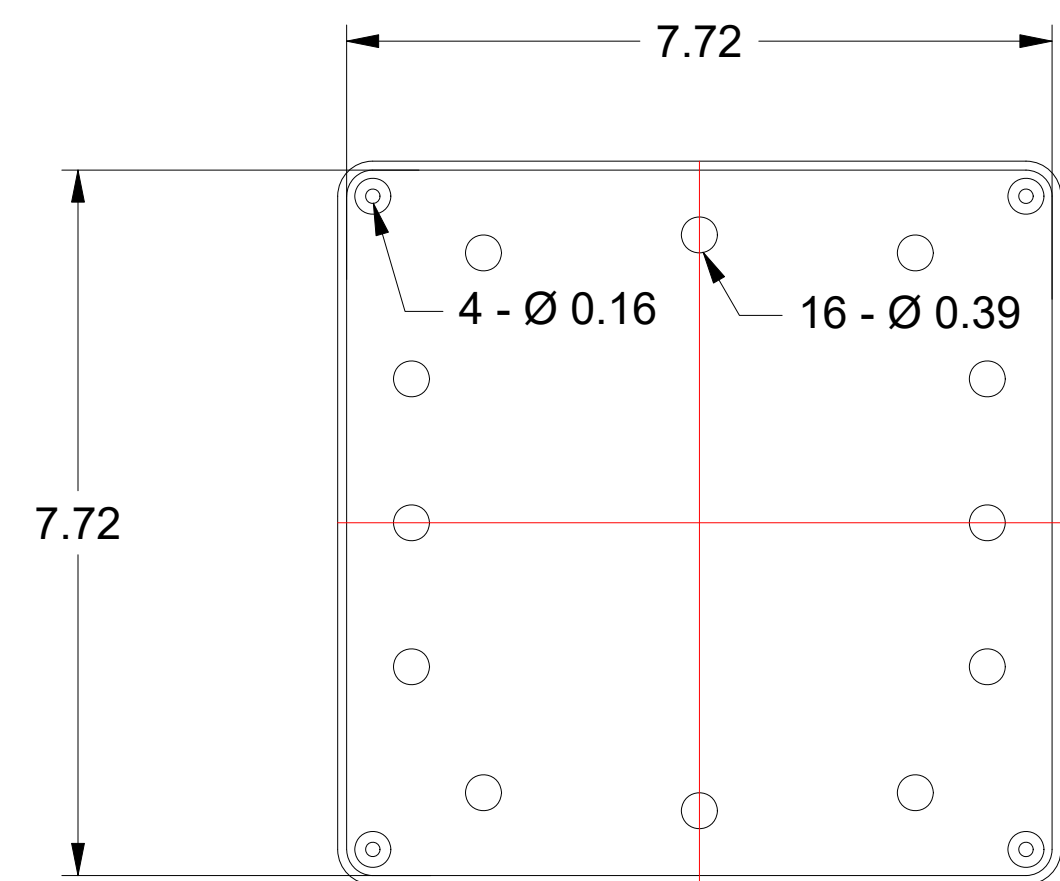
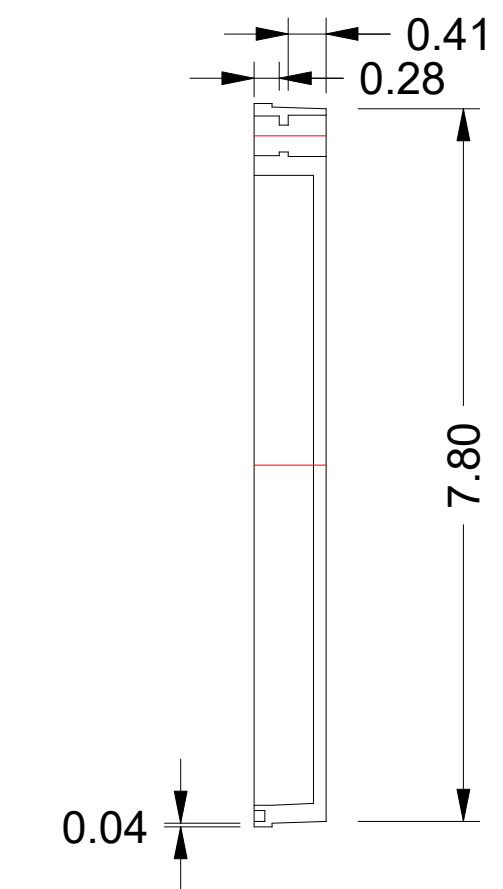
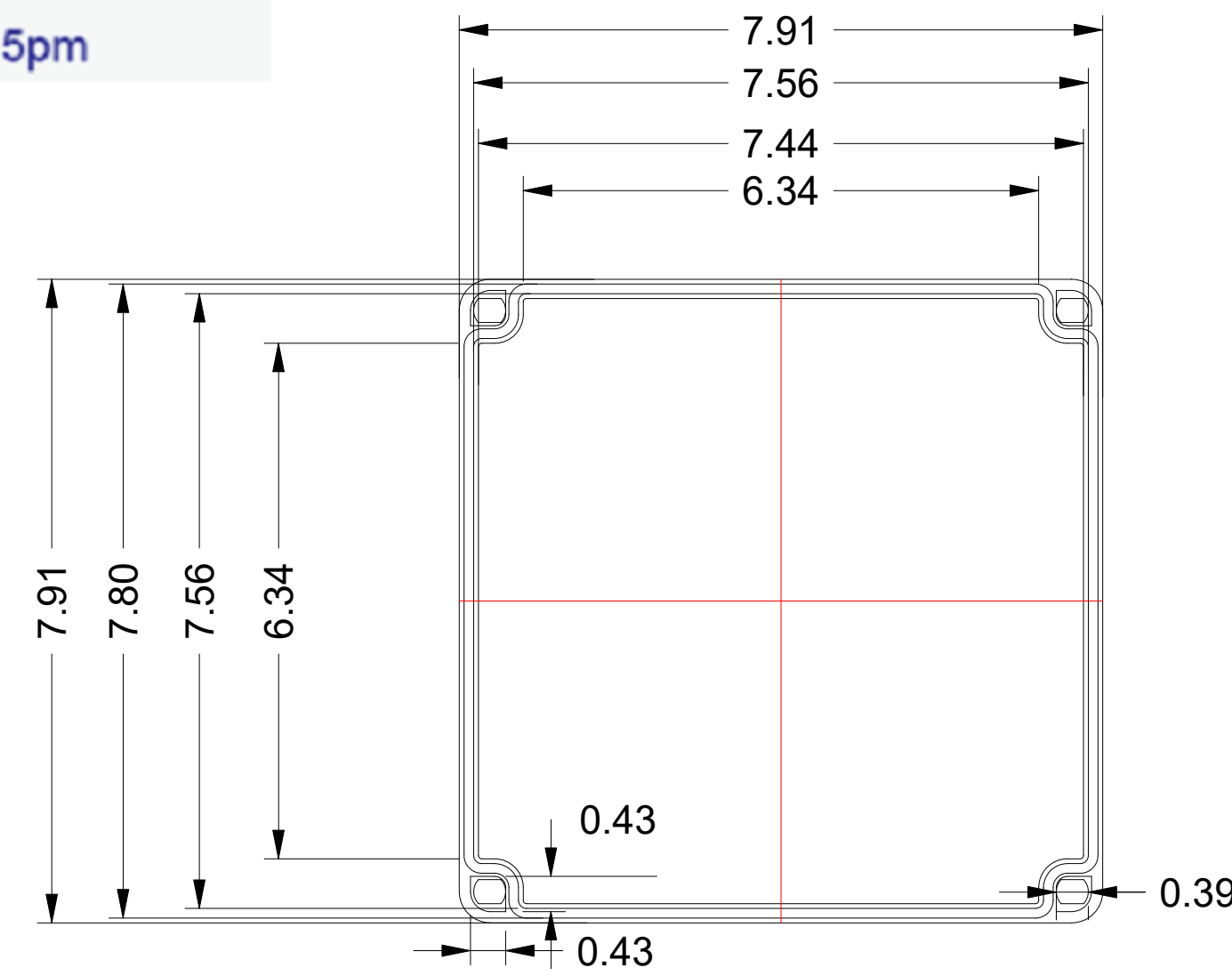

BOTTOM VIEW

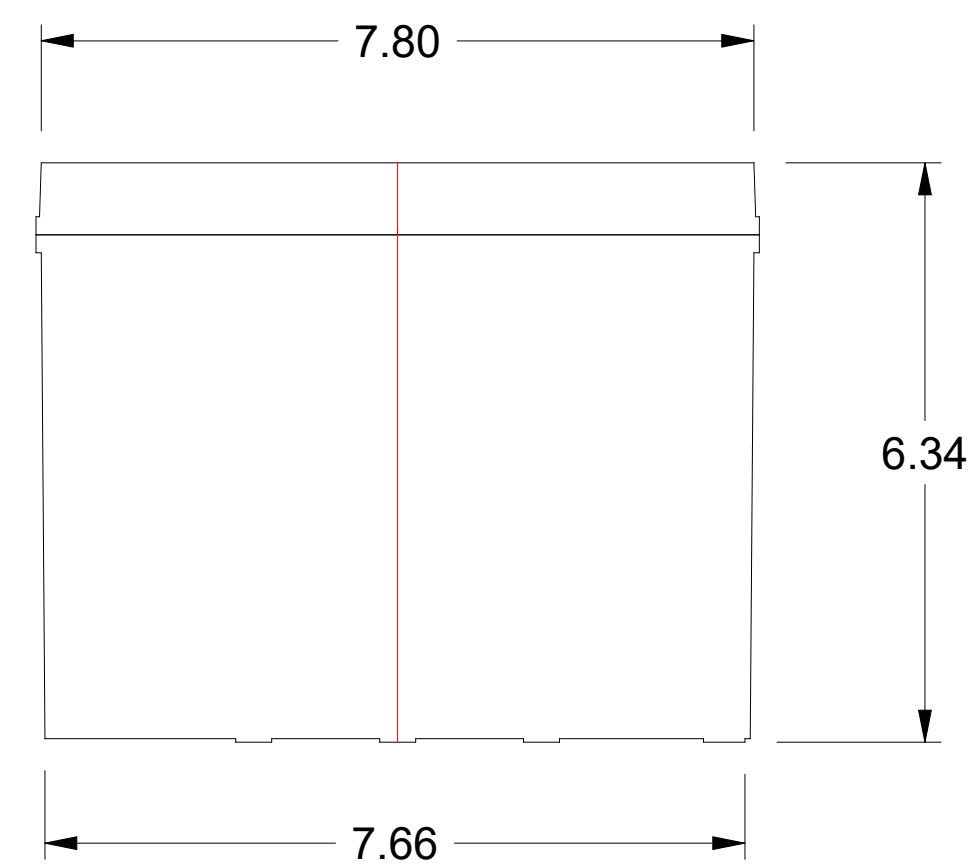

ASSEMBLED SIDE VIEW

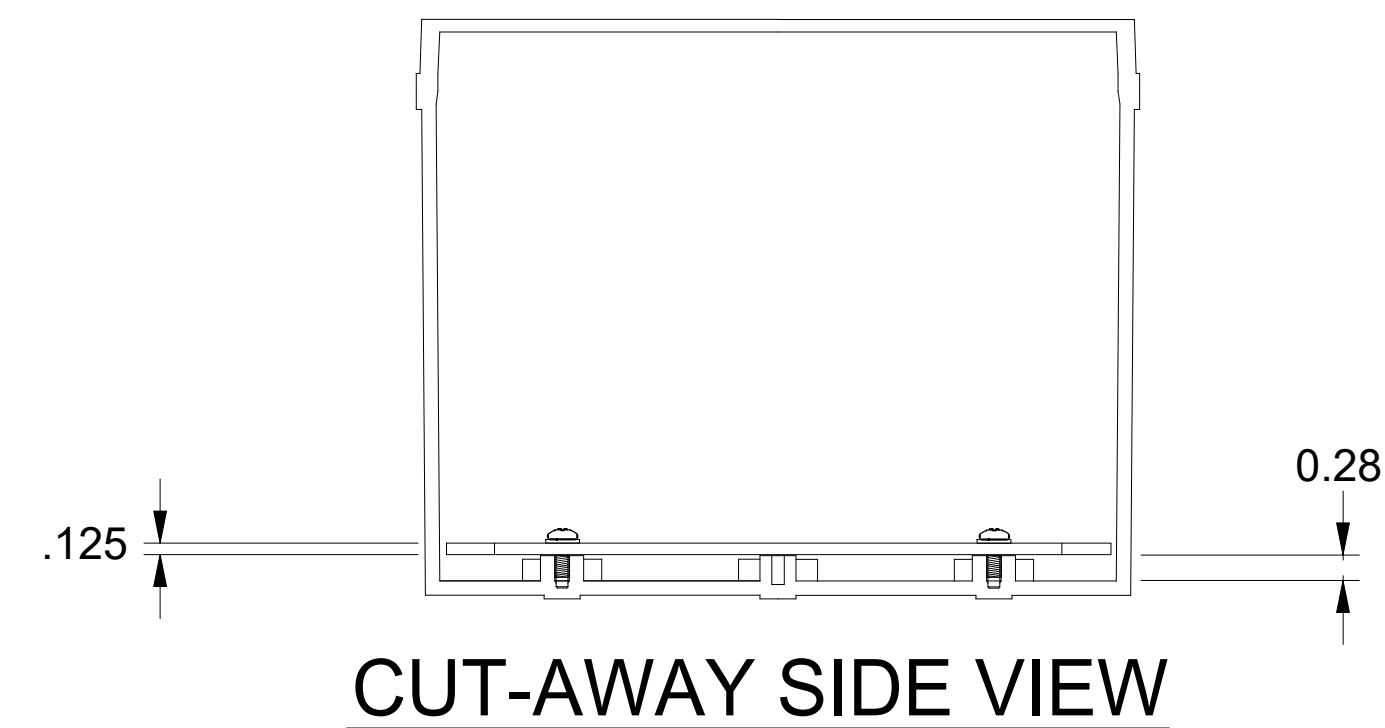

HARDWARE

- #8-32 1/2" PHILLIPS
- #8 WASHER

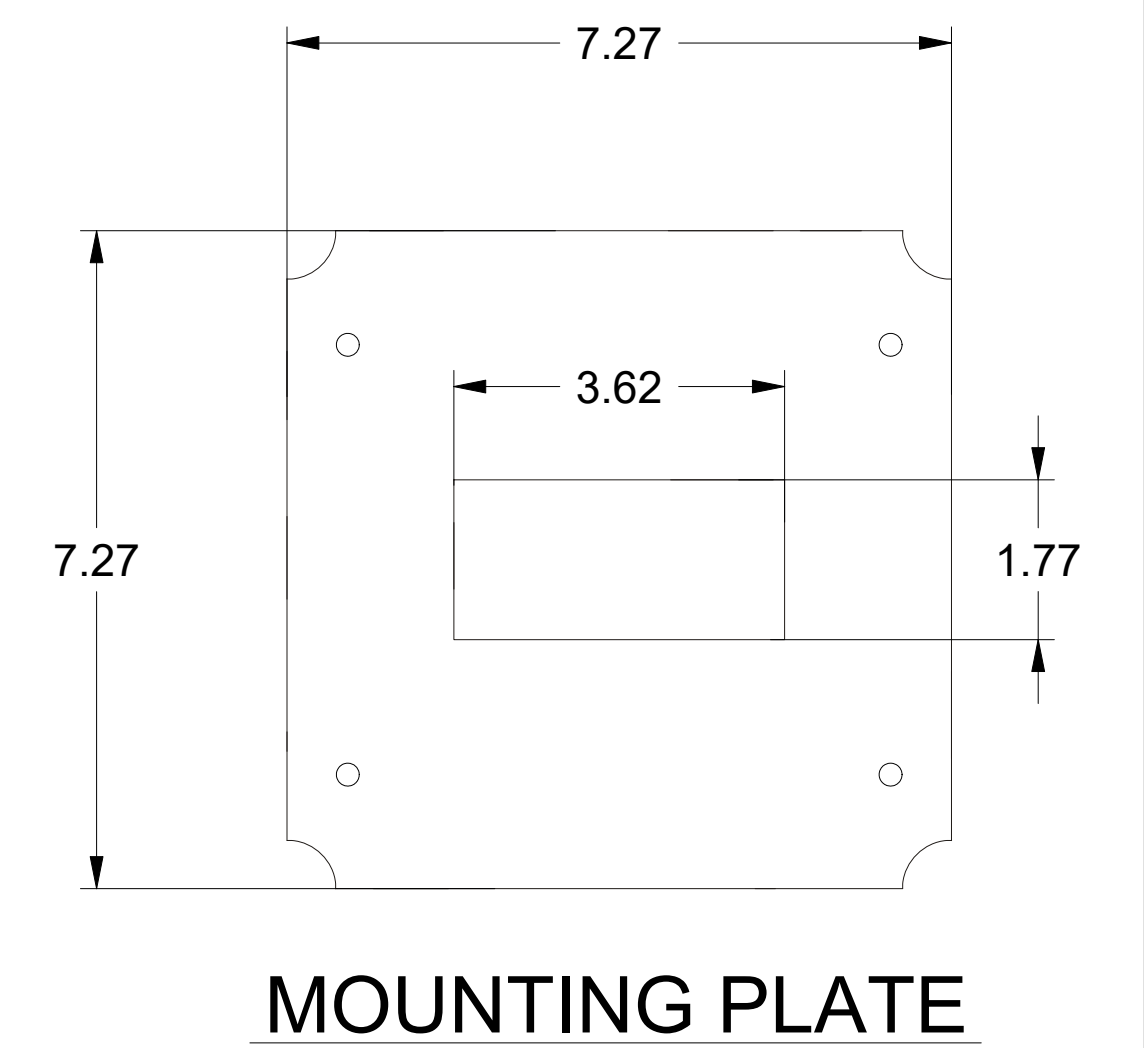

FLOWLINE INC.

LOS ALAMITOS, CA 90720

**LM92-1202 ENCLOSURE
DRAWING FILE
301685 REV A**

DRAWN
P. Colin
02/01/2016

NOTES: ALL DIMENSIONS SHOWN ARE IN INCHES.