

Rugged Tablet PC 7"

M9020B

Product Features:

- 7" High Quality 1024 x 600 Resolution LED Panel
- Intel® BayTrail-M N2930 1.83GHz Processor (up to 2.16GHz)
- 1 x 4GB DDR3L-1600 SO-DIMM RAM (up to 8GB)
- Meet MIL-STD-810G Shock, Vibration and Drop Standard
- Built-in 802.11 ac/a/b/g/n WiFi + Bluetooth 4.0 (Class II) combo module
- 6200 mAh Li-ion Battery, 7.4V
- Short range barcode 1D/2D(Optional)
- Full QWERTY Keyboard (5 programmable function keys)



Main Unit



Docking (Optional)

Product Specifications:

System Specification	Processor	Intel® BayTrail-M N2930 1.83GHz Processor (up to 2.16GHz)
	System Memory	1 x 4GB DDR3L-1600 SO-DIMM RAM (up to 8GB)
	Storage	64GB mSATA SSD (upgradable to 512GB)
	Operating System	Windows Embedded 8.1 Industry Pro 64bit (Support Desktop Mode)
Display Specification	Size	7"
	Resolution	1024 * 600
	Brightness	900nit (typ.)
	Touch	4W Resistive Touch (GFG)
	Sensors	Light sensor for auto backlight adjustment Position sensor (accelerometer) for portrait or landscape screen orientation
Wireless Communication	Wireless and Bluetooth	802.11 ac/a/b/g/n WiFi + Bluetooth 4.0 (Class II) combo module
	WWAN	Optional LTE (Sierra MC7304 or MC7354)
	GPS	Built-in Neo-6 GPS module
Mechanical and Environment	Dimensions (W x L x H)	229.75 x 183 x 54 mm (Standard)
	Weight	1.43 kg
	Operation Temperature	-20°C to 60°C (AC mode), -20°C to 50°C (Battery mode)
	Operation Humidity	5~95% RH (non condensing)
	IP Proof	IP67
I/O Connectors	External I/O	1 x USB 2.0 A Type, 1 x RS232 1 x Headset jack 1 x 2.5Ø DC Power Input 1 x Micro SD card slot (up to 32GB)
	Expansion Ports (Pin Headers for I/O Customization)	4 x USB 2.0 1 x power output 5V 2A 1 x SVGA 4 x RS-232
Power Management	Power input	19V DC in
Field Service Features	Adapter	65W
	Camera	2M pixel camera front side; 5M rear camera with autofocus and flash light
	Barcode (optional)	2D barcode scanner (Reads 1D and 2D barcodes)
	UHF RFID (optional)	UHF-RFID standard support



SCIGATE AUTOMATION (S) PTE LTD

No.1 Bukit Batok Street 22 #01-01 Singapore 659592
 Tel: (65) 6561 0488 Fax: (65) 6562 0588
 Email: sales@scigate.com.sg Web: www.scigate.com.sg
 Business Hours: Monday - Friday 8.30am - 6.15pm

*Note: this is a simplified drawing and some components are not marked in detail. Please contact our sales representative if you need further product information.

Dimensions (Main unit with docking) :



SCIGATE AUTOMATION (S) PTE LTD

No.1 Bukit Batok Street 22 #01-01 Singapore 659592
 Tel: (65) 6561 0488 Fax: (65) 6562 0588
 Email: sales@scigate.com.sg Web: www.scigate.com.sg
 Business Hours: Monday - Friday 8.30am - 6.15pm

Accessories
1. 19V 65W Power Adapter x 1
2. Power Cord x 1
3. Standard Battery x 2
4. M9020B Quick Start Guide x 1
5. Manual & Driver CD x 1
6. Stylus Pen x1
7. Hand Strap

Order Information	
M9020B	Basic
M9020B-LE	4G/LTE for Europe
M9020B-LA	4G/LTE for North America

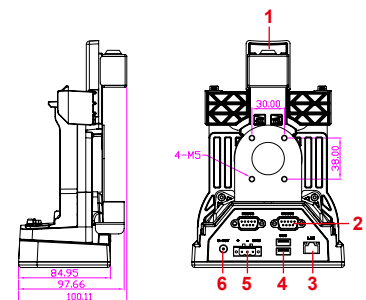
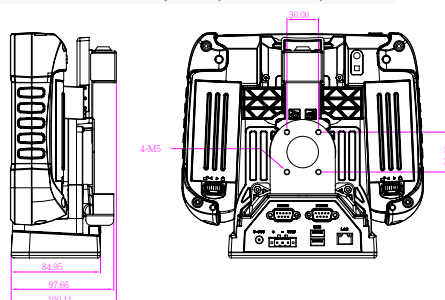
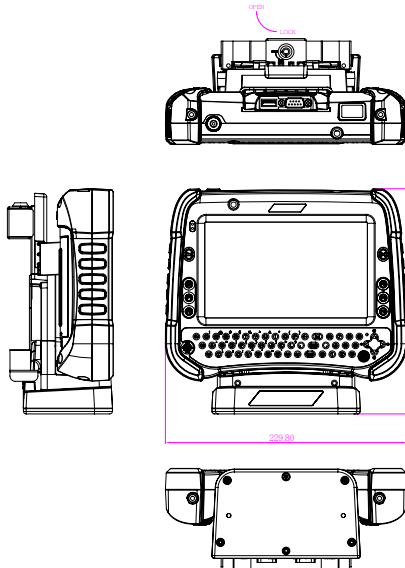

1. Lock
2. RS-232 Connectors
3. RJ-45 Connector
4. USB Ports
5. Bare leads DC connector
6. Power Connector