

Sensor Identification:

Form to be returned to: sales-de@stssensors.com

Brand:	Type:	Max. outer diameter of sensor: see picture: 4 / 5 / 6
<input type="text"/>	<input type="text"/>	<input type="text"/>
Tank name:	Cable length:	Range [mbar] at 20 mA:
<input type="text"/>	<input type="text"/>	<input type="text"/>
Output signal:	Flange size DN: see picture: 1 / 2 / 3	Screw connection: see picture: 1 / 2 / 3 / 4
<input type="text" value="4 - 20 mA"/>	<input type="text"/>	<input type="checkbox"/> male <input type="checkbox"/> female

Measurement type:

- Relative
 Absolute
 PT100

Side mounted (dry)

Top mounted (submerged)

- Picture 1:
with flange and ball valve

- Picture 2:
with flange

- Picture 5:
with top flange and clamp

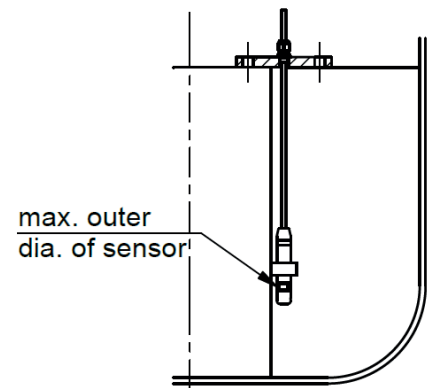
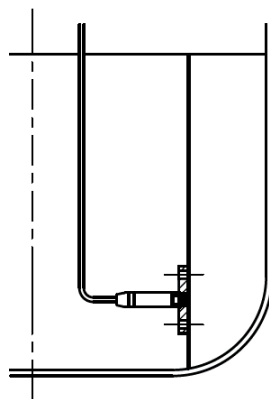
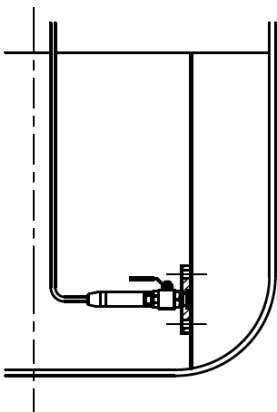

- Picture 3:
with welding block and ball valve

- Picture 4

- Picture 6:
with top flange and guide tube

