



SCIGATE AUTOMATION (S) PTE LTD

Bukit Batok Street 22 #01-01 Singapore 659592

Tel: (65) 6561 0488

Fax: (65) 6561 0588

Email: sales@scigate.com.sg

Web: <https://scigate.com.sg/>

Business Hours: Monday - Friday 8:30AM - 6:15PM

More Precision

thermoMETER // Non-contact infrared temperature sensors





thermoMETER CTex

Measurement system for use in EX areas

- Low cost solution due to easy concept
- Sensor as passive element can be easily used in Ex areas
- Energy limitation via Zener barriers from STAHL

Zener barriers

The Zener double barriers from type 9002/22-032-300-111 are included in the scope of supply.

Note: The functionality and the compliance with the factory calibration are only ensured with use of the recommended Zener barriers.

Optical specifications thermoMETER CT

□ =smallest spot size / focal point (mm)

Standard Focus																
SF02	2:1	5	53.8	102.5	151.3	200	251.3	302.5	353.8	405						
	distance in mm	0	100	200	300	400	500	600	700	800						
SF15	15:1	6.5	10.3	14.1	17.9	21.7	25.4	30.9	37.1	43.3	49.5	55.8	62	68.2	74.4	80.7
	distance in mm	0	75	150	225	300	375	450	525	600	675	750	825	900	975	1050
SF22	22:1	6.5	10.9	15.2	19.5	23.9	28.3	32.6	37	41.3	45.7	50				
	distance in mm	0	110	220	330	440	550	660	770	880	990	1100				
Close Focus (with optionally available CF lens)																
CF02	2:1	5	3.9	2.8	2.5	4.8	6.4	8	11.3	14.6						
	distance in mm	0	10	20	23	30	35	40	50	60						
CF15	15:1	6.5	3.7	0.8	4.4	8.1	11.8	15.4	19.1	22.7						
CF22	22:1	7	3.8	0.6	4.4	8.2	12	15.8	19.6	23.4						
	distance in mm	0	5	10	15	20	25	30	35	40						

Technical details of the Zener barriers ¹ Type 9002/22-032-300-111			
Certifications	Europe (CENELEC)	for Zone 1: PTB 01 ATEX 2053 for Zone 2: PTB 01 ATEX 2054	
	USA	FM Approval 3010778	
	Canada	CSA 1284580 (LR 43394)	
	Europe (CENELEC)	for Zone 1: E-II (1/2) G [EEx ia/ib] IIC/IIB for Zone 2: E II 3 G EEx nA II T4	
Explosion protection	USA	I.S. circuits for: Class I, II, III, Division 1, Groups A, B, C, D, E, F, G Class I, Zone 0, Group IIC Class I, Division 2, Groups A, B, C, D Class I, Zone 2, Group IIC	
		Canada	I.S. circuits for: Class I, Groups A, B, C, D; Class II, Groups E, F, G Class III Class I, Division 2, Groups A, B, C, D Class I, Zone 2, Groups IIC
			Installation
	Protection class		according to IEC 60529/clamping carrier IP20/housing IP40
	Ambient temperature	-20 °C to 60 °C	
	Technical data	Temperature measurement thermoMETER CT - controller/sensor - see page 22-23	

¹ Source: company R. STAHL AG

We reserve the right to make changes due to further technical developments.

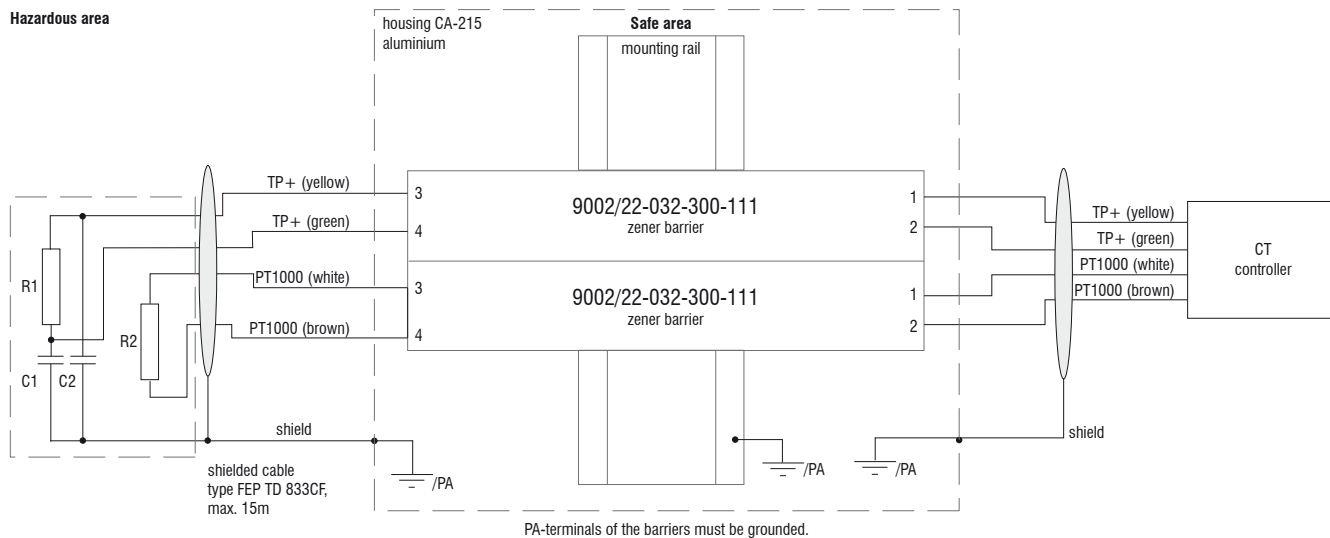

Sensor: "simple electrical device" (according to EN 60079-11)

Scope of supply

- Alu housing with mounted Zener barrier (mounting rail) and CT controller
- Pre-assembled connection cable for CT controller
- Software tool for calibration of barrier resistance in the sensor code

CT / CTfast / CTM1/M2/M3

controller

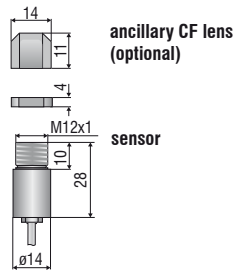
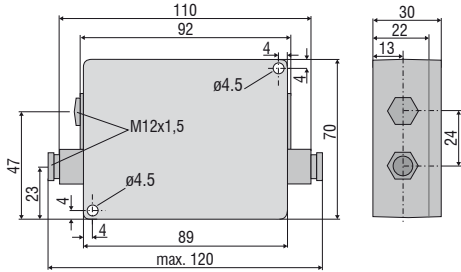

CThot / CTP-3 / CTP-7

controller

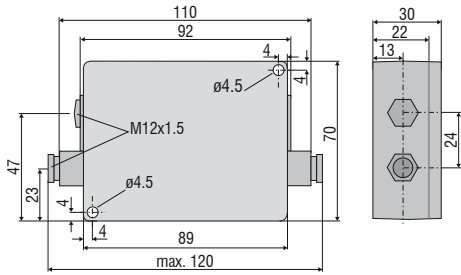

sensor with protective housing

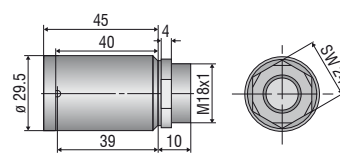

CTM3-XL

controller

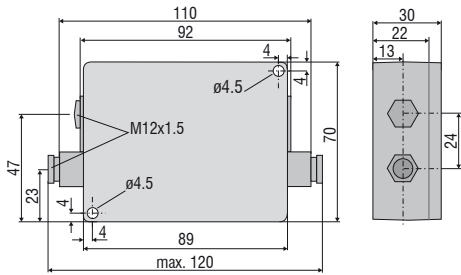

sensor

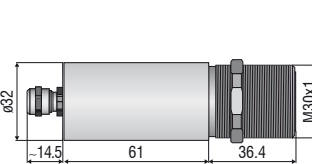

CTex

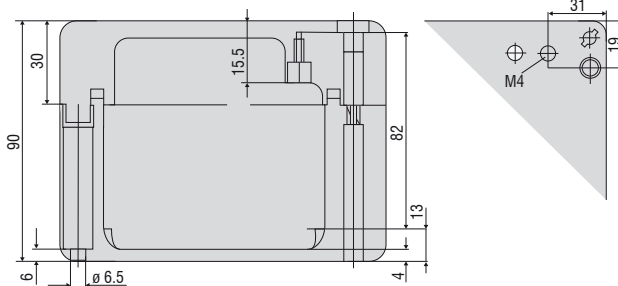
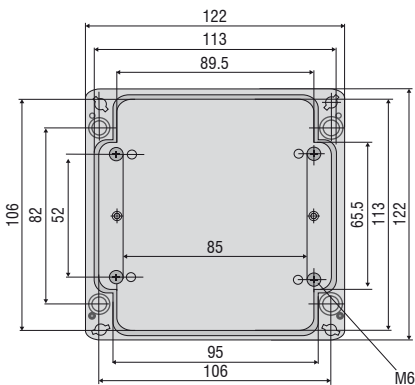

Mechanical accessories		
Art. No.	Model	
2970203	TM-FB-CT	Mounting bracket, fixed
2970325	TM-FB2-CT	Mounting bracket, adjustable in one axis, for simultaneous assembly of CT sensor and laser sighting aid
2970336	TM-FBMH-CT	Mounting bracket, adjustable in one axis, for massive housing
2970204	TM-AB-CT	Mounting bracket, adjustable in 2 axes
2970205	TM-MB-CT	Mounting bolts with M12x1 thread
2970206	TM-MG-CT	Mounting fork, adjustable in 2 axes, with M12x1 fastening
2970207	TM-AP-CT	Air purge collar for sensors from 10:1 lens
2970335	TM-APS-CT	Air purge collar for sensors from 10:1 lens made from stainless steel
2970208	TM-AP2-CT	Air purge collar for sensor with 2:1 lens
2970209	TM-APL-CT	Air purge collar, laminar
2970210	TM-APLCF-CT	Air purge collar, laminar with integrated ancillary CF lens
2970357	TM-APLCFH-CT	Air purge collar, laminar with integrated ancillary CF lens for M1/M2/M3/M5 sensors
2970386	TM-APMH-CT	Air purge collar made from stainless steel for massive housing
2970211	TM-RAM-CT	Right angle mirror for measurements 90 °C to the sensor axis
2970212	TM-RAIL-CT	Rail mount adapter for CT controller
2970213	TM-COV-CT	Closed cover for controller
2970214	TM-MHS-CT	Massive housing made from stainless steel
2970215	TM-MHSCF-CT	Massive housing made from stainless steel with integrated ancillary CF lens
2970358	TM-MHSCFH-CT	Massive housing made from stainless steel with integrated ancillary CF lens for M1/M2/M3/M5 sensors
2970216	TM-MHA-CT	Massive housing made from anodized aluminum
2970217	TM-MHACF-CT	Massive housing made from stainless steel with integrated ancillary CF lens
2970359	TM-MHACFH-CT	Massive housing made from anodized aluminum with integrated ancillary CF lens for M1/M2/M3/M5 sensors
2970218	TM-MHB-CT	Massive housing made from brass
2970219	TM-MHBCF-CT	Massive housing made from brass with integrated ancillary CF lens
2970360	TM-MHBCFH-CT	Massive housing made from brass with integrated ancillary CF lens for M1/M2/M3/M5 sensors
2970220	TM-PT-CT	Protective tube made from brass
2970326	TM-PA-CT	Pipe adapter for the mounting of reflection protection tubes
2970327	TM-ST20-CT	Reflection protection tube, length 20 mm
2970328	TM-ST40-CT	Reflection protection tube, length 40 mm
2970329	TM-ST88-CT	Reflection protection tube, length 88 mm
2970221	TM-LST-CT	Laser sighting aid for CT sensors incl. batteries (2xAlkaline AA)
2970300	TM-LSTOEM-CT	OEM laser sighting aid, 635 nm, 3.5 m cable, for connection to CT controller
2970300.008	TM-LSTOEM-CT(008)	OEM laser sighting aid, 635 nm, 8 m cable, for connection to CT controller
2970222	TM-EX-CT	Accessories kit for using CT in Ex areas (Zone 1: PTB 01 ATEX 2053/ E II (1/2) G [EEx ia/ib] IIC/ IIB), pre-assembled EX box, without Zener barriers, applicable in combination with CT sensors (except for CTfast)

Optical accessories		
Art. No.	Model	
2970201	TM-CF-CT	Ancillary CF lens (only for SF models)
2970202	TM-PW-CT	Protective window (only for SF models)
2970297	TM-CFAG-CT	Ancillary lens with external thread
2970330	TM-CFH-CT	Ancillary lens for M1/M2/M3/M5 sensors
2970331	TM-CFHAG-CT	Ancillary lens with external thread for M1/M2/M3/M5 sensors
2970299	TM-PWAG-CT	Protective window with external thread
2970332	TM-PWH-CT	Protective window for M1/M2/M3/M5 sensors
2970333	TM-PWHAG-CT	Protective window with external thread for M1/M2/M3/M5 sensors

Interfaces		
Art. No.	Model	
2970223	TM-USBK-CT	USB interface kit: USB interface, USB cable, CompactConnect software, second cable gland for controller
2970224	TM-RS232K-CT	RS232 interface: RS232 interface, computer cable, CompactConnect software, second cable gland for controller
2970338	TM-RS485USBK-CTL	RS485-USB-adapter, incl. PC cable, CompactConnect software and CTmulti, second cable gland for use with interface board TM-RS485B-CT
2970226	TM-RS485B-CT	RS485 interface board incl. second cable gland
2970227	TM-CANK-CT	CAN-Bus interface for thermoMETER CT/ protocol: CANopen presets: module address 20 (14H), 250 kBaud, 0-60 °C
2970228	TM-PFBDPK-CT	Profibus-DPV1 interface for thermoMETER CT with plug-in connection
2970229	TM-ETHNK-CT	Ethernet-Kit: interface board, external Ethernet adapter, CompactConnect software, second cable gland
2970230	TM-RI-CT	Relay interface: two electrically isolated relays, 60 VDC/ 42 VAC _{eff} , 0.4 A

Calibration		
Art. No.	Model	
2970231	TM-CERT-CT	Certificate of calibration
2970310	TM-HTCERT-CT	Certificate of calibration for CTM sensors

CTM3-XL		
Art. No.	Model	
2970352	TM-FBXL-CT	Mounting bracket, adjustable in one axis
2970353	TM-ABXL-CT	Mounting bracket, adjustable in 2 axes
2970354	TM-APXL-CT	Air purge collar, stainless steel
2970361	TM-XLCERT-CT	Certificate of calibration



TM-FB-CT Mounting bracket, adjustable in one axis

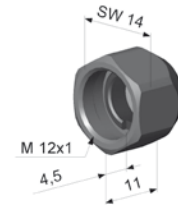
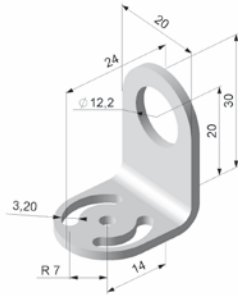

TM-CF-CT Ancillary CF lens (only for SF models)

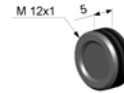

TM-CFAG-CT Ancillary CF lens with external thread
TM-PWAG-CT Protective window with external thread



TM-AB-CT Mounting bracket, adjustable in two axes

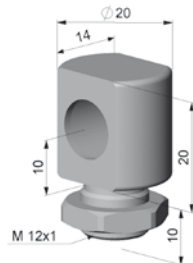

TM-MB-CT mounting bolt with M12x1 thread adjustable in one axis



TM-APL-CT Air purge collar, laminar and TM-MG-CT Mounting fork

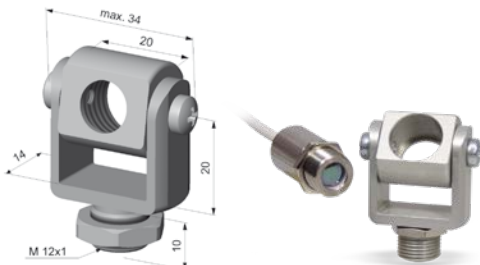

TM-MG-CT Mounting fork with M12x1 thread, adjustable in two axes

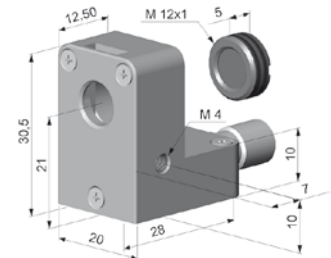

TM-APLCF-CT Ancillary CF lens/protective window - integrable variant for laminar air purge collar

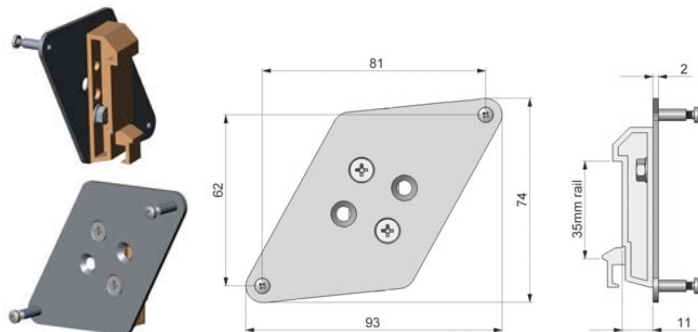

TM-RAIL-CT rail mount adapter for controller

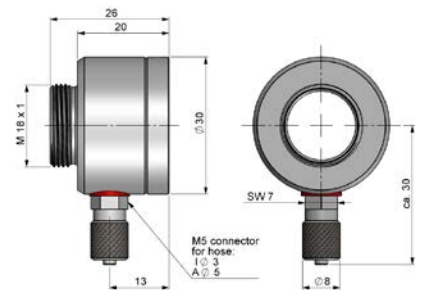

TM-APMH-CT Air purge collar made from stainless steel for massive housing



TM-PA-CT Pipe adapter for reflection protection tube

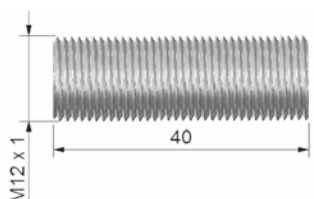
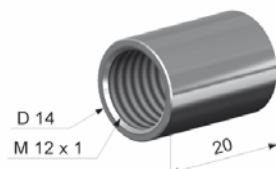

TM-ST40-CT Reflection protection tube



TM-LST-CT Laser sighting aid, battery-operated (2x Alkaline AA), for alignment of CT sensors (dimensions identical to CT sensor)

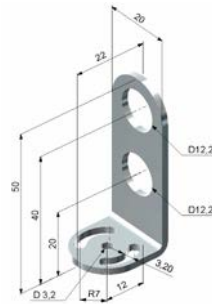

TM-FB2-CT Mounting bracket for sensor and laser sighting aid



TM-RAM-CT Right angle mirror



TM-MHS-CT Massive housing, stainless steel
 TM-MHA-CT Massive housing, aluminum
 TM-MHB-CT Massive housing, brass

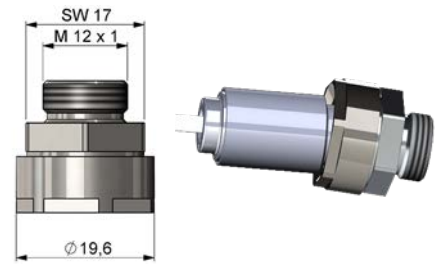
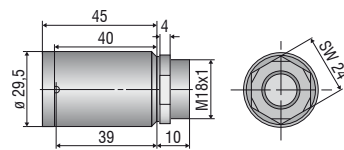

TM-TAS-CT Pivoted joint for CT sensors



Dirt and deposit on the lens like smoke, steam and high air humidity (condensation) are avoided or reduced by using an air purge collar.

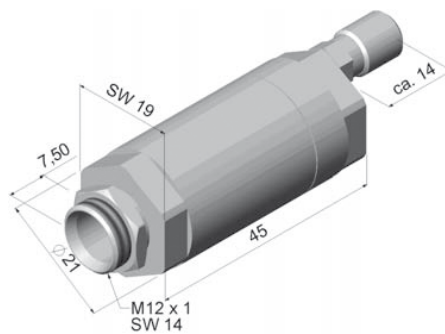

TM-AP-CT Standard air purge collar for 10:1 / 15:1 / 22:1 lenses
 TM-APS-CT Air purge collar, stainless steel

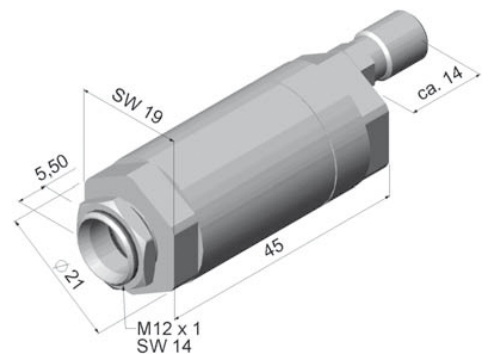

TM-AP2-CT Standard air purge collar for 2:1 lens

Further IR temperature measurement devices from Micro-Epsilon



thermoIMAGER TIM
Compact USB thermal imaging cameras
for precise thermography



thermoMETER CTVideo/CSVideo
Infrared temperature sensors with crosshair
laser sighting and video output



thermoMETER Handheld
Innovative handheld pyrometer with laser
sighting for inspection and maintenance