

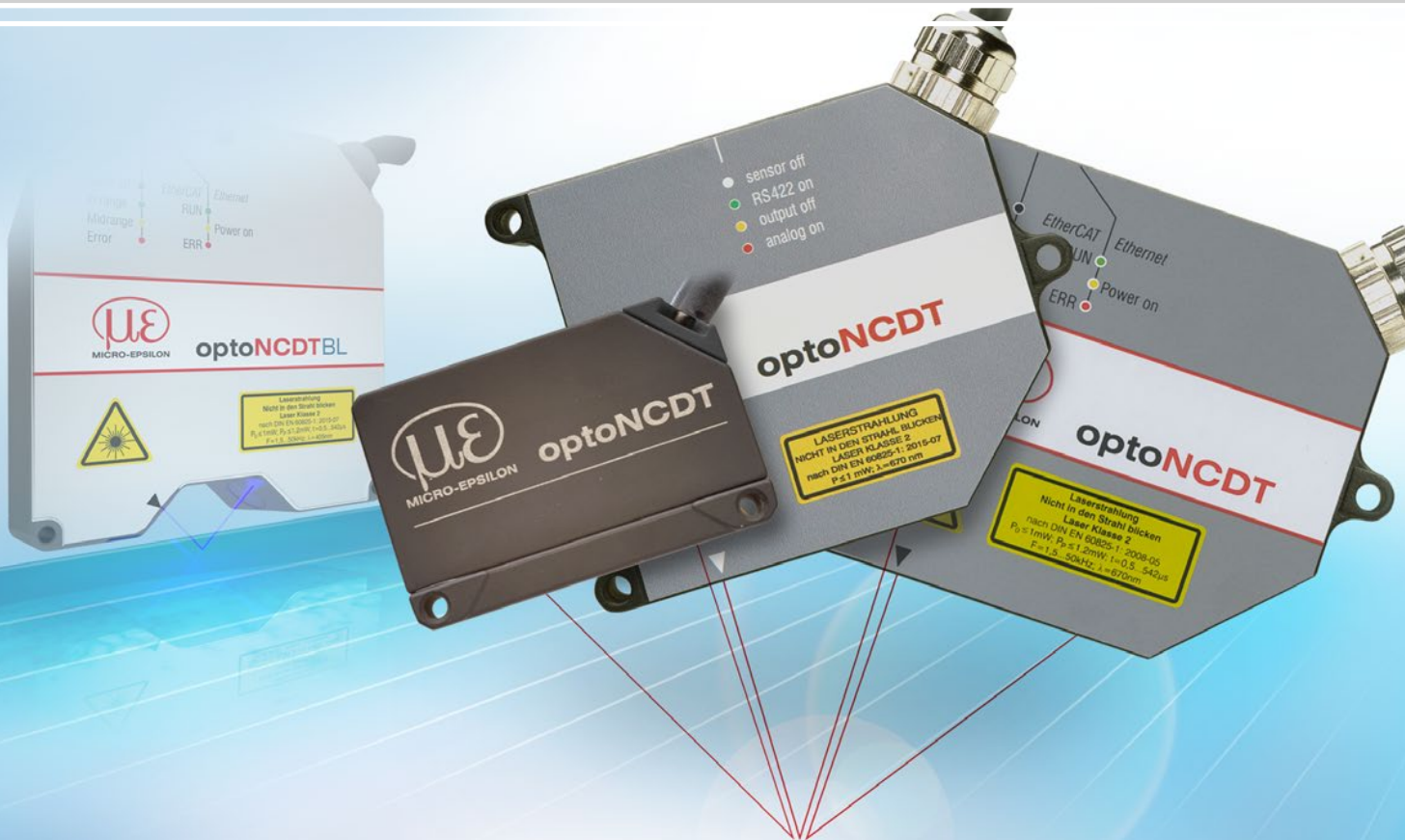







# More Precision

**optoNCDT** // Laser displacement sensors (triangulation)





-  **Blue Laser Technology**  
(Blue violet laser diode 405 nm)
-  **Adjustable measuring rate**  
up to 49.14 kHz
- INTER FACE**  
Analog (U/I) / RS422 / Ethernet / EtherCAT / PROFINET / EtherNet/IP
-  **Advanced Real-Time-Surface-Compensation**
-  **Measurement of diffuse and specular surfaces**
-  **Configuration via web interface**

optoNCDT 2300BL Blue Laser sensors are designed for fast and high resolution measurements of displacement, distance and position. The optoNCDT 2300 is the high performance version of Micro-Epsilon laser triangulation sensors and offers an adjustable measuring rate of up to 49.14 kHz. The entire electronics is integrated in a compact sensor which is a worldwide unique feature in this sensor class.

The Blue Laser Technology patented by Micro-Epsilon offers decisive advantages compared to red-diode laser sensors. Since the blue laser point does not penetrate the surface, the target is sharply imaged onto the sensor element. This makes it possible to achieve high resolution and reliable signal stability.

**optoNCDT 2300-2BL / 2300-5BL / 2300-10BL**  
Diffuse reflection

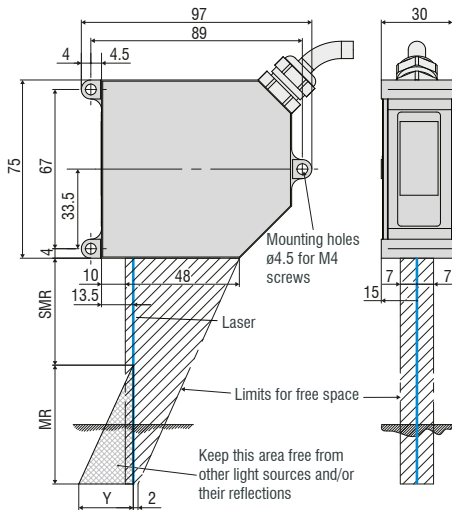

MR	SMR	Y
2	24	1.5
5	24	3.5
10	30	6.5

**optoNCDT 2300-2BL / 2300-5BL / 2300-10BL**  
Direct reflection

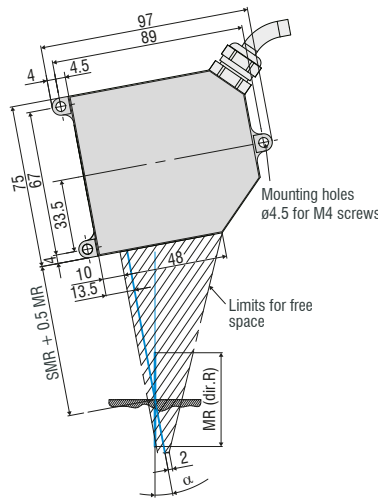

MR	SMR + 0.5 MR	α
2	25	20.5°
5	26.5	20°
10	35	17.5°

**optoNCDT 2310-50BL**

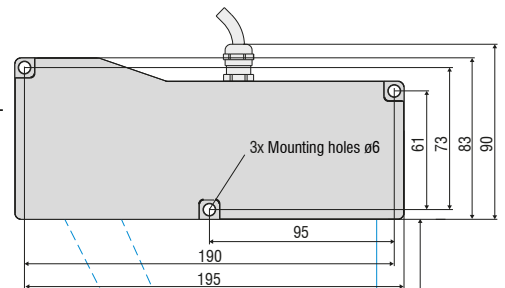
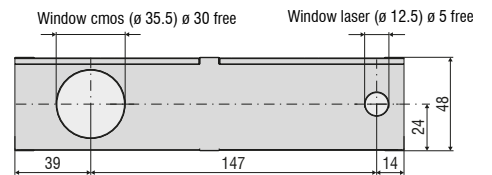

(Dimensions in mm, not to scale.)

**Connector (sensor side)**

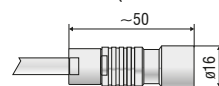

Model		ILD2300-2BL	ILD2300-5BL	ILD2300-10BL	ILD2310-50BL
Measuring range <sup>1)</sup>		2 (2) mm	5 (2) mm	10 (5) mm	50 (25) mm
Start of measuring range <sup>1)</sup>		24 (24) mm	24 (24) mm	30 (35) mm	550 (575) mm
Mid of measuring range <sup>1)</sup>		25 (25) mm	26.5 (25) mm	35 (37.5) mm	575 (587.5) mm
End of measuring range <sup>1)</sup>		26 (26) mm	29 (26) mm	40 (40) mm	600 (600) mm
Measuring rate		7 adjustable stages: 49.14 kHz <sup>2)</sup> / 30 kHz / 20 kHz / 10 kHz / 5 kHz / 2.5 kHz / 1.5 kHz			
Linearity		< ±0.6 μm	< ±1.5 μm	< ±2 μm	< ±40 μm
		< ±0.03 % FSO		< ±0.02 % FSO	< ±0.08 % FSO
Resolution <sup>3)</sup>		0.03 μm	0.08 μm	0.15 μm	7.5 μm
Light spot diameter (± 10 %)	SMR	70 x 80 μm	200 x 200 μm	75 x 85 μm	400 ... 500 μm
	MMR	20 x 20 μm	20 x 20 μm	32 x 45 μm	
	EMR	80 x 100 μm	200 x 400 μm	110 x 160 μm	
Light source		Semiconductor laser < 1 mW, 405 nm (blue violet)			
Laser safety class		Class 2 in accordance with DIN EN 60825-1: 2015-07			
Permissible ambient light		10,000 lx			
Supply voltage		11 ... 30 VDC			
Power consumption		< 3 W (24 V)			
Signal input		Laser on/off, sync in, trigger in			
Digital interface		RS422 (16 bit) / Ethernet / EtherCAT / PROFINET <sup>4)</sup> / EtherNet/IP <sup>4)</sup>			
Analog output <sup>4)</sup>		4 ... 20 mA / 0 ... 5 V / 0 ... 10 V / ±5 V / ±10 V			
Synchronization		possible for simultaneous or alternating measurements			
Connection		integrated pigtail 0.25 m with 14-pin cable connector, min. bending radius 30 mm (fixed installation); optional extension to 3 m / 6 m / 9 m possible (see accessories for suitable connection cable)			
Installation		Screw connection via three mounting holes			
Temperature range	Storage	-20 ... +70 °C (non-condensing)			
	Operation	0 ... +50 °C (non-condensing)			
Shock (DIN EN 60068-2-29)		15 g / 6 ms in 3 axes			
Vibration (DIN EN 60068-2-6)		2 g / 20 ... 500 Hz			
Protection class (DIN EN 60529)		IP65			
Material		Die-cast zinc housing			
Weight		approx. 550 g (incl. pigtail)		approx. 800 g (incl. pigtail)	
Control and display elements		Web interface for setup: user management, measurement settings, data output, measurement control, parameters, extras; 2 x color LEDs for Status / Ethernet and EtherCAT			

FSO = Full Scale Output

SMR = Start of measuring range, MMR = Mid of measuring range, EMR = End of measuring range

The specified data apply to white, diffuse reflecting surfaces (Micro-Epsilon reference ceramic for ILD sensors)

<sup>1)</sup> Value in brackets is valid for a measuring rate of 49.14 kHz

<sup>2)</sup> Measuring rate of 49.14 kHz with reduced measuring range (in brackets)

<sup>3)</sup> Measuring rate of 20 kHz

<sup>4)</sup> Connection via interface module (see accessories)



### Patented Blue Laser Technology

Measurement tasks involving Blue Laser sensors on red-hot glowing metals exceeding 700 °C and transparent objects such as plastics, adhesives and glass are patented by Micro-Epsilon. On these surfaces, the optoNCDT Blue Laser models achieve excellent signal stability and high precision measurement results.

**Accessories for all optoNCDT series****Power supply**

- PS 2020 (power supply 24 V / 2.5 A, input 100 - 240 VAC, output 24 VDC / 2.5 A, mounting onto symmetrical standard rail 35 mm x 7.5 mm, DIN 50022)

**Controller unit for evaluation and signal conversion**

- C-Box/2A (controller for conversion and evaluation of up to 2 sensor signals)

**Interface card**

- IF2008PCI / IF2008PCle (interface card for multiple signal processing; analog and digital interfaces)

**USB converter**

- IF2001/USB RS422/USB converter (converter for digital signals in USB)
- IF2004/USB 4-channel RS422/USB converter (converter for up to 4 digital signals in USB)

**Interface module for Industrial Ethernet connection**

- IF2030/PNET
- IF2030/ENETIP

**Accessories optoNCDT 1420/1402CL1****Supply and output cable (drag-chain suitable)**

- PCF1420-1/I (1 m, output 4 ... 20 mA)
- PCF1420-1/I(01) (1 m, output 4...20 mA)
- PCF1420-3/I (3 m, output 4 ... 20 mA)
- PCF1420-6/I (6 m, output 4 ... 20 mA)
- PCF1420-10/I (10 m, output 4 ... 20 mA)
- PCF1420-15/I (15 m, output 4 ... 20 mA)
- PCF1420-3/U (3 m, with integrated resistor, output 1 ... 5 VDC)\*
- PCF1420-6/U (6 m, with integrated resistor, output 1 ... 5 VDC)\*
- PCF1420-10/U (10 m, with integrated resistor, output 1 ... 5 VDC)\*
- PCF1420-15/U (15 m, with integrated resistor, output 1 ... 5 VDC)\*
- PCF1420-3/IF2008 (3 m, interface and supply cable)
- PCF1420-6/IF2008 (6 m, interface and supply cable)
- PCF1420-10/IF2008 (10 m, interface and supply cable)
- PCF1420-3/C-Box (3 m)

\* on request with output 2 ... 10 VDC

**Supply and output cable, suitable for use with robots**

(available in 90° version)

- PCR1402-3/I (3 m)
- PCR1402-6/I (6 m)
- PCR1402-8/I (8 m)

**Accessories for optoNCDT 1750BL / 1750DR / 1710 / 1710BL****Supply and output cable (drag-chain suitable)**

- PC1700-3 (3 m)
- PC1700-10 (10 m)
- PC1700-10/IF2008 (10 m, for use with interface card IF2008)
- PC1750-3/C-Box (3 m)
- PC1750-6/C-Box (6 m)
- PC1750-9/C-Box (9 m)

**Supply and output cable (suitable for use with robots)**

- PCR1700-5 (5 m)
- PCR1700-10 (10 m)

**Supply and output cables for temperatures up to 200 °C**

- PC1700-3/OE/HT (3 m)
- PC1700-6/OE/HT (6 m)
- PC1700-15/OE/HT (15 m)

**Protection housing**

- SGH model (sizes S and M)
- SGHF model (sizes S and M)
- SGHF-HT model

**Accessories for optoNCDT 2300/2300LL/2300BL/2300-2DR****Supply and output cable**

- PC2300-0,5Y (connection cable to PC or PLC; for operation a PC2300-3/SUB-D will be required)
- PC2300-3/SUB-D (3 m; for operation a PC2300-0,5Y will be required)
- PC2300-3/IF2008 (interface and supply cable)
- PC2300-3/OE (3 m)
- PC2300-6/OE (6 m)
- PC2300-9/OE (9 m)
- PC2300-15/OE (15 m)
- PC2300-3/C-Box/RJ45 (3 m)

\* other cable lengths on request

**Protection housing**

- SGH model (sizes S and M)
- SGHF model (sizes S and M)
- SGHF-HT model

**Supply and output cables for temperatures up to 200 °C**

- PC2300-3/OE/HT (3 m)
- PC2300-6/OE/HT (6 m)
- PC2300-9/OE/HT (9 m)
- PC2300-15/OE/HT (15 m)

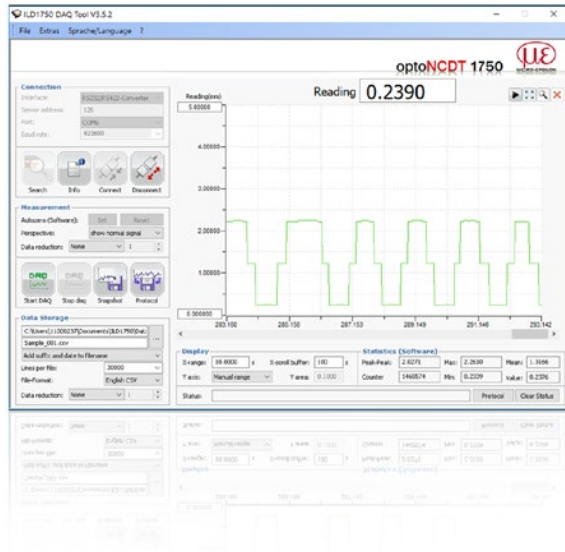

### optoNCDT Demo Tool

The scope of supply includes a software for easy sensor configuration. The settings can be implemented conveniently via a Windows user interface on the PC. The sensor parameters are transmitted to the sensor via the serial port and can also be saved if required. The software is available as single and multi-channel version. The sensor is connected to the PC via the sensor cable using a USB converter. [for any ILD sensor]

### Free download

Download free of charge from [www.micro-epsilon.com/download](http://www.micro-epsilon.com/download): software, driver and well-documented driver DLL for easy sensor integration in existing or customer software.

### Protection housing for demanding environments

To protect the optoNCDT laser sensors in harsh environments, protective housings are available in different designs.

#### SGH model

Completely enclosed housing with an integrated front window, where the sensor measures through the window. The water-resistant housing provides protection against solvents and detergents.

#### SGHF model

With window and compressed-air connection ideal for high ambient temperatures. The integrated air cooling of the housing offers optimum protection for the sensor.

#### SGHF-HT model

This water-cooled protection housing with window and compressed-air connection is designed for measurement tasks in ambient temperatures up to 200 °C.

Suitable for all long-range sensors

optoNCDT 1710

optoNCDT 1750-500 and optoNCDT 1750-750

optoNCDT 2310

optoNCDT 2300 - 200

Maximum ambient temperature 200 °C

Maximum temperature of cooling water  $T(\text{max}) = 10\text{ °C}$

Minimum water flow rate  $Q(\text{min}) = 3\text{ liters/min}$



SGHx ILD size S (140x140x71 mm)  
for optoNCDT 1750 / 2300 dimensions 97x75 mm



SGHx ILD size M (140x180x71 mm)  
for optoNCDT 1750 / 2300 dimensions 150x80 mm



### IF2008PCI/IF2008PCIe - PCI Interface card for synchronous data acquisition

The absolutely synchronous data acquisition is a decisive factor for the planarity or thickness measurement using several laser sensors. The IF2008PCI interface card is designed for installation in PCs and enables the synchronous capture of four digital sensor signals and two encoders. The data are stored in a FIFO memory in order to enable resource-saving processing in blocks in the PC. The IF2008E expansion board enables to detect in addition two digital sensor signals, two analog sensor signals and eight I/O signals.

#### Special features

- IF2008 basic printed circuit board: 4 digital signals and 2 encoders
- IF2008E - Expansion board: 2x digital signals, 2x analog signals and 8x I/O signals

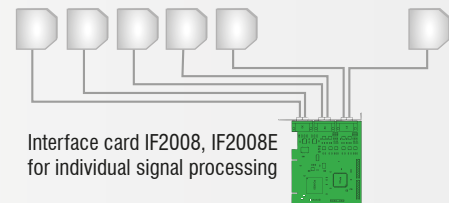
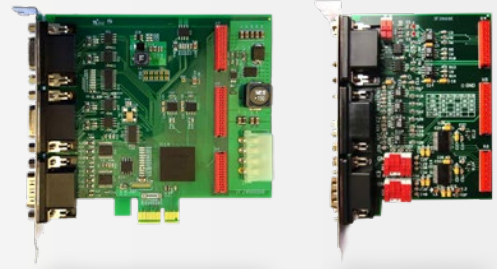

### IF2001/USB converter RS422 to USB

The RS422/USB converter transforms digital signals from a laser-optical sensor into a USB data packet. The sensor and the converter are connected via the RS422 interface of the converter. Data output is done via USB interface. The converter loops through further signals and functions such as laser on/off, switch signals and function output. The connected sensors and the converter can be programmed through software.

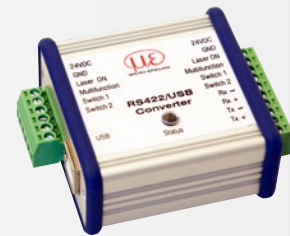

RS422 → USB

### IF2004/USB: 4-channel converter from RS422 to USB

The RS422/USB converter is used for transforming digital signals from up to four optical sensors into USB data signals. The converter has four trigger inputs and a trigger output for connecting additional converters. Data is output via an USB interface. The connected sensors and the converter can be programmed through software.

#### Special features

- 4x digital signals via RS422
- 4x trigger inputs, 1x trigger output
- Synchronous data acquisition
- Data output via USB



RS422  
RS422  
RS422  
RS422 → USB

### C-Box/2A Controller for D/A conversion and evaluation

C-Box/2A is used for fast D/A conversion of two digital input signals or for evaluating two digital sensor signals. The controller is compatible with the optoNCDT 1420, 1750 und 2300 models. Handling of the C-Box/2A and of the connected sensors are performed via web interface. Averaging functions, thickness, diameter, step and inclinations can be calculated. The D/A conversion is executed at 16 bit and max. 70 kHz.

#### Special features

- Trigger input
- Multi-function output
- Measurement value output via Ethernet, USB, analog output  
4 ... 20 mA / 0 ... 5 V / 0 ... 10 V /  $\pm 5$  V /  $\pm 10$  V  
(scalable via web interface)
- 2x switching outputs for sensors or C-Box/2A status
- Parallel data output via 3 output interfaces

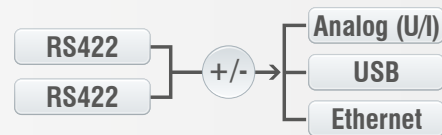

### IF2030

#### Interface module for Industrial Ethernet connection

The IF2030 interface modules are designed for easy connection of Micro-Epsilon sensors to Ethernet-based fieldbuses, e.g., plant control systems. The PROFINET and Ethernet/IP modules are compatible with sensors that output data via an RS422 or RS485 interface. These modules operate on the sensor side with up to 4 MBd and have two network connections for different network topologies. Installation in switching cabinets is via a DIN rail.



EtherNet/IP

PROFINET

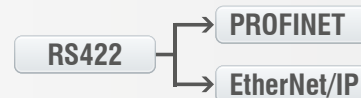

## Sensors and Systems from Micro-Epsilon



Sensors and systems for displacement, distance and position



Sensors and measurement devices for non-contact temperature measurement



Measuring and inspection systems for metal strips, plastics and rubber



Optical micrometers and fiber optics, measuring and test amplifiers



Color recognition sensors, LED analyzers and inline color spectrometers

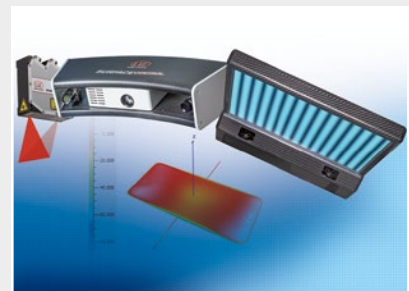

3D measurement technology for dimensional testing and surface inspection



**SCIGATE AUTOMATION (S) PTE LTD**

No 1 Bukit Batok Street 22 #01-01 Singapore 659592

Tel: (65) 6561 0488

Fax: (65) 6561 0588

Email: [sales@scigate.com.sg](mailto:sales@scigate.com.sg)

Web: <https://scigate.com.sg/>

Business Hours: Monday - Friday 8:30AM - 6:15PM



**MICRO-EPSILON**

MICRO-EPSILON USA

8120 Brownleigh Dr. · Raleigh, NC 27617 / USA

Phone +1/919/787-9707 · Fax +1/919/787-9706

[me-usa@micro-epsilon.com](mailto:me-usa@micro-epsilon.com) · [www.micro-epsilon.com](http://www.micro-epsilon.com)