



SCIGATE AUTOMATION (S) PTE LTD

No.1 Bukit Batok Street 22 #01-01 Singapore 659592

Tel: (65) 6561 0488

Fax: (65) 6562 0588

Email: sales@scigate.com.sg

Web: www.scigate.com.sg

Business Hours: Monday - Friday 8.30am - 6.15pm

More Precision

scanCONTROL // 2D/3D Laser profile sensors

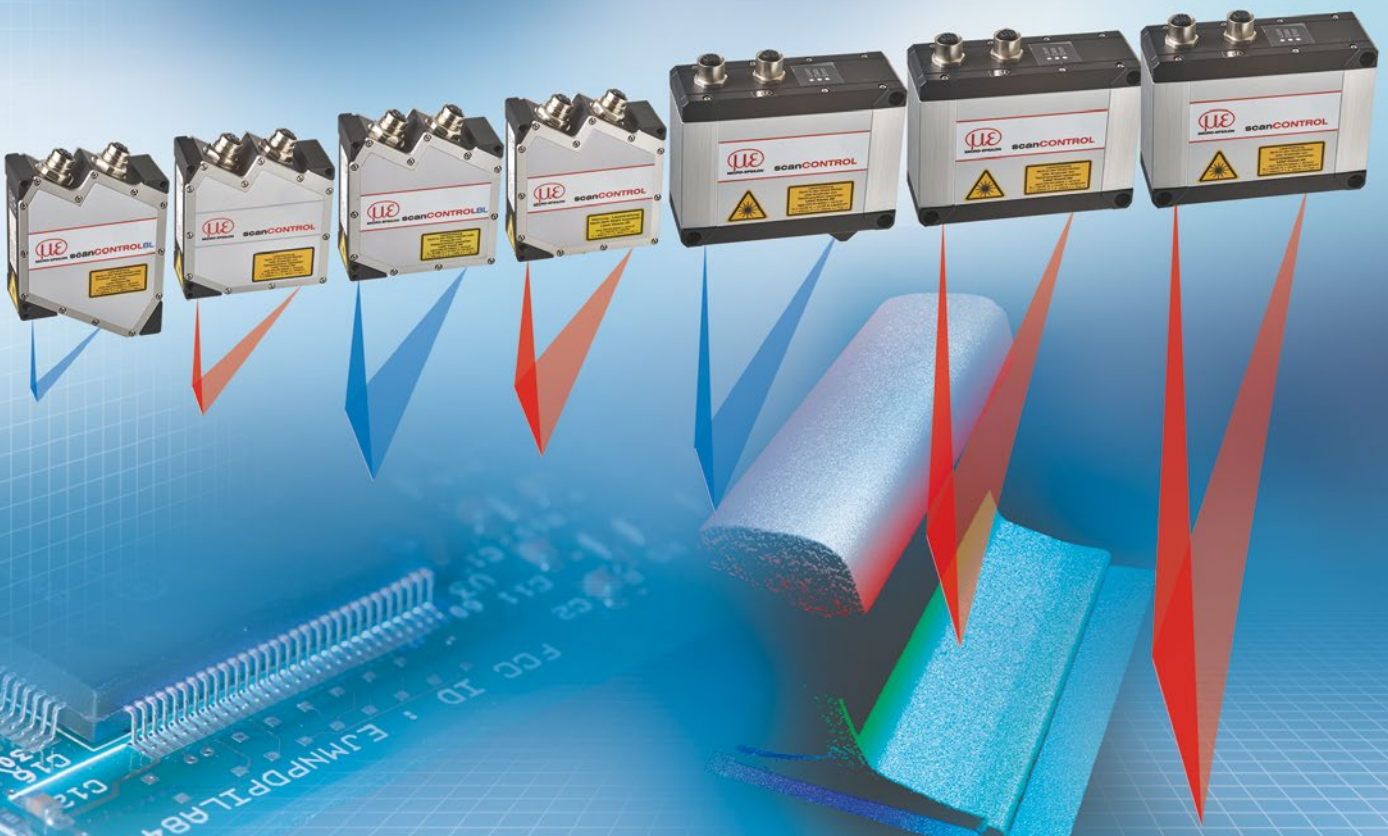



NEW

scanCONTROL 3000

scanCONTROL LLT3000 laser profile scanners impress in 2D/3D measurement tasks with high precision and dynamics. With their high resolution sensor matrix and high profile frequency, these scanners are designed for precise profile measurements in dynamic processes.

- High performance scanner: 2048 points / profile and 10 kHz profile frequency
- HDR mode for accurate measurement results on inhomogeneous surfaces
- Measuring ranges from 25 to 200 mm

NEW

scanCONTROL 3002

- Powerful scanner: 1024 points / profile and 5 kHz profile frequency
- Measuring ranges 25 to 200 mm

NEW

scanCONTROL 2500

- Compact scanner with high signal stability
- Full SMART functionality
- NEW: now with 2 kHz profile frequency and Blue Laser Technology

Content / Model	Description	Page
scanCONTROL	Advantages and special features	4 - 5
scanCONTROL	Measuring principle Software features	6 - 7
scanCONTROL	All products at a glance Measuring range	8 - 9
scanCONTROL	Application examples	10 - 11
scanCONTROL 25x0	Laser scanner for industrial series applications <ul style="list-style-type: none"> ▪ Technical data ▪ Dimensions and measuring ranges 	12 - 13 16 - 19
scanCONTROL 29x0	Compact laser scanner with high precision <ul style="list-style-type: none"> ▪ Technical data ▪ Dimensions and measuring ranges 	14 - 15 16 - 19
scanCONTROL 30x2	Powerful 2D/3D laser scanners <ul style="list-style-type: none"> ▪ Technical data ▪ Dimensions and measuring ranges 	20 - 21 24 - 27
scanCONTROL 30x0	Powerful 2D/3D laser scanners with highest precision <ul style="list-style-type: none"> ▪ Technical data ▪ Dimensions and measuring ranges 	22 - 23 24 - 27
Software	<ul style="list-style-type: none"> ▪ scanCONTROL Configuration Tools / Configuration ▪ scanCONTROL 3D-View ▪ scanCONTROL 3DInspect 	28 - 33
Integration of scanCONTROL	Interfaces for parameter settings and data transfer functions Ethernet and GigE Vision, C++ , LabVIEW, Linux	34 - 35
System for multi-scanner applications	Application software for combination of measured values/ scanCONTROL Smart PLC Unit	36 - 37
Accessories	<ul style="list-style-type: none"> ▪ 2D/3D Gateway ▪ 2D/3D Output Unit ▪ Protection and cooling housings ▪ Connection cables 	38 39 40 - 41 42
3D sensors for shape and surface measurements	<ul style="list-style-type: none"> ▪ surfaceCONTROL 3D 3500 ▪ reflectCONTROL 	43



Compact size and integrated evaluation without external controller or IPC

High profile resolution for the detection of finest details

High profile rate for dynamic measurement tasks

Made / Developed in Germany

Numerous references worldwide

Proven high operational safety in the 24/7 operation over many years

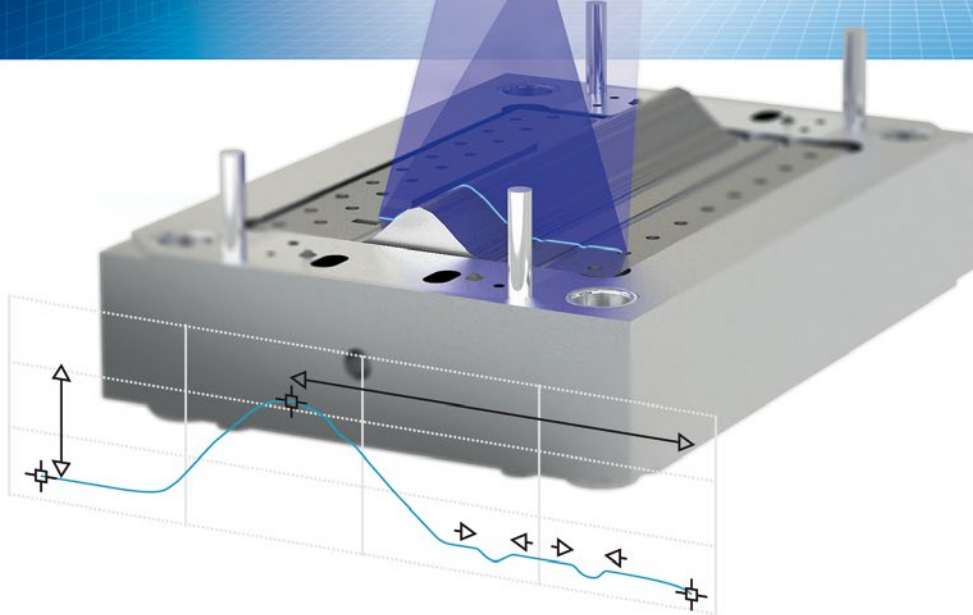

Compact. Powerful. Integrable.

Laser profile scanners from Micro-Epsilon are among the highest performing profile sensors with respect to accuracy and measuring rate. Equipped with powerful processors and highly sensitive optical components, these scanners ensure precise profile measurements on almost any type of surface.

While they can be integrated in various environments, the scanners also impress with compact design which includes an integrated controller.

Universal Application

- Comprehensive scanner portfolio for transmission of profiles or measured values in industrial measurement tasks
- 2D inline measurement of different parameters (gap, step, radius, circle)
- 3D data and images for image processing
- Also suitable for robots & multi-sensor applications

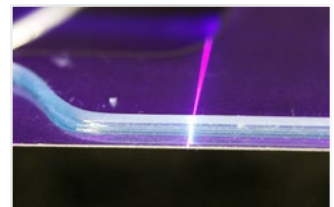
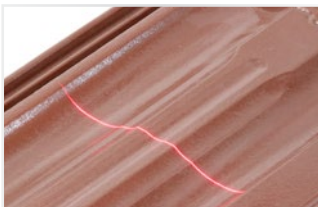

Integrated Controller for Direct Processing

scanCONTROL laser scanners have an integrated controller and therefore do not require any external control unit. This considerably simplifies wiring and their integration into restricted spaces or on a robot. The available interfaces allow the scanners to be integrated in industrial environments. For multi-scanner applications, interface modules are available.

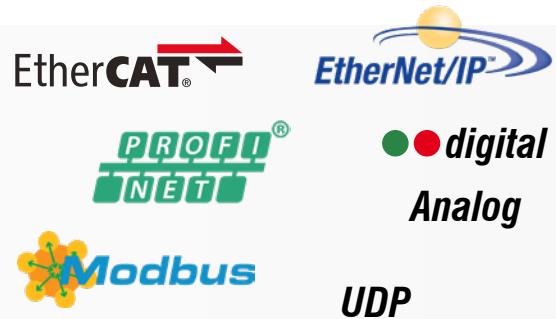

Real Time Surface Compensation

Dynamic adaption to rapidly changing surfaces

Laser profile scanners use diffusely reflected laser light of which the intensity is highly dependent on the color and how shiny and reflective the respective component is. In order to be able to measure reliably under rapidly changing conditions, scanCONTROL sensors offer the Real-Time-Surface-Compensation feature. Due to this smart feature, the exposure time and the threshold of reflection detection are adapted in real time in order to generate stable measurement results. Moreover, the scanCONTROL 3000 series comes with an HDR function which ensures accurate detection of inhomogeneous surfaces.

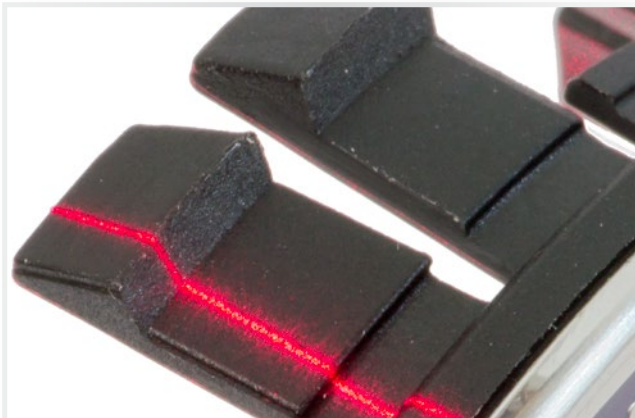
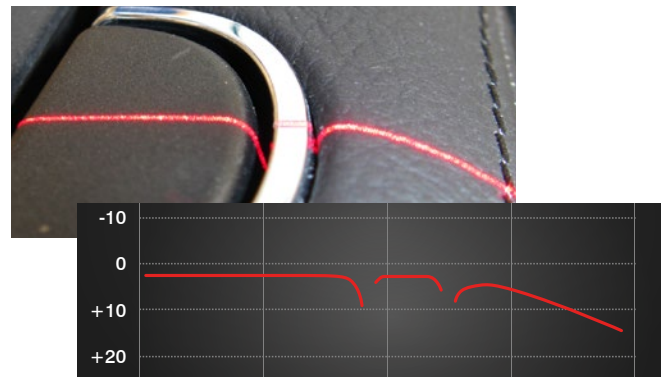

Red and Blue Laser

Laser scanners from Micro-Epsilon are available with red and blue laser. For common measurement tasks, scanCONTROL laser scanners with red laser line are used. With objects into which the laser light penetrates, such as transparent or organic surfaces, blue laser scanners are recommended. Blue Laser scanners are also ideal for red-hot glowing metals.

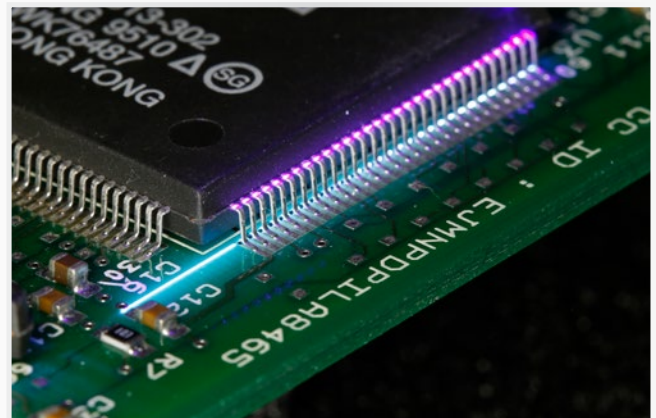

Patent Protection

for red-hot glowing and transparent objects

The internationally patented measurement methods for Blue Laser Technology allow precise measurements to be made on transparent or red-hot glowing objects above 700 °C.

Transparent objects include plastics, glass, adhesives, silicones, paints, coatings, Plexiglas and seals. Any questions about Blue Laser scanners? We will be pleased to advise you.

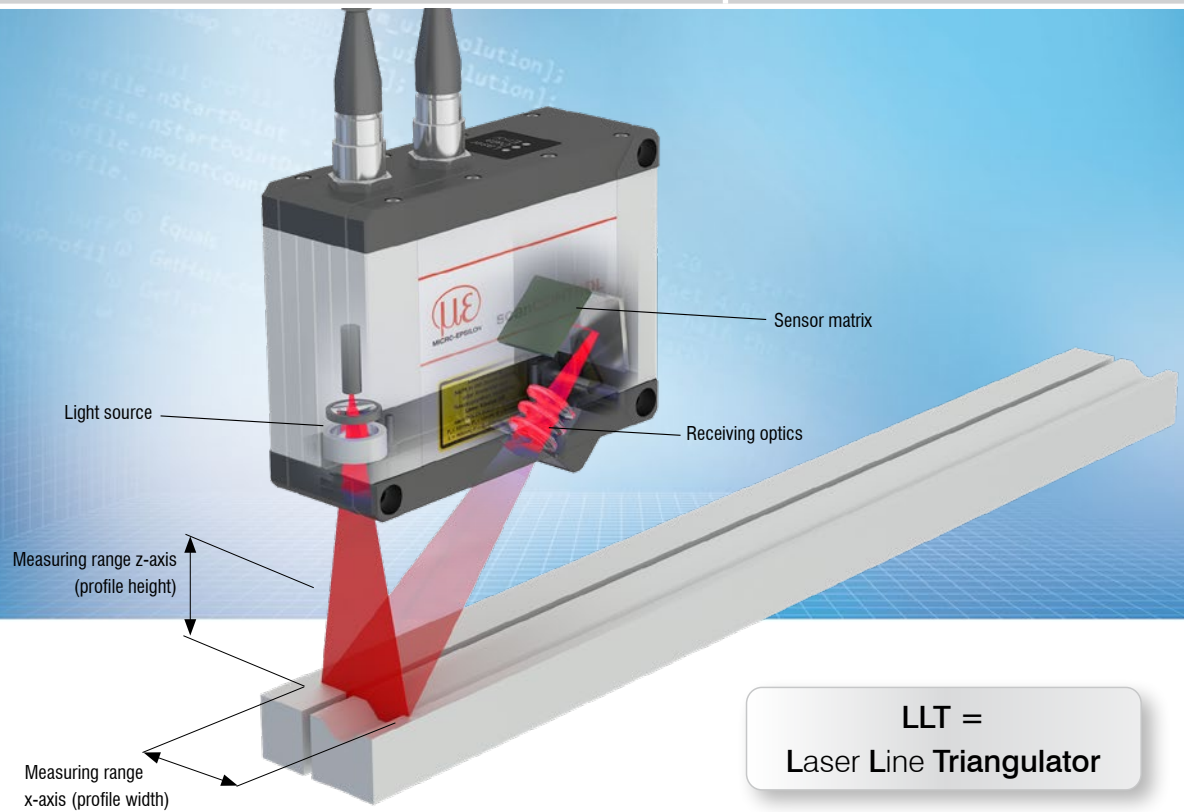

The principle of laser line triangulation

Laser scanners – often referred to as profile sensors – use the laser triangulation principle for two-dimensional profile detection on different target surfaces. By using special lenses, a laser beam is enlarged to form a static laser line and is projected onto the target surface. The receiving optics projects the diffusely reflected light of this laser line onto a highly sensitive sensor matrix. In addition to distance information (z-axis), the controller also uses this camera image to calculate the position along the laser line (x-axis). These measured values are subsequently output in a two-dimensional coordinate system that is fixed with respect to the sensor. In the case of moving objects or a traversing sensor, it is therefore possible to obtain 3D measurement values.

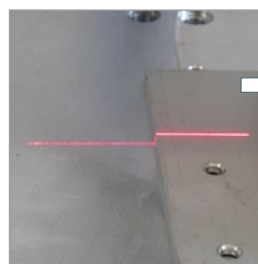

Laser line
Projecting a laser line
onto the target surface

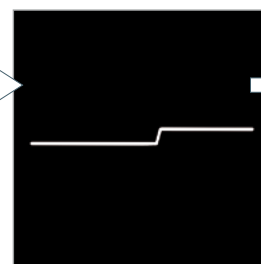

Sensor matrix (pixels)
Diffuse reflected light of the laser line
is registered by a high quality sensor
array

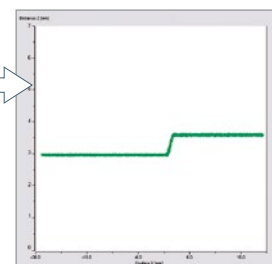

Calibrated x/z measuring points
Calculation of the distance coordinate z
and the actual position x along the laser
line for each measuring point

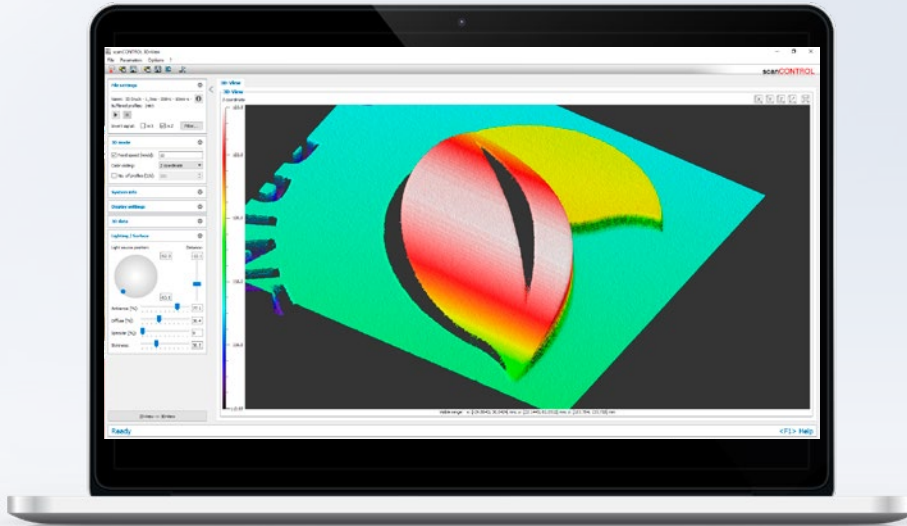

Powerful Software

The scanCONTROL Configuration Tools software offers numerous measuring programs with a total of 94 evaluation variants. This is how all important profile measurement tasks can be set up and combined.

- User-friendly parameter software for all scanCONTROL SMART models
- Analysis and evaluation directly in the sensor

Powerful SDKs

- Libraries for C, C++, C# and VB
- LabVIEW driver
- Linux implementation

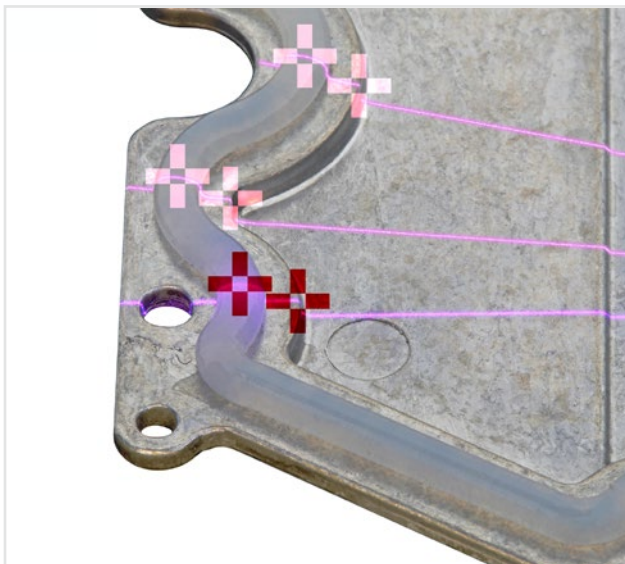

Intelligent Tracking

scanCONTROL SMART sensors can be used to track complex structures and to guide robots. Therefore, anchor points are set in the Configuration Tools software which are used to track and measure the profiles.

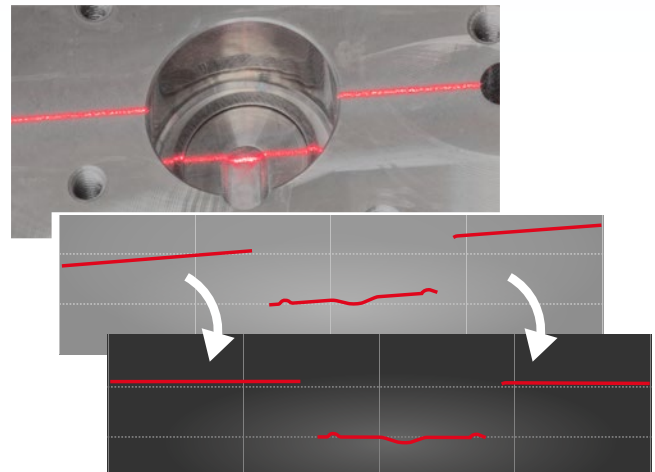

Profile Correction

With obliquely detected profiles, the Configuration Tools software corrects the inclination and therefore simplifies the sensor alignment.

COMPACT

Evaluation by customer

The COMPACT models provide **calibrated profile data** that can be further processed on a PC with software evaluation provided by the customer.

**LLT25x0**

640 points/profile
Profile frequency up to 2,000 Hz
Red laser / blue laser

scanCONTROL
2500

**LLT29x0**

1280 points/profile
Profile frequency
Standard up to 300 Hz
High speed up to 2,000 Hz
Red laser / blue laser

scanCONTROL
2900

**LLT30x2**

1024 points/profile
Profile frequency up to 5,000 Hz
Red laser / blue laser

scanCONTROL
3002

**LLT30x0**

2048 points/profile
Profile frequency up to 10,000 Hz
Red laser / blue laser

scanCONTROL
3000

Integration: SDK for C/ C++, LabVIEW-VI and examples for C#, Linux and VB are available.

SMART

Integrated evaluation

The SMART models provide selected **measurement values**. The parameter setup for the sensors and the measurement programs are stored in the internal controller.

scanCONTROL
2510

scanCONTROL
2910

scanCONTROL
3012

scanCONTROL
3010

Evaluation:
scanCONTROL Configuration Tools

scanCONTROL 2500 and 2900

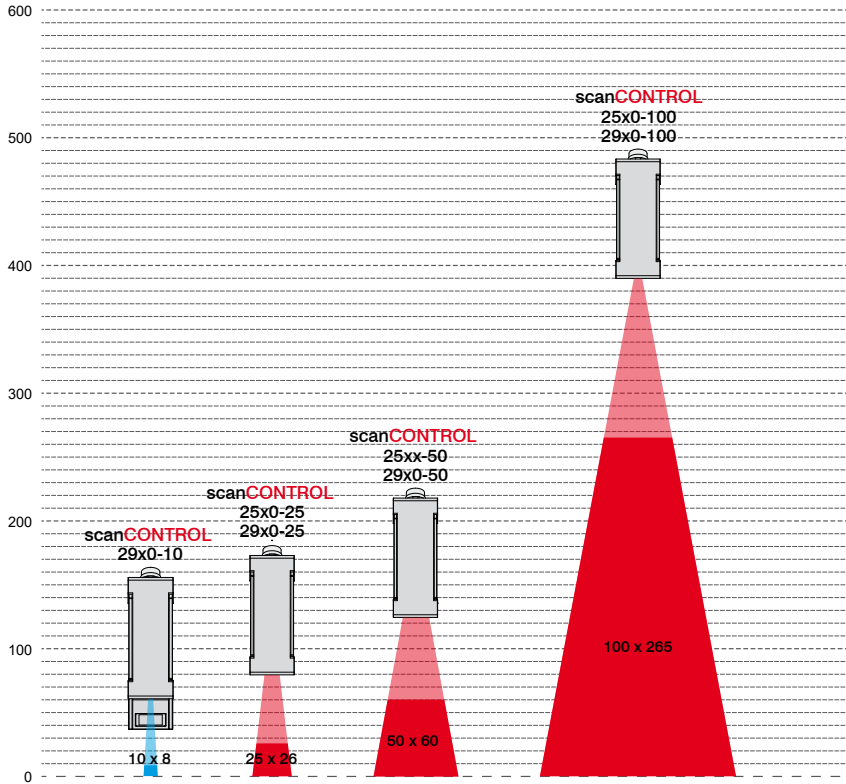

scanCONTROL laser profile scanners feature a wide range of different measuring ranges from 10 x 8 mm up to 200 x 300 mm. In all measuring ranges, these laser scanners impress both with fast measurements and high precision.

The variety of measuring ranges allows, on the one hand, both the acquisition of smallest details and structures, and, on the other hand, the measurement of large objects with a large offset distance. For this reason, scanCONTROL sensors are used for numerous measurement tasks in various industries.

scanCONTROL 3002 and 3000

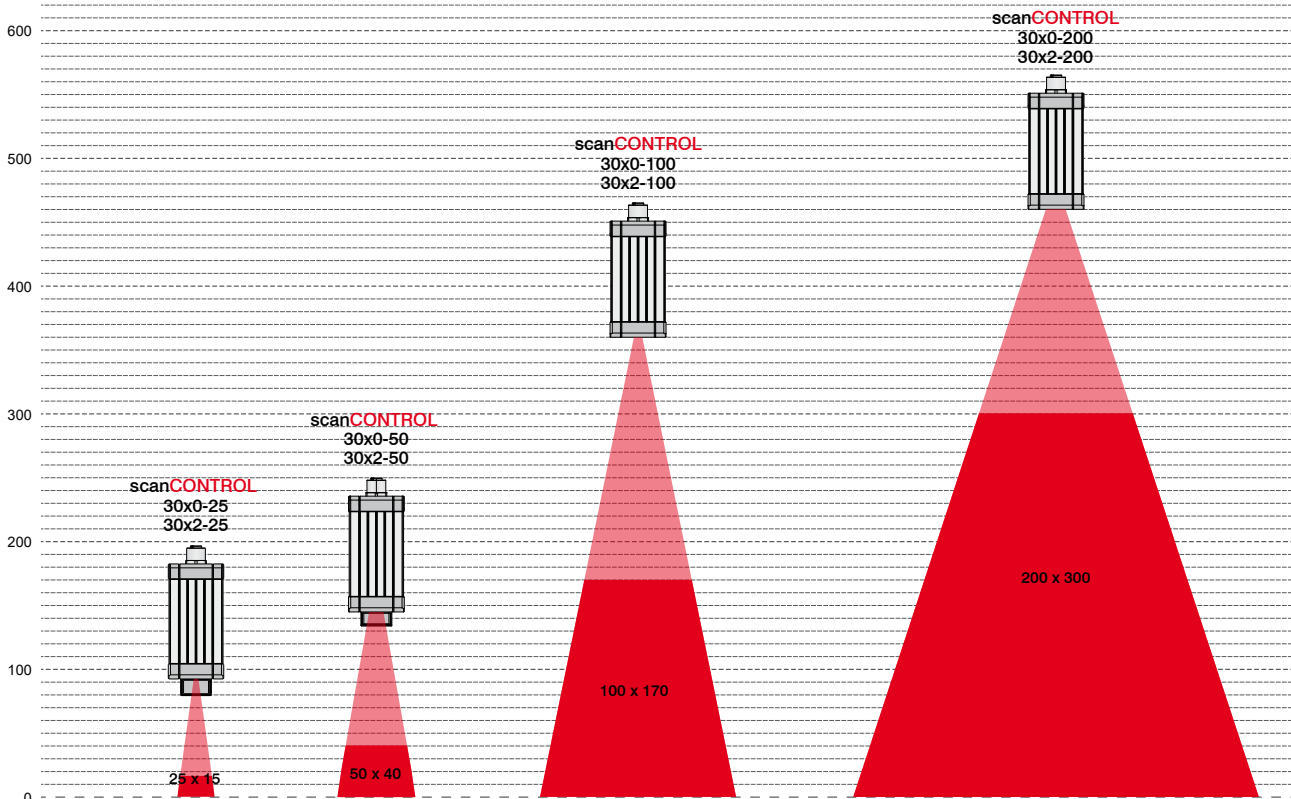

scanCONTROL

Red laser scanners are ideally suited to numerous measurement tasks. A higher light intensity and better performance on weakly reflective or matt surfaces, especially with fast moving objects, make the red laser scanners ideal for common measurement tasks.

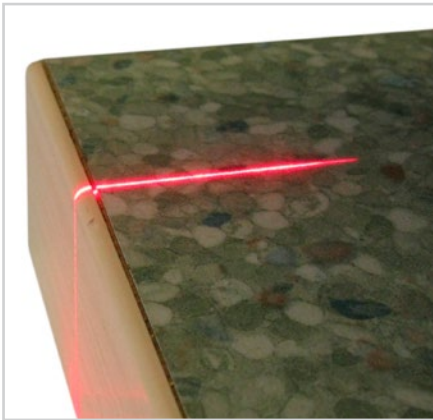

Defect recognition on worktops

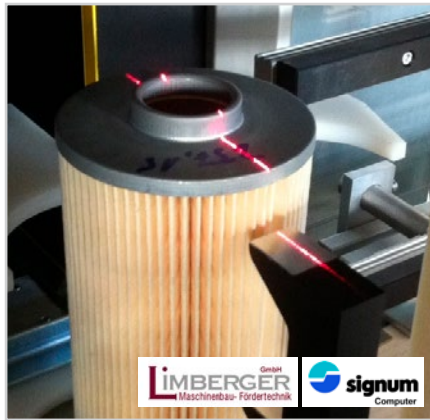

Filter height measurement for the automotive industry

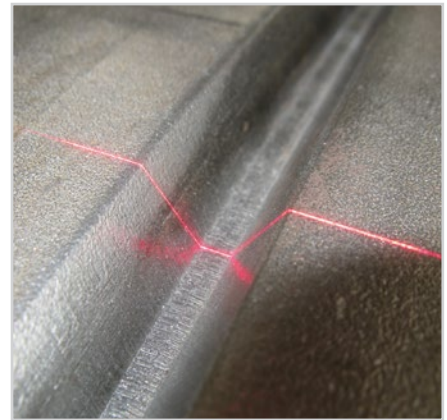

V-gap measurement on pipes



Gap measurement on car bodies



Profile measurement of the brake disc



Text recognition on the cast part



Tire control

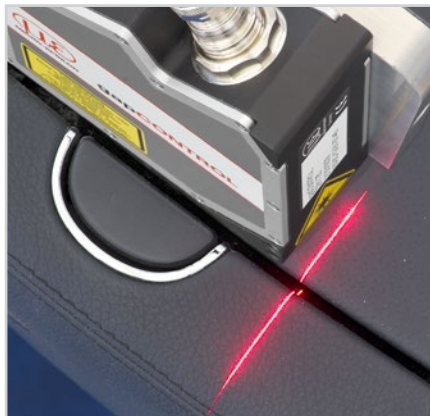

Distance measurement at the center console

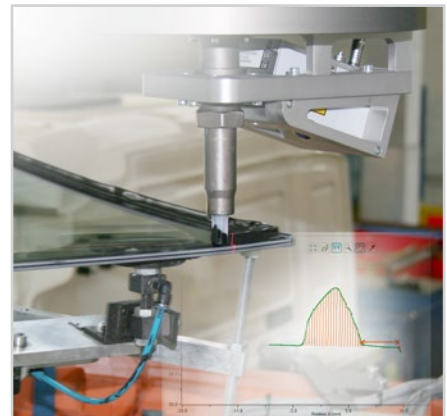

Inspection of the adhesive beading

scanCONTROL BL

For profile measurements on red-hot glowing metals as well as transparent and organic surfaces, laser scanners with blue laser line are recommended. While allowing higher stability, the blue laser light does not penetrate the measuring object due to the shorter wavelength of the blue-violet laser. Compared to red lasers, blue laser sensors ensure higher reliability with measurements on red-hot glowing, organic and (semi-)transparent objects.

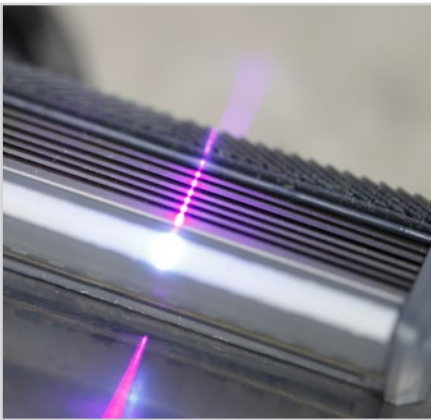

Razor blade angle

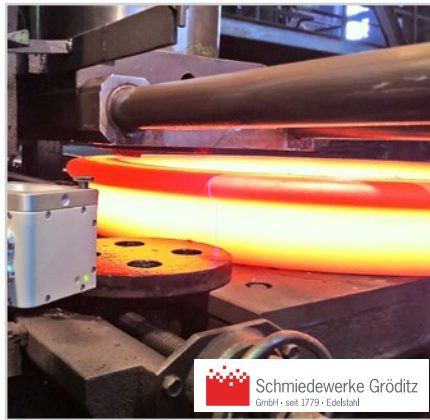

Production of steel-forged rings

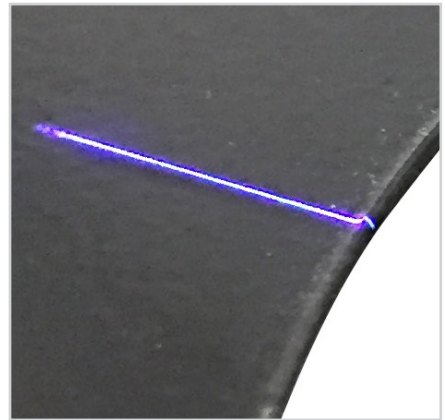

Burr measurement on punching sheets

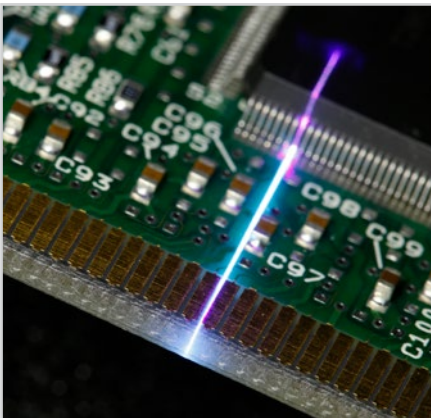

Position of electronic components

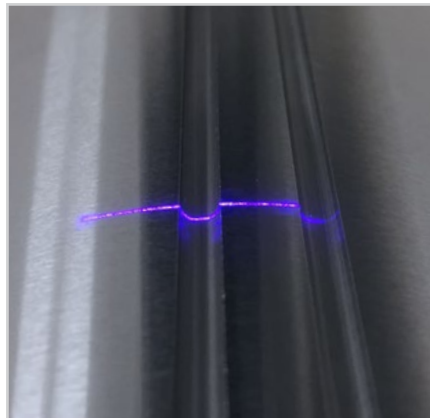

Notch position in silicon ingots

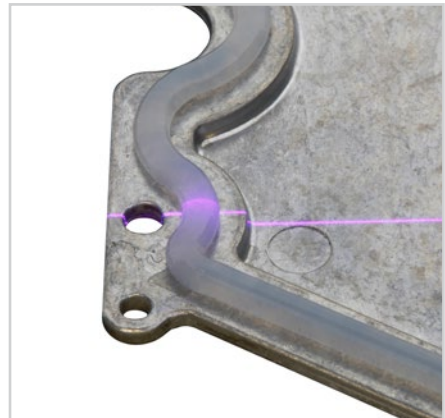

Inspection of silicone beads

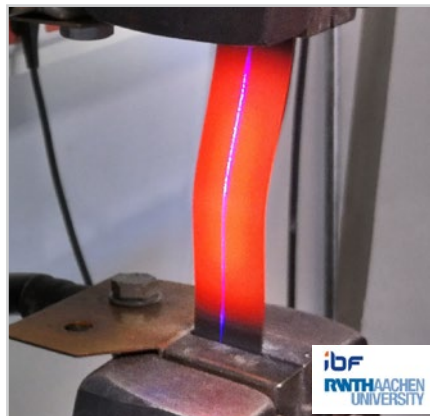
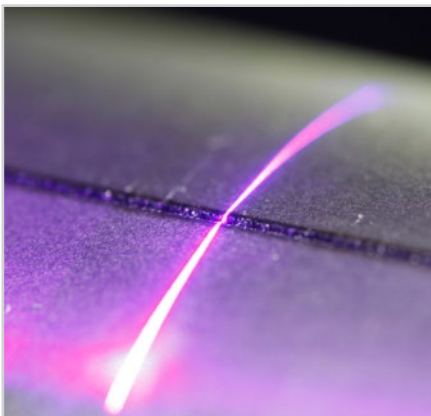

Blue Laser patent protection with red-hot glowing and transparent surfaces

Measurements involving blue laser scanners on red-hot glowing objects exceeding 700 °C and (semi-)transparent objects are protected by patent law. Transparent objects include plastics, glass, adhesives, silicones, paints, coatings, Plexiglas and seals. Any questions about Blue Laser scanners? We will be pleased to advise you.



Ideal for industrial series applications in production line & automation

Resolution (x-axis) 640 points

High signal stability

Also available with patented Blue Laser Technology

Ideal for series applications

scanCONTROL 25x0 laser scanners are designed for industrial measurement tasks. Thanks to their high signal stability, versatility and excellent price-performance ratio, the scanners are particularly suitable for measurement tasks involving large quantities. They measure and evaluate, e.g., angles, steps, gaps, distances and extreme values. Due to their compact design and low weight, these scanners are also suitable for applications with high accelerations, such as on robots.

Available as COMPACT and SMART versions

The scanCONTROL 25x0 series is available as COMPACT and SMART versions. The COMPACT scanners provide calibrated profile data that can be further processed on a PC with software evaluation provided by the customer. SMART scanners operate autonomously and provide selected measurement values. The sensor parameters and the desired measuring programs are set in the scanCONTROL Configuration Tools software and directly stored in the internal controller.

Ideal for production and machine monitoring

The scanCONTROL 25x0 laser scanners are available with three measuring ranges with red or blue laser. Optional accessories, cable types and interface modules allow a wide range of applications in the production line and in machine building.

Article designation

LLT	25	00	-25	/PT	
Options - see below					
Measuring range					
25 mm					
50 mm					
100 mm					
Class					
00=COMPACT					
10=SMART					
Series					
LLT25x0					

Laser options*

	/SI	Hardware switch-off of the laser line
	/3B	Increased laser power (class 3B, ≤ 20 mW), e.g., for dark surfaces
	/BL	Blue laser line (405 nm) for (semi-) transparent, red-hot glowing and organic materials

Cable output options*

	/PT	Cable directly out of the sensor ("Pigtail") Length 0.25 m
--	-----	---

*Options can be combined

Model		LLT 25xx-25	LLT 25xx-50	LLT 25xx-100	
Available laser type		Red Laser Blue Laser	Red Laser Blue Laser	Red Laser Blue Laser	
z-axis	Measuring range	Start of measuring range	53.5 mm	70 mm	190 mm
		Mid of measuring range	66 mm	95 mm	240 mm
		End of measuring range	78.5 mm	120 mm	290 mm
	Extended measuring range	Height of measuring range	25 mm	50 mm	100 mm
		Start of measuring range	53 mm	65 mm	125 mm
		End of measuring range	79 mm	125 mm	390 mm
Linearity ^{1) 2)}		2 μm	4 μm	12 μm	
		±0.008 %	±0.008 %	±0.012 %	
x-axis	Measuring range	Start of measuring range	23.4 mm	42 mm	83.1 mm
		Mid of measuring range	25 mm	50 mm	100 mm
		End of measuring range	29.1 mm	58 mm	120.8 mm
	Extended measuring range	Start of measuring range	23.2 mm	40 mm	58.5 mm
		End of measuring range	29.3 mm	60 mm	143.5 mm
	Resolution		640 points/profile		
Profile frequency		up to 2,000 Hz			
Interfaces	Ethernet GigE Vison	Output of measurement values Sensor control Profile data transmission			
	Digital inputs	Mode switching Encoder (counter) Trigger			
	RS422 (half-duplex) ³⁾	Output of measurement values Sensor control Trigger Synchronization			
Output of measurement values		Ethernet (UDP / Modbus TCP); RS422 (ASCII / Modbus RTU) analog ⁴⁾ ; switch signal ⁴⁾ PROFINET ⁵⁾ ; EtherCAT ⁵⁾ ; EtherNet/IP ⁵⁾			
Control and display elements		3x color LEDs for laser, data and error ≤ 8 mW			
Light source	Red Laser	Standard: laser class 2M, semiconductor laser 658 nm ≤ 20 mW			
	Blue Laser	Option: laser class 3B, semiconductor laser 658 nm ≤ 8 mW			
	Laser switch-off	Standard: laser class 2M, semiconductor laser 405 nm via software, hardware switch-off with /SI option			
Aperture angle of laser line	20°	25°	25°		
Permissible ambient light (fluorescent light) ¹⁾		10,000 lx			
Protection class (DIN EN 60529)		IP65 (when connected)			
Vibration (DIN EN 60068-2-27)		2 g / 20 ... 500 Hz			
Shock (DIN EN 60068-2-6)		15 g / 6 ms			
Temperature range	Storage	-20 ... +70 °C			
	Operation	0 ... +45 °C			
Weight		380 g (without cable)			
Supply voltage		11 ... 30 VDC, nominal value 24 V, 500 mA, IEEE 802.3af class 2, Power over Ethernet (PoE)			

¹⁾ According to measuring range; Measuring object: Micro-Epsilon standard object

²⁾ According to a one-time averaging over the width of the measuring field (640 points)

³⁾ RS422 interface, programmable either as serial interface or as input for triggering/synchronization

⁴⁾ Only with 2D/3D Output Unit

⁵⁾ Only with 2D/3D Gateway



- Ideal for precise 2D/3D measurements
- Resolution (x-axis) 1,280 points
- High accuracy for the detection of finest details
- Profile frequency up to 2,000 Hz
- Also available with patented Blue Laser Technology

Compact design for precise measurements

scanCONTROL 29x0 laser scanners are designed for industrial measurement tasks where compact design and high accuracy are required. Thanks to their high resolution, versatility and excellent price-performance ratio, the scanners are particularly suitable for static and dynamic applications, e.g., on robots. They measure and evaluate, e.g., angles, steps, gaps, distances and extreme values.

Available as COMPACT and SMART versions

The scanCONTROL 29x0 series is available as COMPACT and SMART versions. The COMPACT scanners provide calibrated profile data that can be further processed on a PC with software evaluation provided by the customer. SMART scanners operate autonomously and provide selected measurement values. The sensor parameters and the desired measuring programs are set in the scanCONTROL Configuration Tools software and directly stored in the internal controller.

Small measuring range with high resolution

With a laser line of just 10 mm, the scanCONTROL 29x0-10/BL models recognize the finest of details and structures. The high profile resolution combined with the blue laser line allow for maximum precision in versatile applications, e.g., monitoring in electronics production.

Article designation

LLT	29	00	-25	/SI
Options - see below				
Measuring range				
10 mm (only Blue Laser)				
25 mm				
50 mm				
100 mm				
Class				
00=COMPACT				
10=SMART				
50=HIGHSPEED				
60=HIGHSPEED SMART				
Series				
LLT29x0				

Laser options*

	/SI	Hardware switch-off of the laser line
	/3B	Increased laser power (class 3B, ≤ 20 mW), e.g., for dark surfaces
	/BL	Blue laser line (405 nm) for (semi-) transparent, red-hot glowing and organic materials

Cable output options*

	/PT	Cable directly out of the sensor ("Pigtail") Length 0.25 m
	/VT	Cable directly out of the sensor ("Variable Tail") Length 0.1 ... 1.0 m (freely selectable)

*Options can be combined

Model		LLT29x0-10/BL	LLT 29xx-25		LLT 29xx-50		LLT 29xx-100	
Available laser type		Blue Laser	Red Laser	Blue Laser	Red Laser	Blue Laser	Red Laser	Blue Laser
Z-axis	Measuring range	Start of measuring range	52.5 mm	53.5 mm	70 mm	190 mm		
		Mid of measuring range	56.5 mm	66 mm	95 mm	240 mm		
		End of measuring range	60.5 mm	78.5 mm	120 mm	290 mm		
		Height of measuring range	8 mm	25 mm	50 mm	100 mm		
	Extended measuring range	Start of measuring range	-	53 mm	65 mm	125 mm		
		End of measuring range	-	79 mm	125 mm	390 mm		
Linearity ¹⁾²⁾		1 μm	2 μm	4 μm	12 μm			
		±0.0125 %	±0.008 %	±0.008 %	±0.012 %			
X-axis	Measuring range	Start of measuring range	9.4 mm	23.4 mm	42 mm	83.1 mm		
		Mid of measuring range	10 mm	25 mm	50 mm	100 mm		
		End of measuring range	10.7 mm	29.1 mm	58 mm	120.8 mm		
	Extended measuring range	Start of measuring range	-	23.2 mm	40 mm	58.5 mm		
		End of measuring range	-	29.3 mm	60 mm	143.5 mm		
	Resolution		1,280 points/profile					
Profile frequency	Standard	up to 300 Hz						
	Highspeed	up to 2,000 Hz						
Interfaces	Ethernet GigE Vison	Output of measurement values Sensor control Profile data transmission						
	Digital inputs	Mode switching Encoder (counter) Trigger						
	RS422 (half-duplex) ³⁾	Output of measurement values Sensor control Trigger Synchronization						
Output of measurement values	Ethernet (UDP / Modbus TCP); RS422 (ASCII / Modbus RTU) analog ⁴⁾ ; switch signal ⁴⁾ PROFINET ⁵⁾ ; EtherCAT ⁵⁾ ; EtherNet/IP ⁵⁾							
Control and display elements	3x color LEDs for laser, data and error							
Light source		-	≤ 8 mW					
	Red Laser	-	Standard: laser class 2M, semiconductor laser 658 nm					
		-	≤ 20 mW					
		-	Option: laser class 3B, semiconductor laser 658 nm					
	Blue Laser		≤ 8 mW					
	Laser switch-off		Standard: laser class 2M, semiconductor laser 405 nm					
Aperture angle of laser line		10°	20°	25°	25°			
Permissible ambient light (fluorescent light) ¹⁾	10,000 lx							
Protection class (DIN EN 60529)	IP65 (when connected)							
Vibration (DIN EN 60068-2-27)	2 g / 20 ... 500 Hz							
Shock (DIN EN 60068-2-6)	15 g / 6 ms							
Temperature range	Storage	-20 ... +70 °C						
	Operation	0 ... +45 °C						
Weight		440 g (without cable)			380 g (without cable)			
Supply voltage	11 ... 30 VDC, nominal value 24 V, 500 mA, IEEE 802.3af class 2, Power over Ethernet (PoE)							

¹⁾ According to measuring range; Measuring object: Micro-Epsilon standard object
²⁾ According to a one-time averaging over the width of the measuring field (640 points)
³⁾ RS422 interface, programmable either as serial interface or as input for triggering/synchronization
⁴⁾ Only with 2D/3D Output Unit
⁵⁾ Only with 2D/3D Gateway

LLT29x0-10/BL

Blue Laser

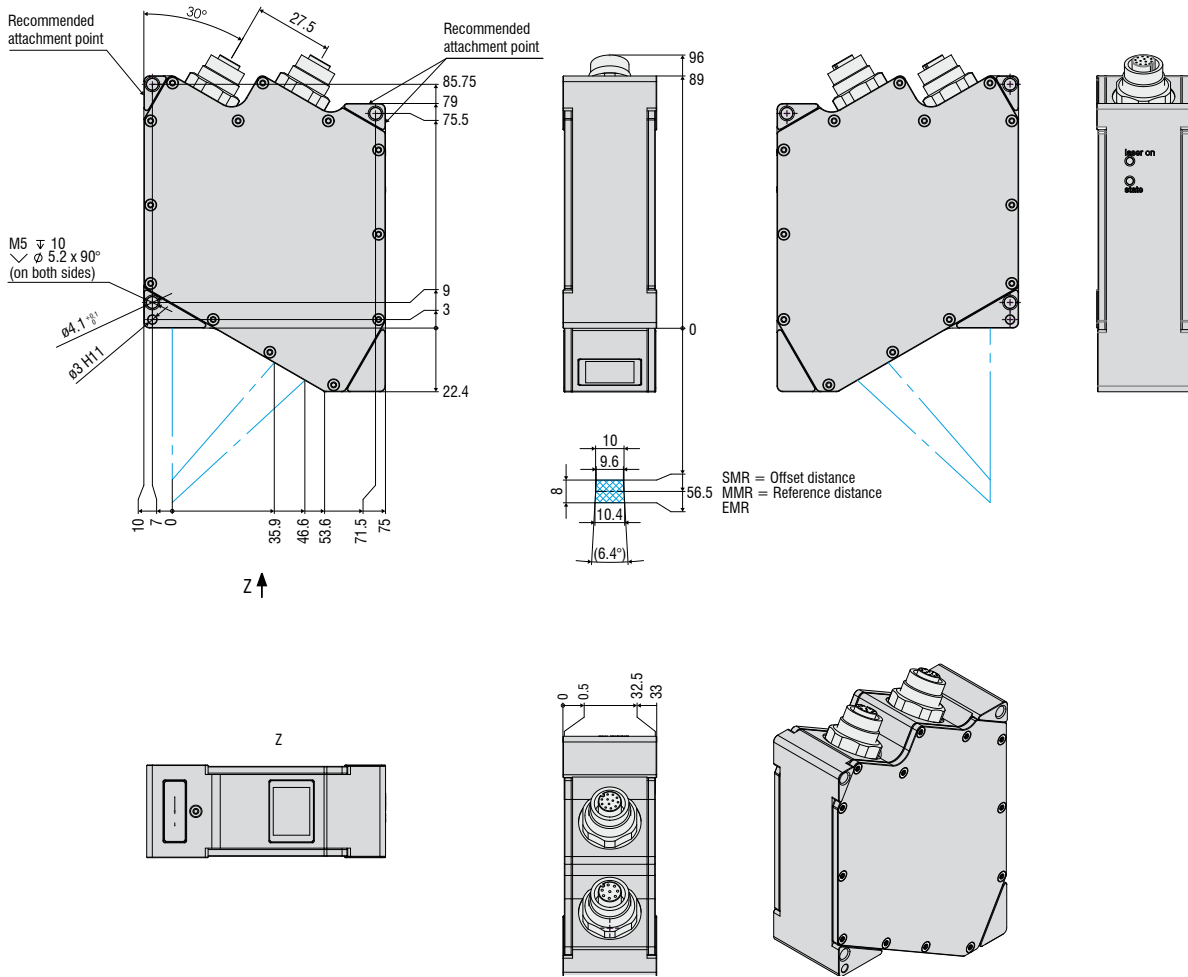

LLT25x0-25 / LLT29x0-25

Red Laser Blue Laser

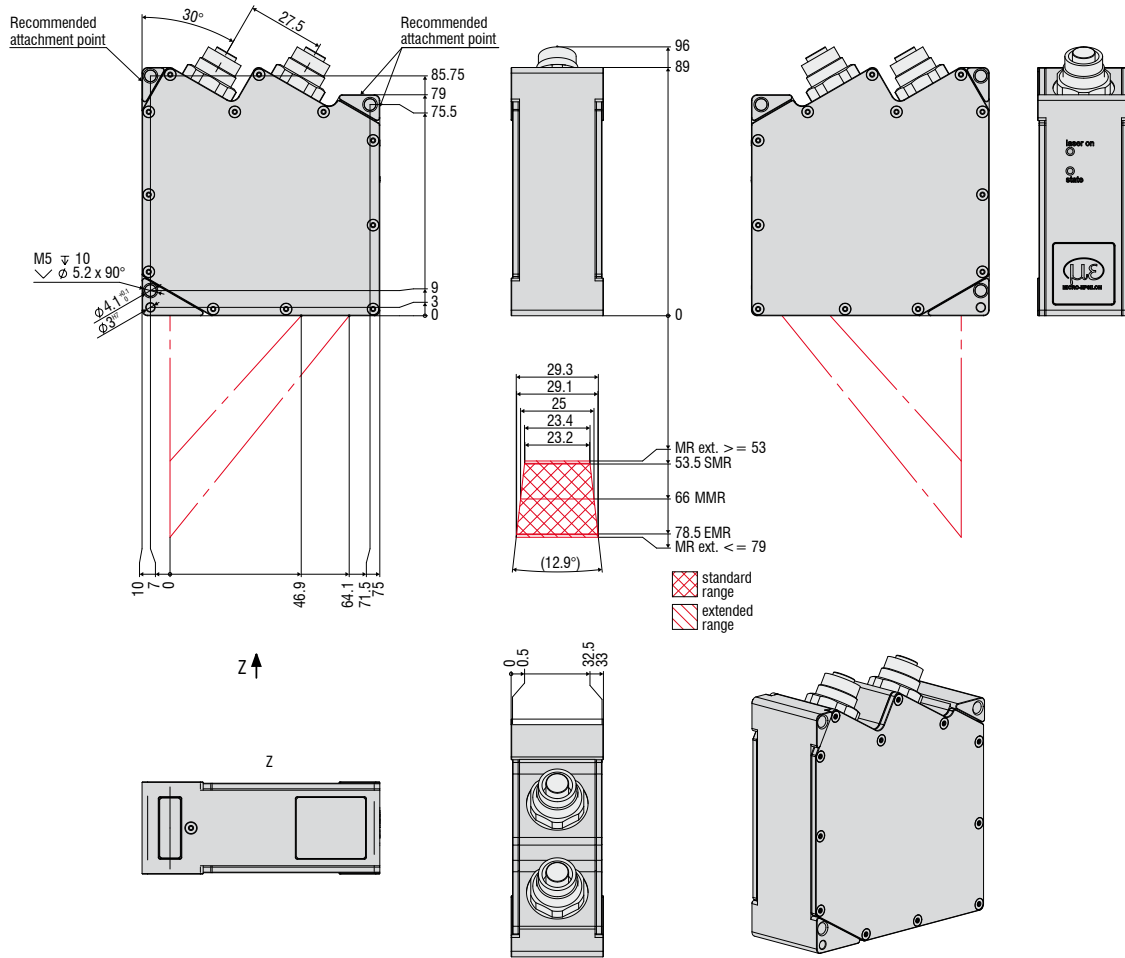

LLT25x0-50 / LLT29x0-50

Red Laser Blue Laser

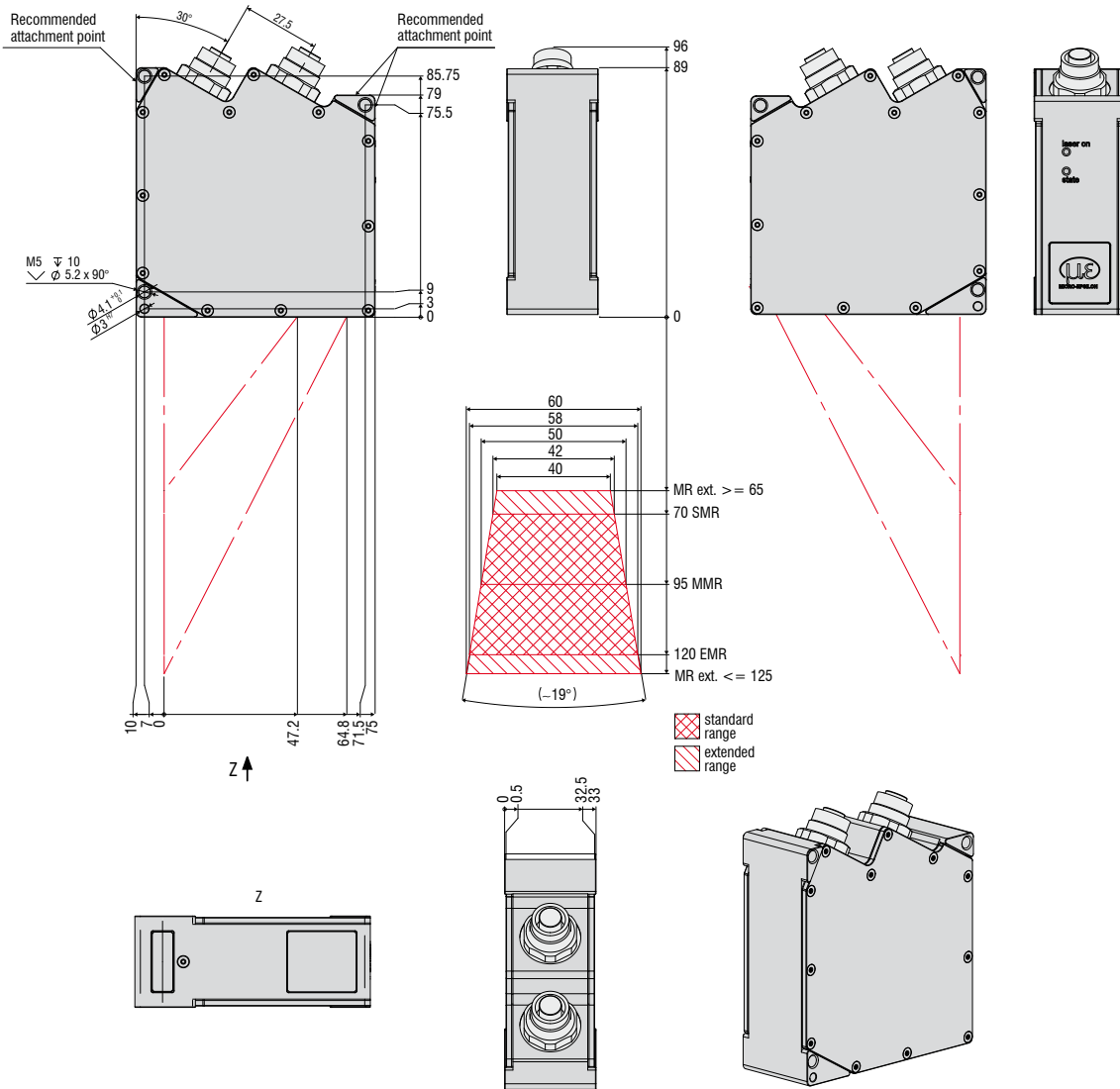

LLT25x0 -100 / LLT29x0-100

Red Laser Blue Laser

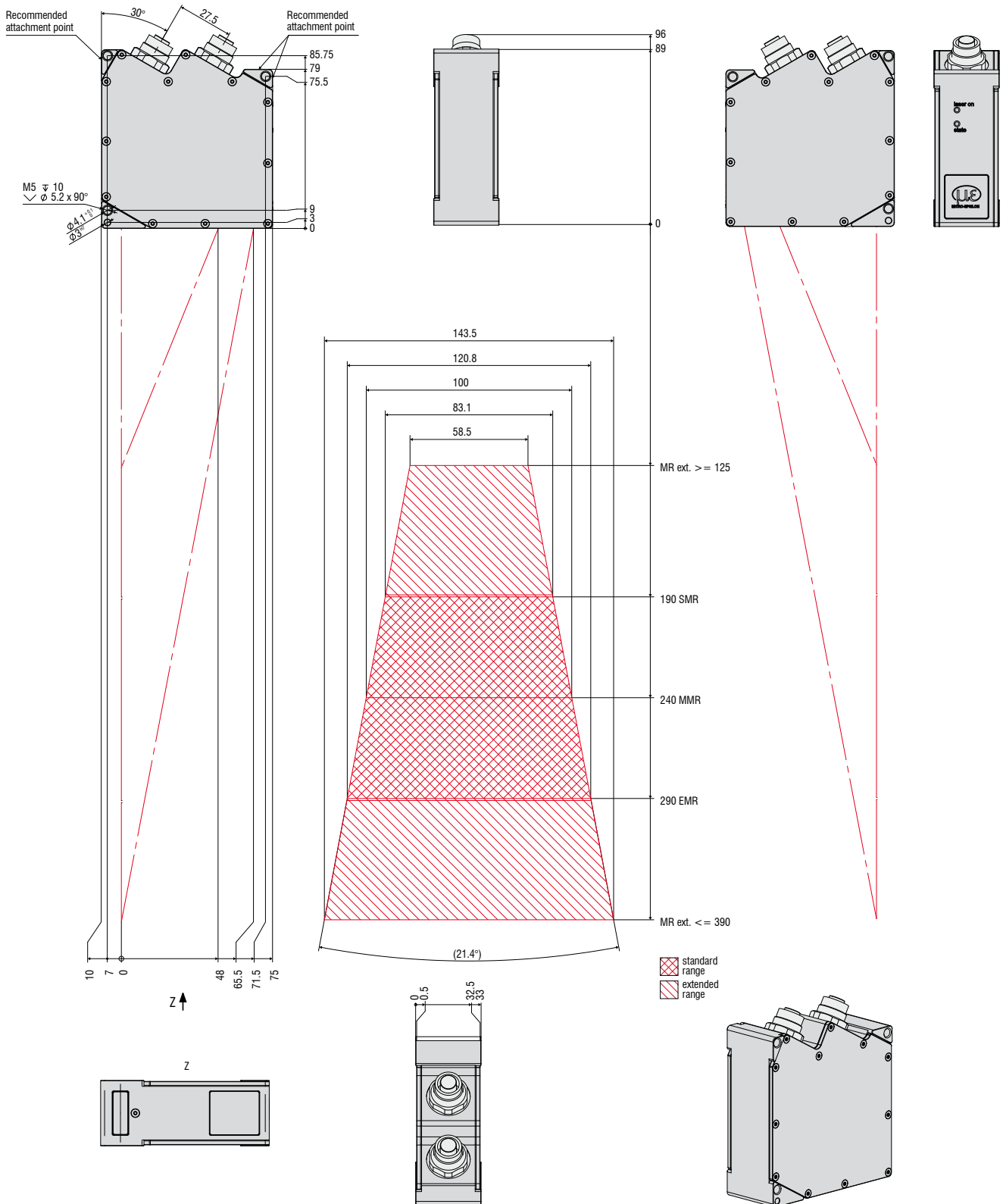



Precise profile measurements for industrial measurement tasks

Resolution (x-axis) 1,024 points

Profile frequency 5,000 Hz

For small and large measuring ranges

Also available with patented Blue Laser Technology

Precise 2D/3D profile measurements

The new LLT30x2 laser profile scanners provide calibrated profile data with up to 5.12 million points per second. They allow profile frequencies up to 5 kHz and resolutions up to 1,024 points. Thanks to their high accuracy and versatility, the scanners are particularly suitable for static and dynamic applications as well as robotic applications. They measure and evaluate, e. g., angles, steps, gaps, distances, and circles.

Available as COMPACT and SMART versions

The scanCONTROL 30x2 series is available as COMPACT and SMART versions. The COMPACT scanners provide calibrated profile data that can be further processed on a PC with software evaluation provided by the customer. SMART scanners operate autonomously and provide selected measurement values. The scanCONTROL 30x2 series supports all SMART functions and programs that are set in the scanCONTROL Configuration Tools software and directly stored in the internal controller.

The easy way of machine integration

The design of the LLT30x2 series is compact and lightweight. The controller is integrated in the sensor itself, which simplifies mechanical integration. The measurement data can be output directly.

Article designation

LLT	30	xx	-25	/SI	
Options - see below					
Measuring range					
25 mm					
50 mm					
100 mm					
200 mm					
Class					
02 = COMPACT					
12 = SMART					
Series					
LLT30xx					

Laser options*

	/SI	Hardware switch-off of the laser line
	/3R	Increased laser power (class 3R) e.g., for dark surfaces
	/BL	Blue laser line (405 nm) for (semi-) transparent, red-hot glowing and organic materials

Cable output options*

	/PT	Cable directly out of the sensor ("Pigtail") Available lengths: 0.3 / 0.6 / 1 m
--	-----	--

*Options can be combined

Model		LLT 30x2-25	LLT 30x2-50	LLT 30x2-100	LLT 30x2-200	
Available laser type		Red Laser Blue Laser	Red Laser Blue Laser	Red Laser Blue Laser	Red Laser	
Z-axis	Measuring range	Start of measuring range	77.5 mm	105 mm	200 mm	200 mm
		Mid of measuring range	85 mm	125 mm	270 mm	310 mm
		End of measuring range	92.5 mm	145 mm	340 mm	420 mm
		Height of measuring range	15 mm	40 mm	140 mm	220 mm
	Extended measuring range	Start of measuring range	-	-	190 mm	160 mm
		End of measuring range	-	-	360 mm	460 mm
Line linearity ^{1) 2)}		2 μm	4 μm	10 μm	30 μm	
		±0.013 %	±0.01 %	±0.007 %	±0.014 %	
X-axis	Measuring range	Start of measuring range	23 mm	43.3 mm	75.6 mm	130 mm
		Mid of measuring range	25 mm	50 mm	100 mm	200 mm
		End of measuring range	26.8 mm	56.5 mm	124.4 mm	270 mm
	Extended measuring range	Start of measuring range	-	-	72.1 mm	100 mm
		End of measuring range	-	-	131.1 mm	290 mm
Resolution		1,024 points/profile				
Profile frequency		up to 5,000 Hz				
Interfaces	Ethernet GigE Vison	Output of measurement values Sensor control Profile data transmission				
	Digital inputs	Mode switching Encoder (counter) Trigger				
	RS422 (half-duplex) ³⁾	Output of measurement values Sensor control Trigger Synchronization				
Output of measurement values		Ethernet (UDP / Modbus TCP); RS422 (ASCII / Modbus RTU) analog ⁴⁾ ; switch signal ⁴⁾ PROFINET ⁵⁾ ; EtherCAT ⁵⁾ ; EtherNet/IP ⁵⁾				
Control and display elements		3x color LEDs for laser, data and error				
Light source		≤ 10 mW		≤ 12 mW		
		Standard: laser class 2M, semiconductor laser 658 nm				
	Red Laser	≤ 30 mW		≤ 50 mW		
		Option: laser class 3R, semiconductor laser 658 nm				
	Blue Laser	≤ 10 mW		-		
	Standard: laser class 2M, semiconductor laser 405 nm					
	Laser switch-off	via software, hardware switch-off with /SI option				
Aperture angle of laser line		23°	28°	30°	45°	
Permissible ambient light (fluorescent light) ¹⁾		10,000 lx				
Protection class (DIN EN 60529)		IP67 (when connected)				
Vibration (DIN EN 60068-2-27)		2 g / 20 ... 500 Hz				
Shock (DIN EN 60068-2-6)		15 g / 6 ms				
Temperature range	Storage	-20 ... +70 °C				
	Operation	0 ... +45 °C				
Weight		415 g (without cable)				
Supply voltage		11 ... 30 VDC, nominal value 24 V, 500 mA, IEEE 802.3af class 2, Power over Ethernet (PoE)				

¹⁾ According to measuring range; Measuring object: Micro-Epsilon standard object

²⁾ According to a one-time averaging over the width of the measuring field (1,024 points)

³⁾ RS422 interface, programmable either as serial interface or as input for triggering/synchronization

⁴⁾ Only with 2D/3D Output Unit

⁵⁾ Only with 2D/3D Gateway



High resolution in x- and z-axis for accurate profile measurement

Profile frequency up to 10 kHz for monitoring of dynamic processes

Innovative exposure control

For small and large measuring ranges

Also available with patented Blue Laser Technology

Fast and precise 2D/3D profile measurements

The new LLT30x0 laser profile scanners provide calibrated profile data with up to 7.37 million points per second. Thanks to their high accuracy, high profile frequency and versatility, these powerful scanners are suitable for demanding measurement tasks. They measure and evaluate, e.g., angles, steps, gaps, distances and circles with high precision. These sensors also offer predefined operating modes that enable optimal results for various applications.

Available as COMPACT and SMART versions

The scanCONTROL 30x0 series is available as COMPACT and SMART versions. The COMPACT scanners provide calibrated profile data that can be further processed on a PC with software evaluation provided by the customer. SMART scanners operate autonomously and provide selected measurement values. The scanCONTROL 30x0 series supports all SMART functions and programs that are set in the scanCONTROL Configuration Tools software and directly stored in the internal controller.

Innovative exposure control to master difficult surfaces

On inhomogeneous or dark surfaces, the HDR (High Dynamic Range) data acquisition mode and the improved auto exposure optimizes the measurement results. In HDR mode, the rows of the sensor matrix are exposed differently but at the same time which avoids time offsets between the recordings. This is how moving objects can be detected reliably. The areas for auto exposure can be selected individually.

Article designation

LLT	30	xx	-25	/SI	
Options - see below					
Measuring range					
25 mm					
50 mm					
100 mm					
200 mm					
Class					
00 = COMPACT					
10 = SMART					
Series					
LLT30xx					

Laser options*

	/SI	Hardware switch-off of the laser line
	/3R	Increased laser power (class 3R) e.g., for dark surfaces
	/BL	Blue laser line (405 nm) for (semi-) transparent, red-hot glowing and organic materials

Cable output options*

	/PT	Cable directly out of the sensor ("Pigtail") Available lengths: 0.3 / 0.6 / 1.00 m
--	-----	---

*Options can be combined

Model		LLT 30x0-25	LLT 30x0-50	LLT 30x0-100	LLT 30x0-200	
Available laser type		Red Laser Blue Laser	Red Laser Blue Laser	Red Laser Blue Laser	Red Laser	
Z-axis	Measuring range	Start of measuring range	77.5 mm	105 mm	200 mm	200 mm
		Mid of measuring range	85 mm	125 mm	270 mm	310 mm
		End of measuring range	92.5 mm	145 mm	340 mm	420 mm
		Height of measuring range	15 mm	40 mm	140 mm	220 mm
	Extended measuring range	Start of measuring range	-	-	190 mm	160 mm
		End of measuring range	-	-	360 mm	460 mm
Linearity ¹⁾²⁾		1.5 μm	3 μm	9 μm	26 μm	
		±0.01 %	±0.0075 %	±0.006 %	±0.012 %	
X-axis	Measuring range	Start of measuring range	23 mm	43.3 mm	75.6 mm	130 mm
		Mid of measuring range	25 mm	50 mm	100 mm	200 mm
		End of measuring range	26.8 mm	56.5 mm	124.4 mm	270 mm
	Extended measuring range	Start of measuring range	-	-	72.1 mm	100 mm
		End of measuring range	-	-	131.1 mm	290 mm
Resolution		2,048 points/profile				
Profile frequency		up to 10,000 Hz				
Interfaces	Ethernet GigE Vison	Output of measurement values Sensor control Profile data transmission				
	Digital inputs	Mode switching Encoder (counter) Trigger				
	RS422 (half-duplex) ³⁾	Output of measurement values Sensor control Trigger Synchronization				
Output of measurement values		Ethernet (UDP / Modbus TCP); RS422 (ASCII / Modbus RTU) analog ⁴⁾ ; switch signal ⁴⁾ PROFINET ⁵⁾ ; EtherCAT ⁵⁾ ; EtherNet/IP ⁵⁾				
Control and display elements		3x color LEDs for laser, data and error				
Light source		≤ 10 mW		≤ 12 mW		
	Red Laser	Standard: laser class 2M, semiconductor laser 658 nm				
		≤ 30 mW		≤ 50 mW		
	Blue Laser	Option: laser class 3R, semiconductor laser 658 nm				
		≤ 10 mW		-		
		Standard: laser class 2M, semiconductor laser 405 nm				
	Laser switch-off	via software, hardware switch-off with /SI option				
Aperture angle of laser line		23°	28°	30°	45°	
Permissible ambient light (fluorescent light) ¹⁾		10,000 lx				
Protection class (DIN EN 60529)		IP67 (when connected)				
Vibration (DIN EN 60068-2-27)		2 g / 20 ... 500 Hz				
Shock (DIN EN 60068-2-6)		15 g / 6 ms				
Temperature range	Storage	-20 ... +70 °C				
	Operation	0 ... +45 °C				
Weight		415 g (without cable)				
Supply voltage		11 ... 30 VDC, nominal value 24 V, 500 mA, IEEE 802.3af class 2, Power over Ethernet (PoE)				

¹⁾ According to measuring range; Measuring object: Micro-Epsilon standard object

²⁾ According to a one-time averaging over the width of the measuring field (2,048 points)

³⁾ RS422 interface, programmable either as serial interface or as input for triggering/synchronization

⁴⁾ Only with 2D/3D Output Unit

⁵⁾ Only with 2D/3D Gateway

LLT30x2-25 / LLT30x0-25

Red Laser

Blue Laser

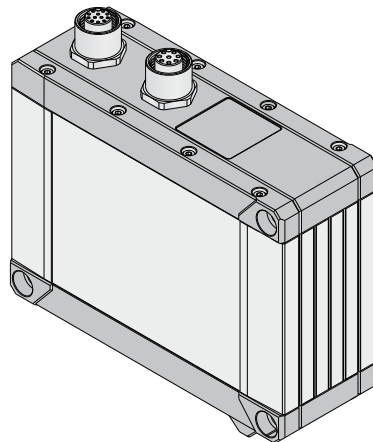
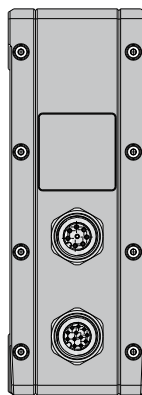
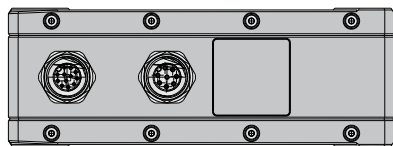
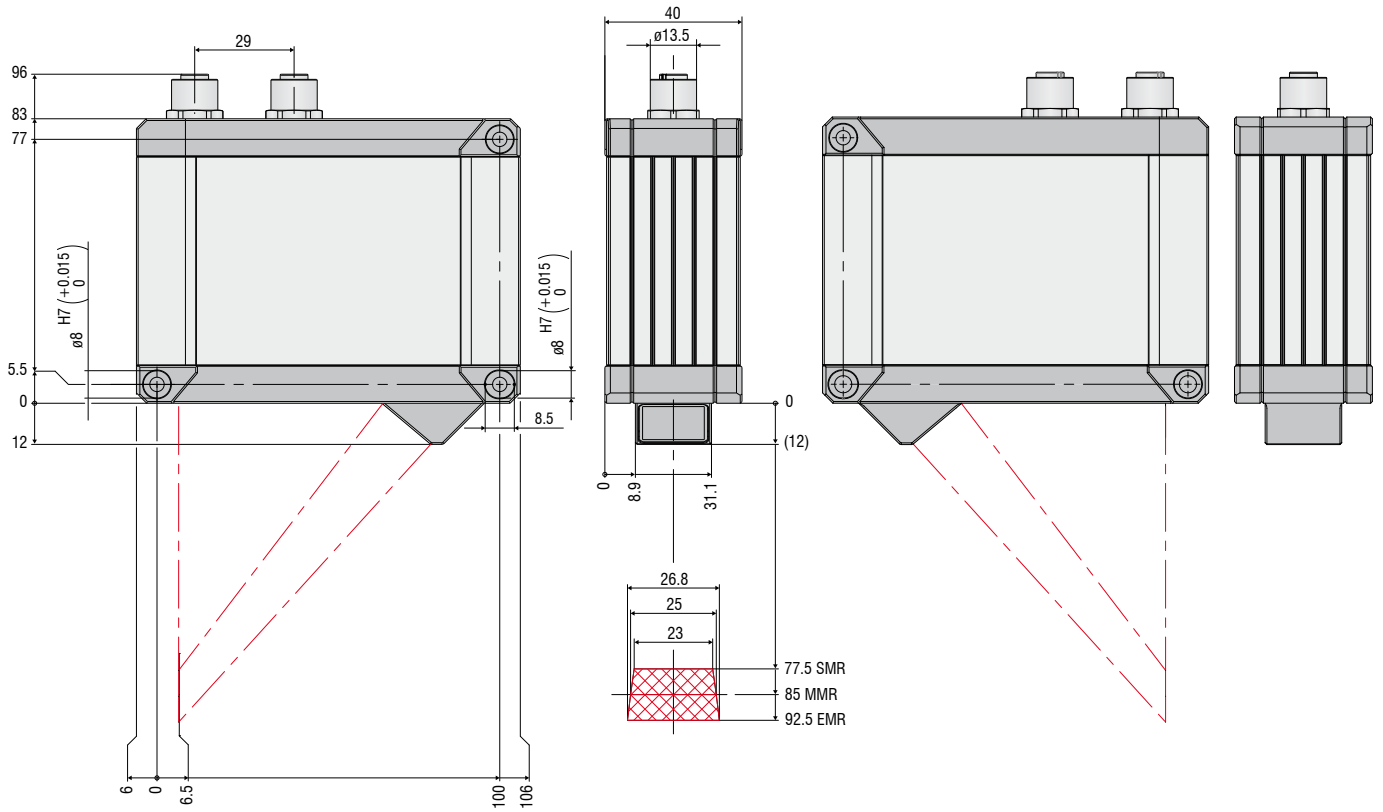

LLT30x2-50 / LLT30x0-50

Red Laser Blue Laser

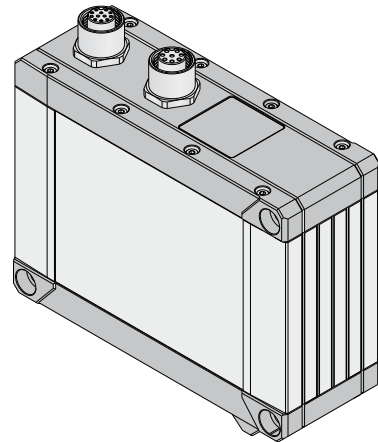
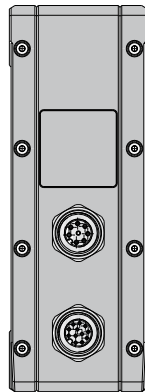
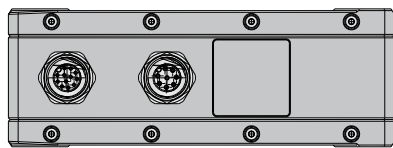
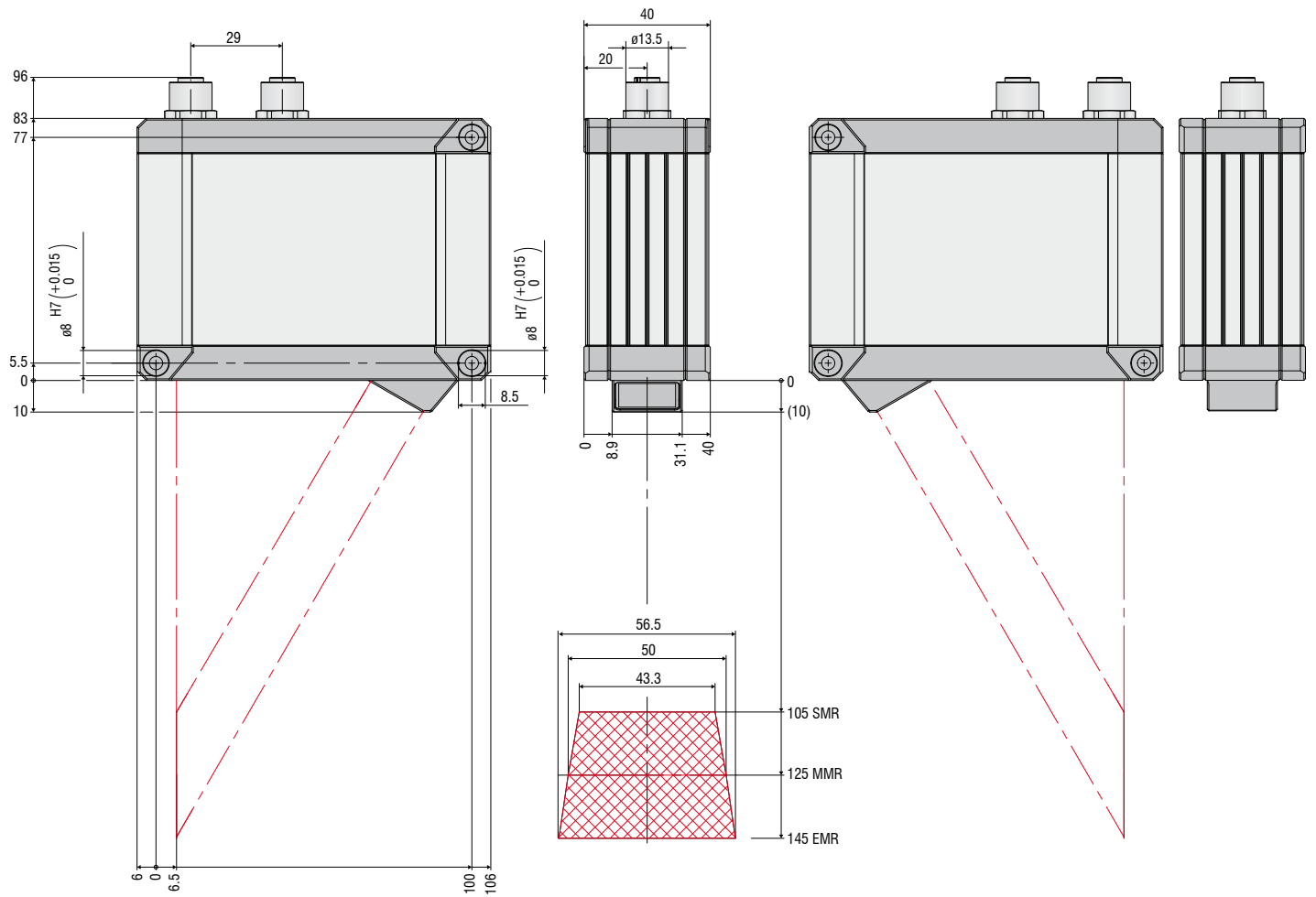

LLT30x2-100 / LLT30x0-100

Red Laser Blue Laser

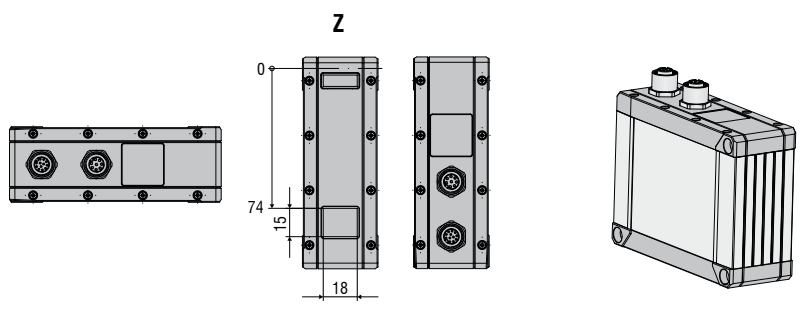
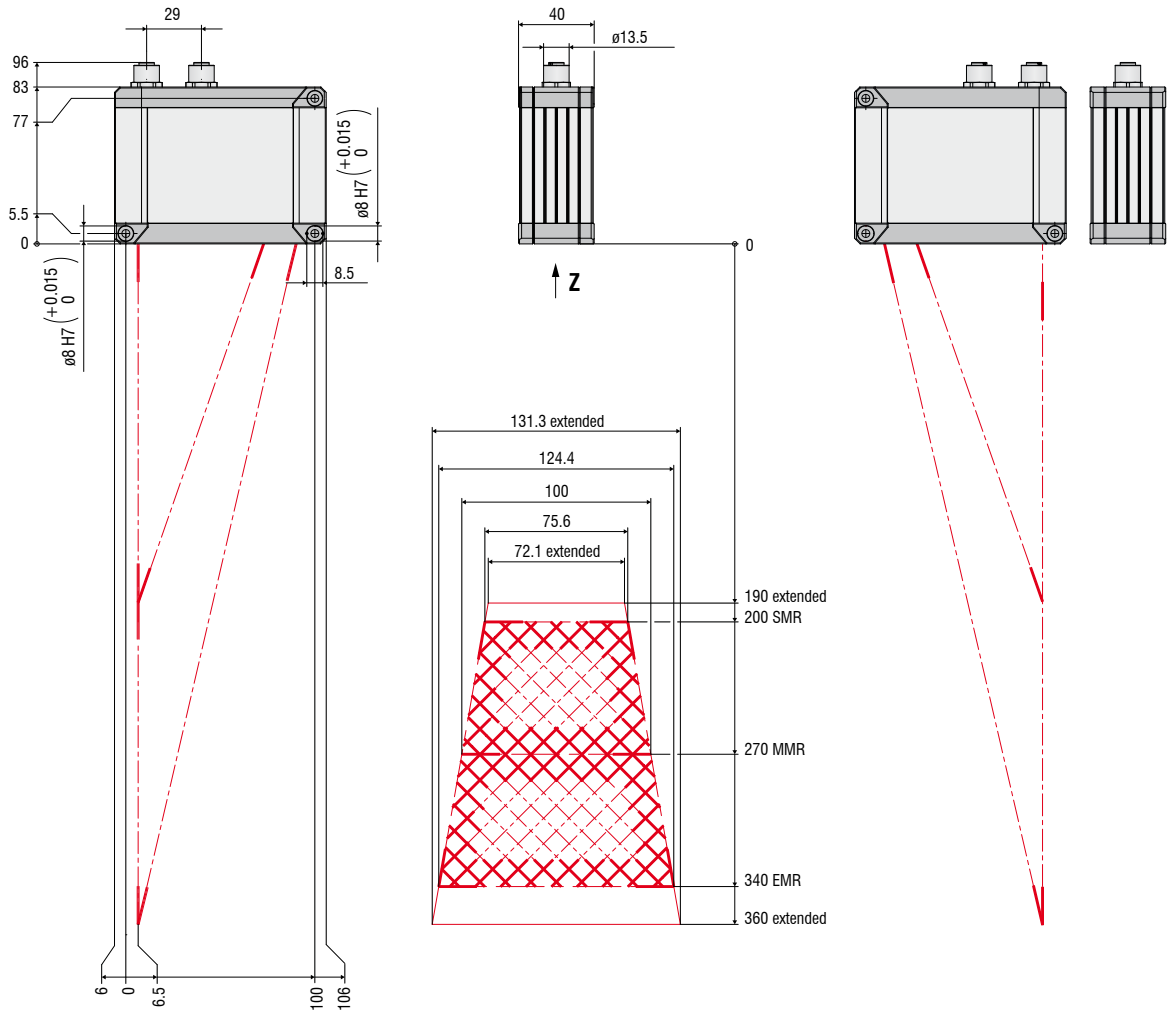

LLT30x2-200 / LLT30x0-200

Red Laser

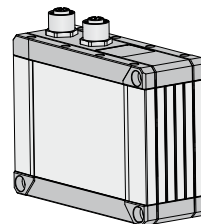
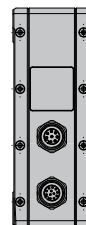
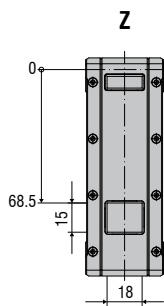
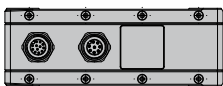
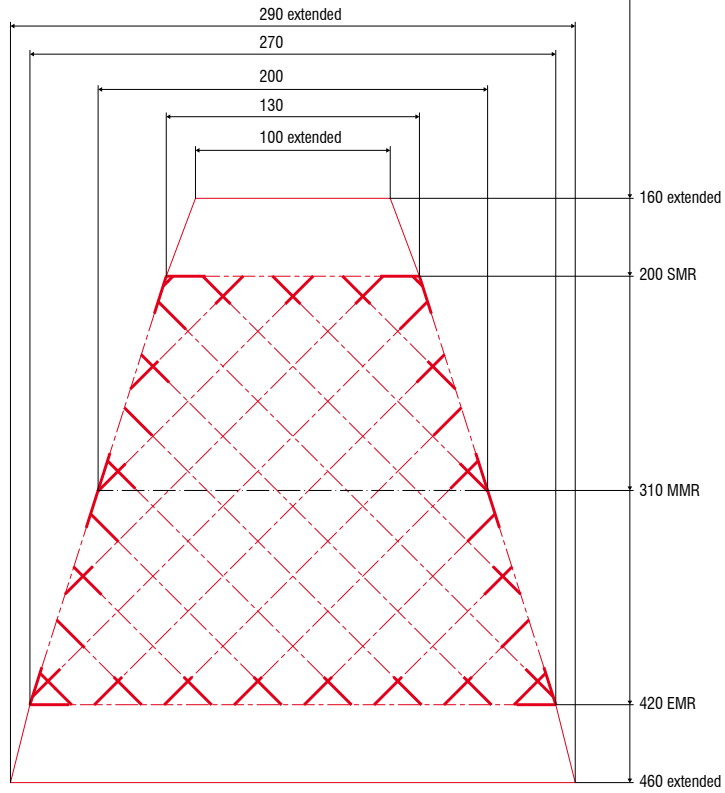
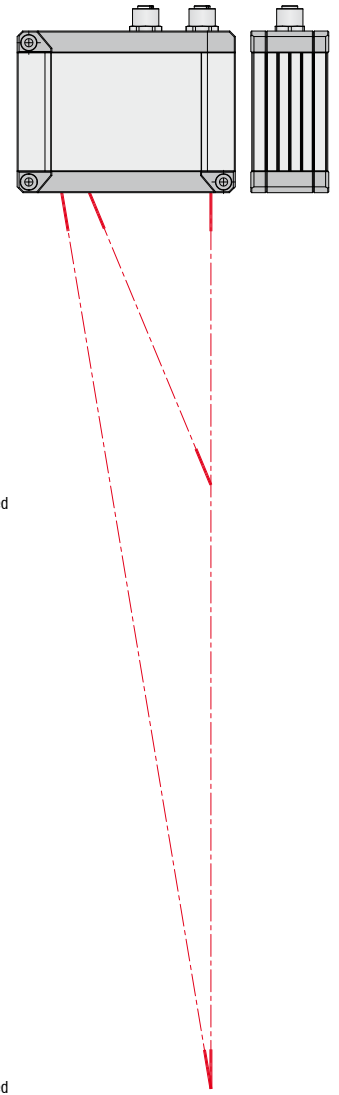
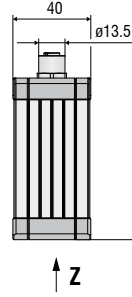
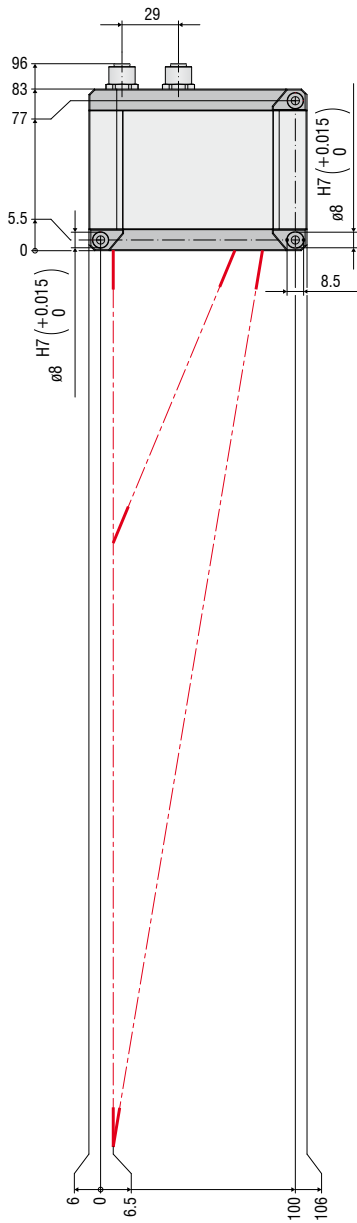



Plug & Play solution for complex measurement tasks

Evaluation directly in the sensor without external controller

Parallel execution of different measurement tasks and multiple evaluation

Easy online and offline analysis

scanCONTROL SMART sensors have an integrated intelligent controller for easy profile evaluation without requiring an additional PC. Configuration and parameter setup of the sensor is via the scanCONTROL Configuration Tools software. It enables sensor setup, viewing of profiles, as well as saving, loading and exporting profiles. All software functions can also be executed without a sensor in order to test the measurement task offline for very fast processes.



Download:
[micro-epsilon.com/
 2D_3D/laser-scanner/
 Software/downloads/](http://micro-epsilon.com/2D_3D/laser-scanner/Software/downloads/)

Easy 5-Step Configuration

1.

Alignment of the sensor



2.

Configuring the sensor

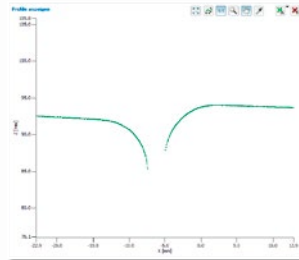

The software enables the user to completely configure the scanner in just five simple steps. After configuration, the scanner is in standalone mode and transmits the measured values to a PLC.

3.

Selection of measurement programs



4.

Configuring the measurement programs

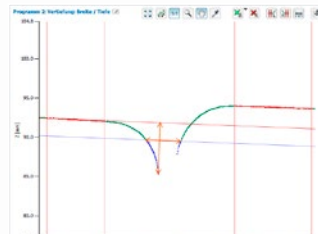

5.

Output and display of measured values



Numerous Setting Options

- 8 measuring programs x 8 evaluations per parameter set
- 15 independent parameter packages can be stored in the sensor
- Unlimited memory for parameter sets on the computer

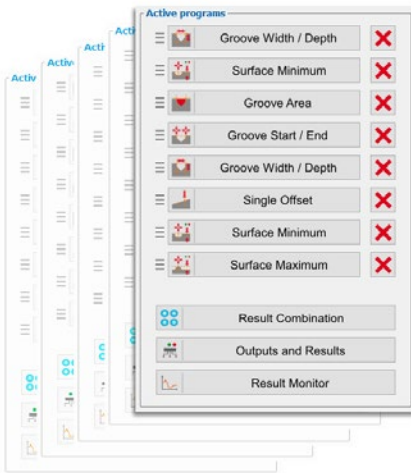

Wide Range of Measurement Tools

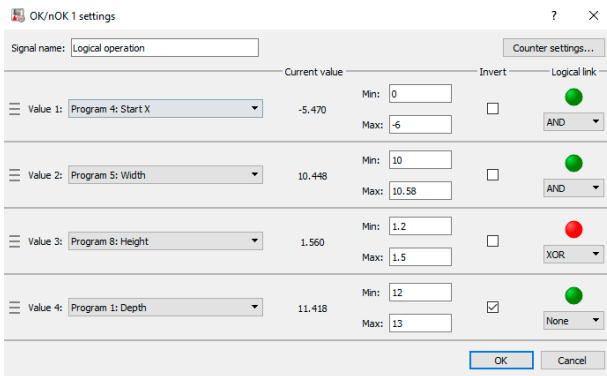
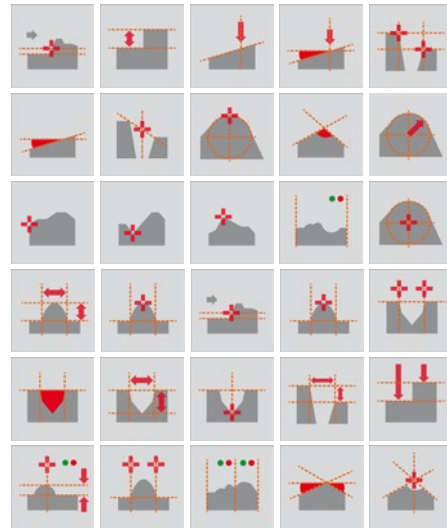

Logical Links

- Combined query of different conditions
- Summarized result evaluation in the sensor as OK/NOK

scanCONTROL Result Monitor

Result Monitor is a new software tool for displaying measured values of up to 4 SMART sensors.

- Display of profile and measured value history
- Different views, e.g., for workers
- Parallel transmission of the measured values to the control unit is possible and recommended
- Ring buffer logging and memory
- Adjustable layout



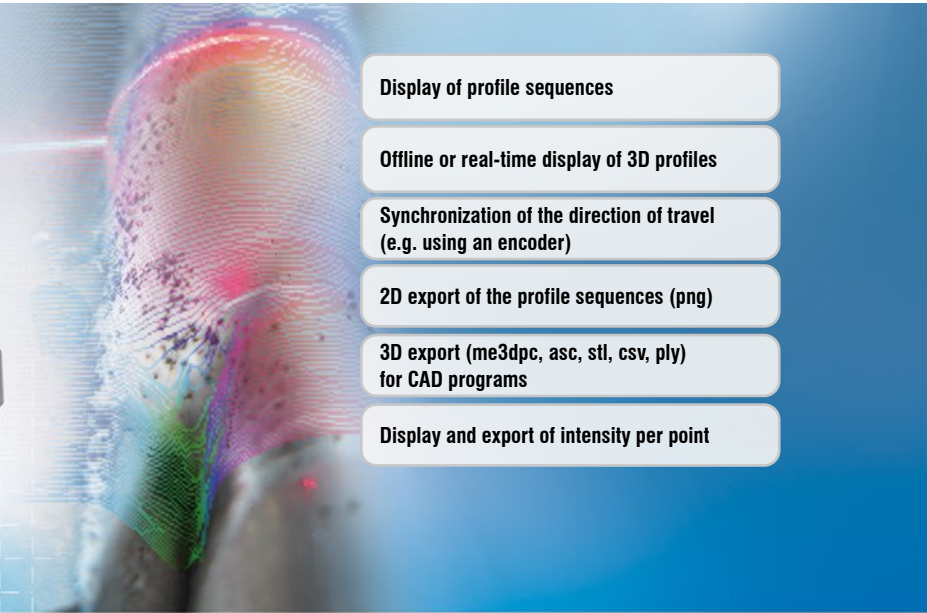

Display of profile sequences

Offline or real-time display of 3D profiles

Synchronization of the direction of travel (e.g. using an encoder)

2D export of the profile sequences (png)

3D export (me3dpc, asc, stl, csv, ply) for CAD programs

Display and export of intensity per point

3D visualization for all scanCONTROL models

A third dimension of the measured data is obtained by a relative movement between sensor and target. The y-coordinates are assigned via a trigger or CMM counter.

The scanCONTROL 3D-View software is designed for viewing and exporting 3D data. In addition, 3D-View also supports the configuration of the sensor. The software enables the interactive viewing of 3D data and the export of this measurement data to common data formats. Different display modes, views and color coding simplify sensor setup and profile analysis. The software supports the online visualization of the profiles as well as offline analysis of stored profile sequences.



Download:
[micro-epsilon.com/
 2D_3D/laser-scanner/
 Software/downloads/](http://micro-epsilon.com/2D_3D/laser-scanner/Software/downloads/)

Different visualization options for better visibility of characteristics:

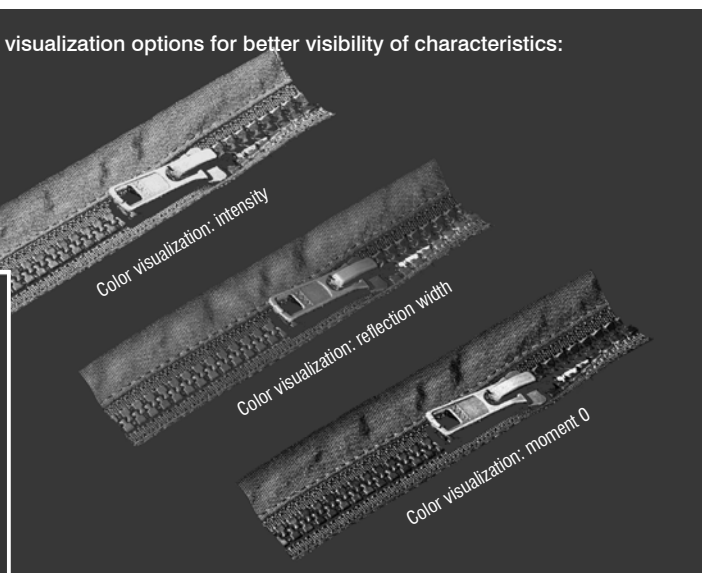
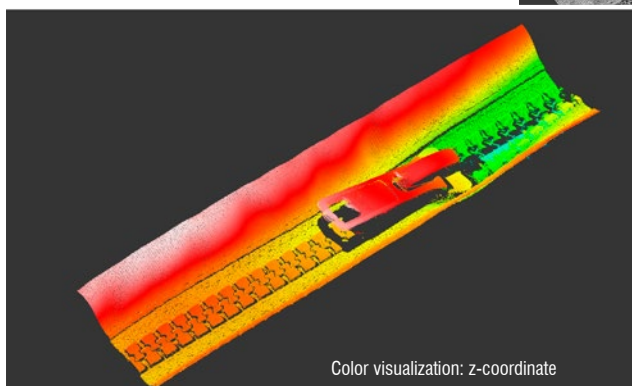

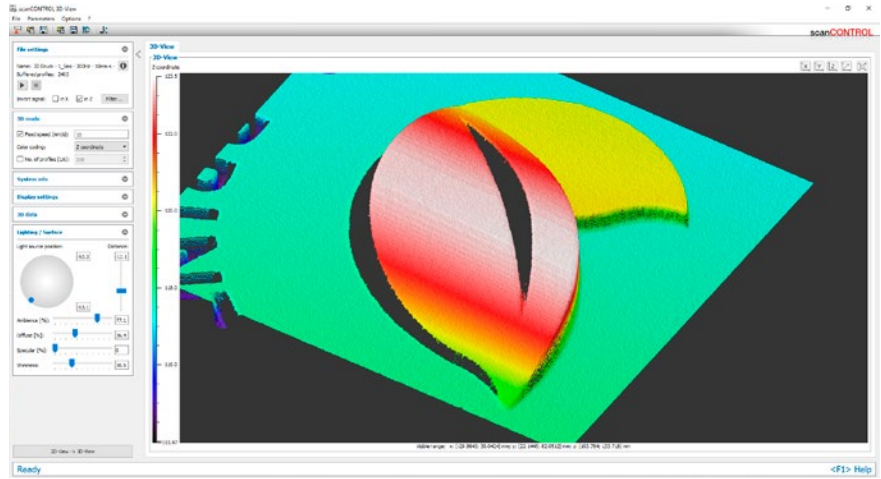
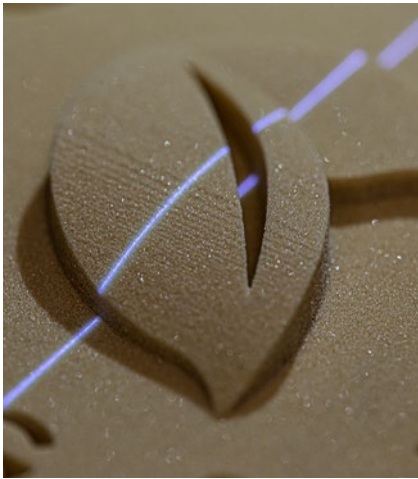

Scan (left) and 3D image of the scanned object (right)

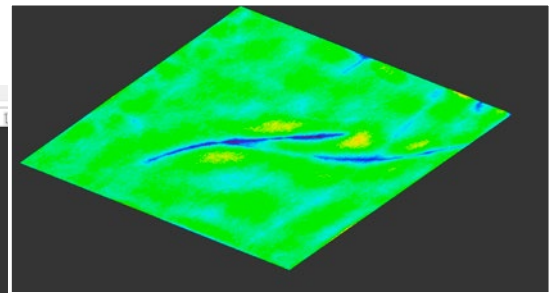
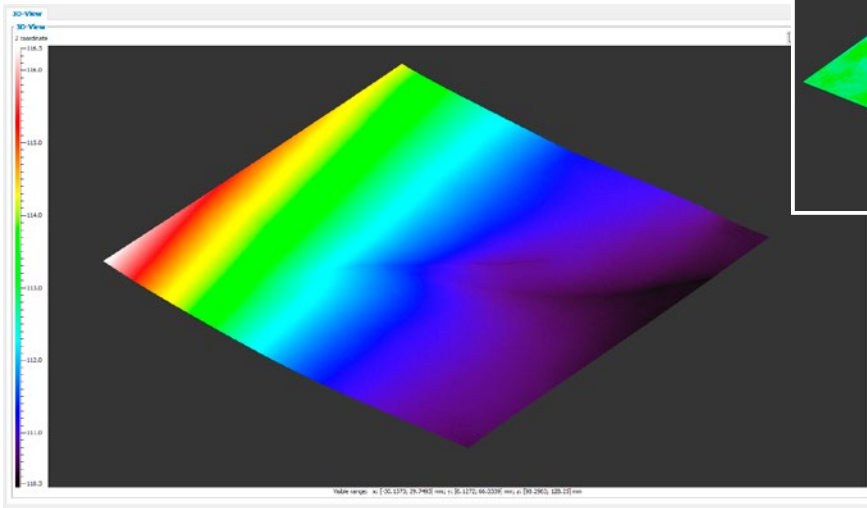

Fitting of a plane to make even the slightest unevenness on multiple-bent components visible.

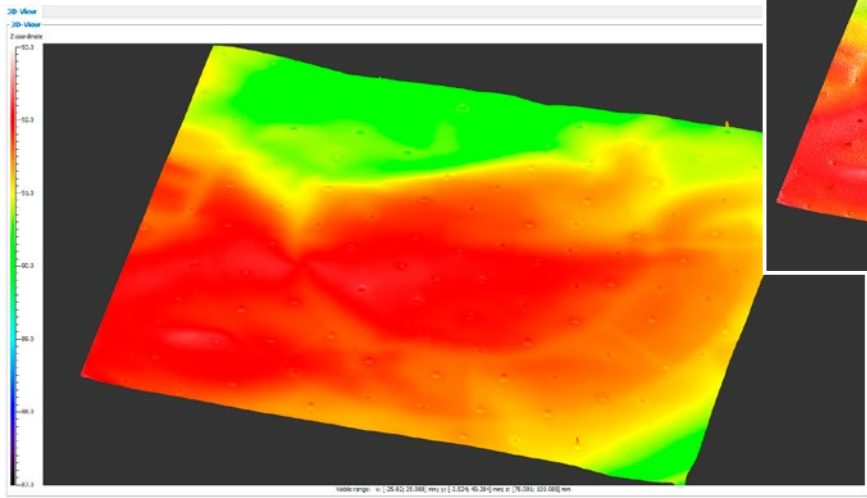

Different illumination options to highlight surface structures. With (left) and without illumination (right).

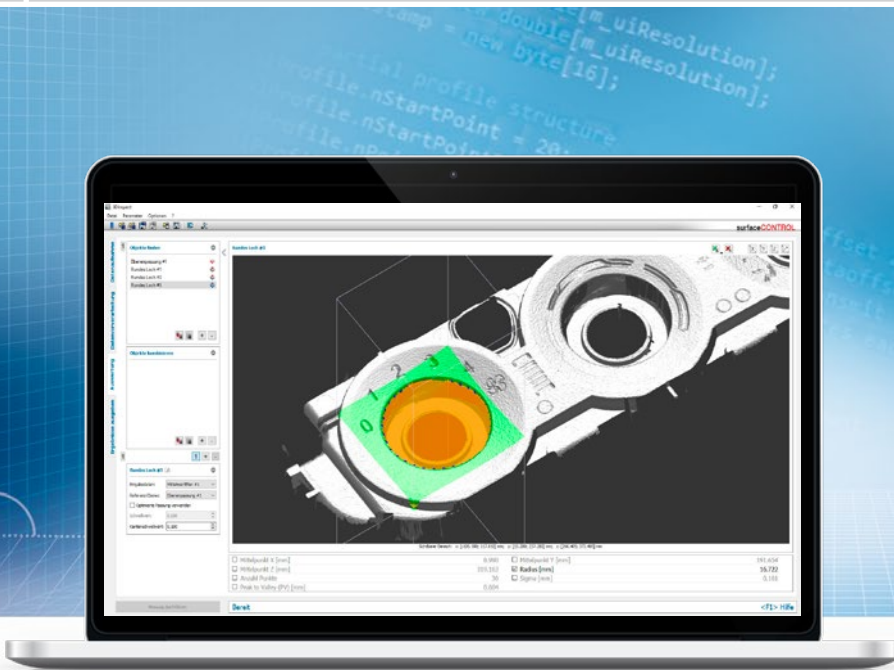

Intuitive user interface

Real 3D evaluation, not just 2.5D

Object extraction in 3D

Direct feedback with algorithms

Compatible with all 3D sensors
from Micro-Epsilon

3DInspect software for 3D measurement tasks and inspection

The 3DInspect software is a powerful tool for sensor parameter set up and industrial measurement tasks. This software transmits the measurement data from the sensor via Ethernet and provides the data in three-dimensional form. This 3D data is further processed, evaluated and assessed with 3DInspect measuring programs on the PC and, if necessary, logged and transmitted via Ethernet to a control unit. Furthermore, the software enables the storage of 3D data. In addition to the scanCONTROL 30xx models, the 3DInspect software is also supported by the surfaceCONTROL and reflectCONTROL sensors.

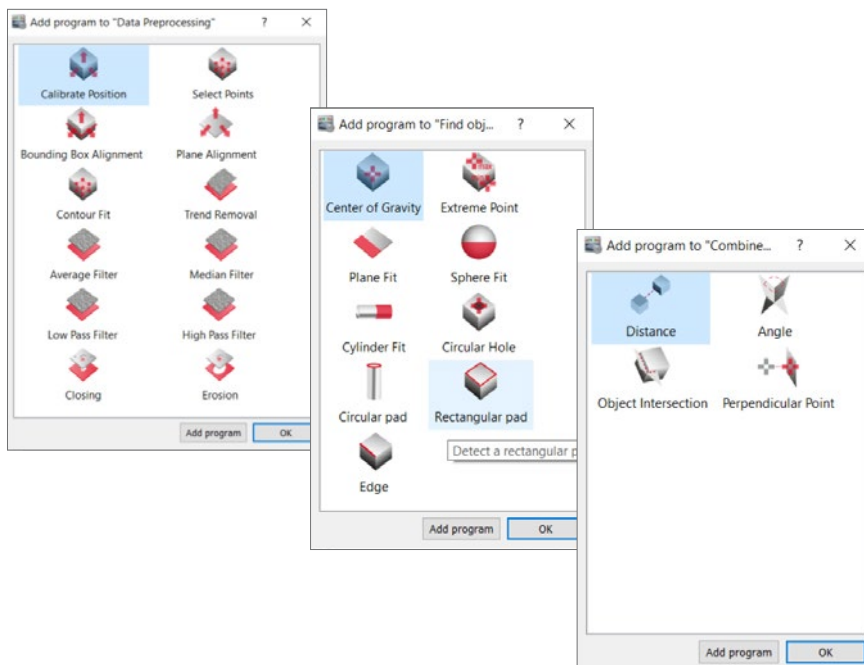

The pre-defined measuring software programs are divided into the categories "Data preprocessing", "Find objects" as well as in "Combine objects".

Valid3D technology from Micro-Epsilon vs. conventional 2.5D systems

The unique Valid3D technology enables lossless display and processing of the point clouds. This is how scanned 3D objects can be moved arbitrarily in the coordinate system.

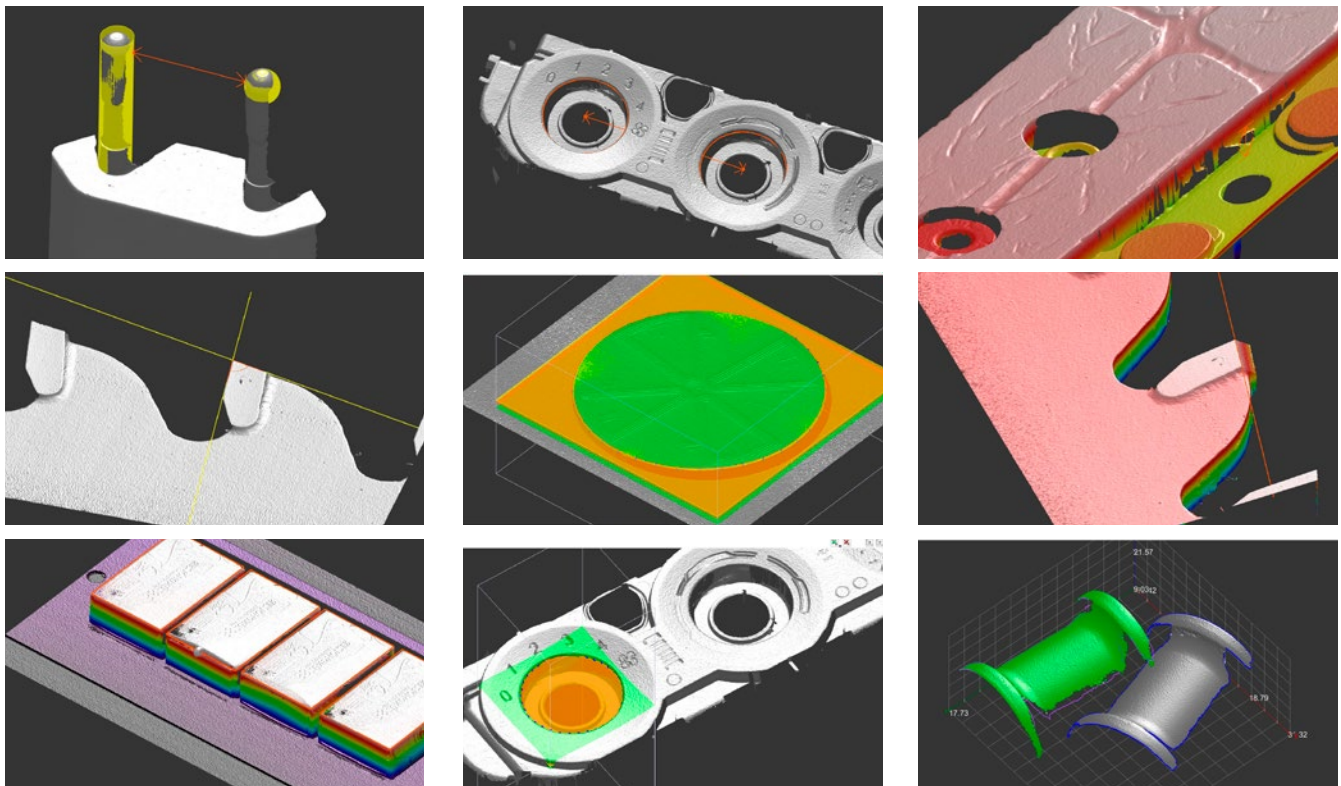
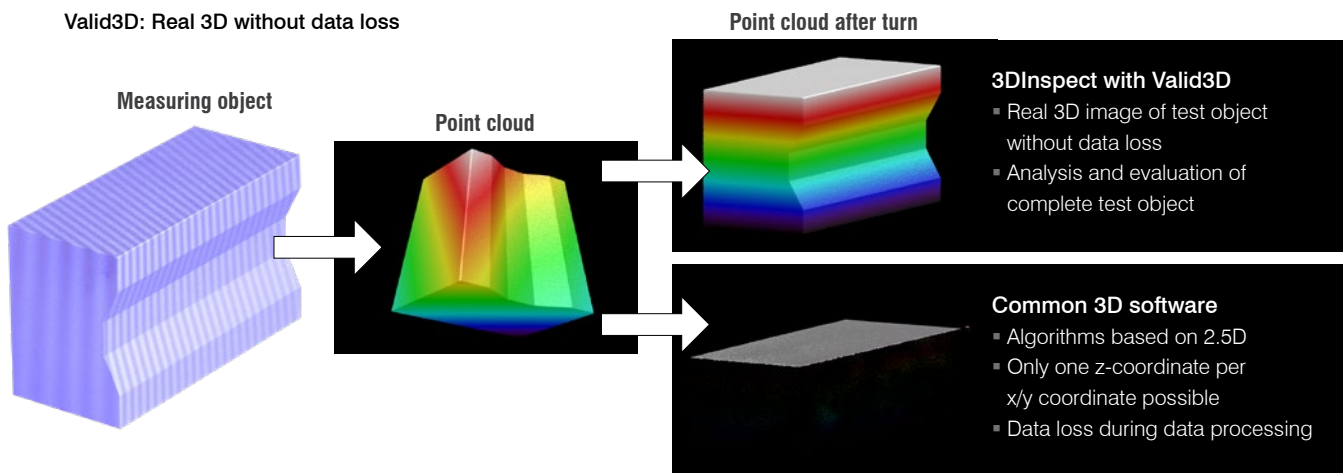



The scanCONTROL COMPACT sensors detect one profile from individual, calibrated points per measurement. Users can transfer these profiles to their own applications either individually or combined as an array/matrix in a container set. In addition to the data transfer of individual measuring points and their additional information (e.g. intensity, counter reading) the entire configuration of the sensor can also be controlled from its own application software.

Micro-Epsilon provides a number of interfaces to access the parameter and data transfer functions. The transmission interface primarily used by scanCONTROL sensors for communications and profile transfer is Ethernet.

Ethernet and GigE Vision

Each scanCONTROL sensor complies with the GigE Vision Standard (Gigabit Ethernet for Machine Vision) of the AIA (Automated Imaging Association).

The standard is widely used in the image processing industry and is therefore supported by all conventional computer vision tools. This ensures fast and smooth integration into different image processing tools – also for 3D evaluation.

The GigE Vision standard stands for optimal data security, perfect performance and short implementation times. GigE Vision is based on Gigabit Ethernet and thus offers a high transfer rate. Ethernet technology offers advantages such as long cable lengths without using repeaters/hubs, and it permits the use of inexpensive network components. The GigE Vision standard provides an open framework for data transmission (e.g. profiles, data sets) and control signals between the laser scanner and a PC. Numerous infrastructure topology options are possible for single and multi-scanner applications.

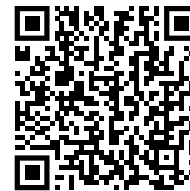

Download:
micro-epsilon.com/2D_3D/laser-scanner/Software/scanCONTROL-Integration/

GigE[®]
VISION



Profile acquisition

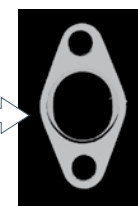

Grayscale image

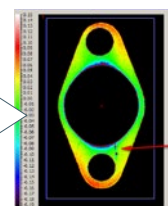

Image processing software

Integration with the C/C++ library

The C/C++ library for scanCONTROL supports both static and dynamic loading. Both stdcall and cdecl are supported as calling conventions. The individual functions of the library are clearly documented in the interface description and explained using examples.

The scanCONTROL SDK integration package includes:

- LLT.DLL library file
- Interfaces and scanCONTROL documentation
- Numerous programming examples for C++, Python, C# and Visual Basic (e.g. trigger, container mode)

The scanCONTROL Developer Tool demo program offers a complete integration example based on C++ for quick testing of the sensor configuration.

SetFeature ()

```
int
CLLTI.SetFeature(uint pLLT, uint Function, uint Value);
```

Setzen des Parameters einer Eigenschaft.

Parameter	Device Handle
pLLT	Registeradresse der Funktion (FEATURE)
Function	Zu schreibender Wert
Value	

Rückgabewert

Standard:
Spezifisch:
ERROR_SE
FEATURE

```
// Struct necessary for writing the partial profile
CLLTI::PartialProfile mPartialProfile;
double[] mValueX = new double[m_uResolution];
double[] mValueZ = new double[m_uResolution];
byte[] mbyTimestamp = new byte[16];
// Set the partial profile structure
mPartialProfile.nStartPoint = 20; // Offset 20 -> start at the 21th point of the profile
mPartialProfile.nStartPointData = 4; // Dataoffset 4 Bytes -> location of X and Z
mPartialProfile.nPointCount = m_uResolution / 2; // transmit half the resolution
mPartialProfile; // 4 Bytes -> X and Z (2 Bytes each)
// Allocate buffer
byte[] mbyProfile = new byte[mPartialProfile.nPointCount * mPartialProfile.nPointDataWidth];
// Set the partial profile
mPartialProfile.nPointCount = mbyProfile.Length;
Console.WriteLine("Writing Profile: " + mPartialProfile.nPointCount);
if (!((SetFeature (uint (Function), mbyProfile)) < CLLTI.GENERAL_FUNCTION_OK))
{
    OnError("Error: " + mPartialProfile.nPointCount);
    return false;
}
```

Integration with LabVIEW

The LabVIEW scanCONTROL instrument driver supports fast integration of scanCONTROL sensors into the LabVIEW application environment. For accessing a scanCONTROL sensor and its basic settings, users can drag-and-drop modules directly from the function palette into their VIs. Example VIs illustrating the scanCONTROL integration are also part of this package.

The integration of scanCONTROL sensors into the LabVIEW environment is based on the C/C++ library (LLT.DLL) of Micro-Epsilon. Detailed documentation also shows how to set up additional special sensor parameters.

The image shows a LabVIEW graphical user interface for the scanCONTROL instrument driver. It features a 'Profile Acquisition Parameters' dialog box with fields for 'Sensor ID', 'Serial Number', 'Measuring Field', 'Exposure Time (ms)', 'Max. Resolution (bits)', 'Profile', 'Acquisition Rate', 'Measuring Unit', 'Sensor ID', 'Serial Number', 'Profile per profile', 'Exposure time (ms)', and 'Max. Resolution (bits)'. Below the dialog are two data plots: the top one shows 'Resolution [bits]' vs 'Position [mm]' with a fluctuating line, and the bottom one shows 'Resolution [bits]' vs 'Position [mm]' with a smooth curve. To the right, a 'Function Palette' is visible with 'Instrument I/O' and 'Instrument Drivers' categories, including 'scanCONTROL' and 'scanCONTROL_2xxx'. Below the plots is a complex LabVIEW block diagram with various control and data flow blocks.

Integration with Linux

The integration into Linux is performed using an Open Source C library which has been extended with some important control features for scanCONTROL. An additional C++ library enables fast sensor integration of the entire functionality into a user-friendly API.

This library is based on the GeniCam standard which is why the sensor can be controlled either via GeniCam commands or directly via the control parameters listed in the documentation. For integration support (e.g. trigger, container mode), some example programs are also available.

Use on ARM embedded PCs (e.g. Raspberry Pi) is possible with restrictions.

The image displays a Linux environment. On the left, a GUI window shows a plot of 'Z Axis' vs 'X Axis' with a blue line forming a peak. Below the plot are status indicators: 'Profiles per sec [Hz]: 25.00', 'Profile number: 1749', 'Shutter time [ms]: 0.5', 'Lost profiles: 0', and 'Saturation [%]: -'. On the right, a terminal window shows the output of a program. The output includes: 'There are 2 scanCONTROL cameras', 'MICRO-EPSILON OptoScan Head-2000000', 'MICRO-EPSILON Head-2000000', 'The scanCONTROL is a scanCONTROL', 'Register callbacks', 'Show getting profiles via GeniCam', 'Start acquisition of profiles', '1: All profiles received in X/Z extracted!', 'X: -26.91 Z: 86.16448', 'Profile Count: 82915 Success: 82915 Success: 82915', and 'Disconnect'. The terminal prompt is 'pi@raspberrypi ~/llt/linux'.

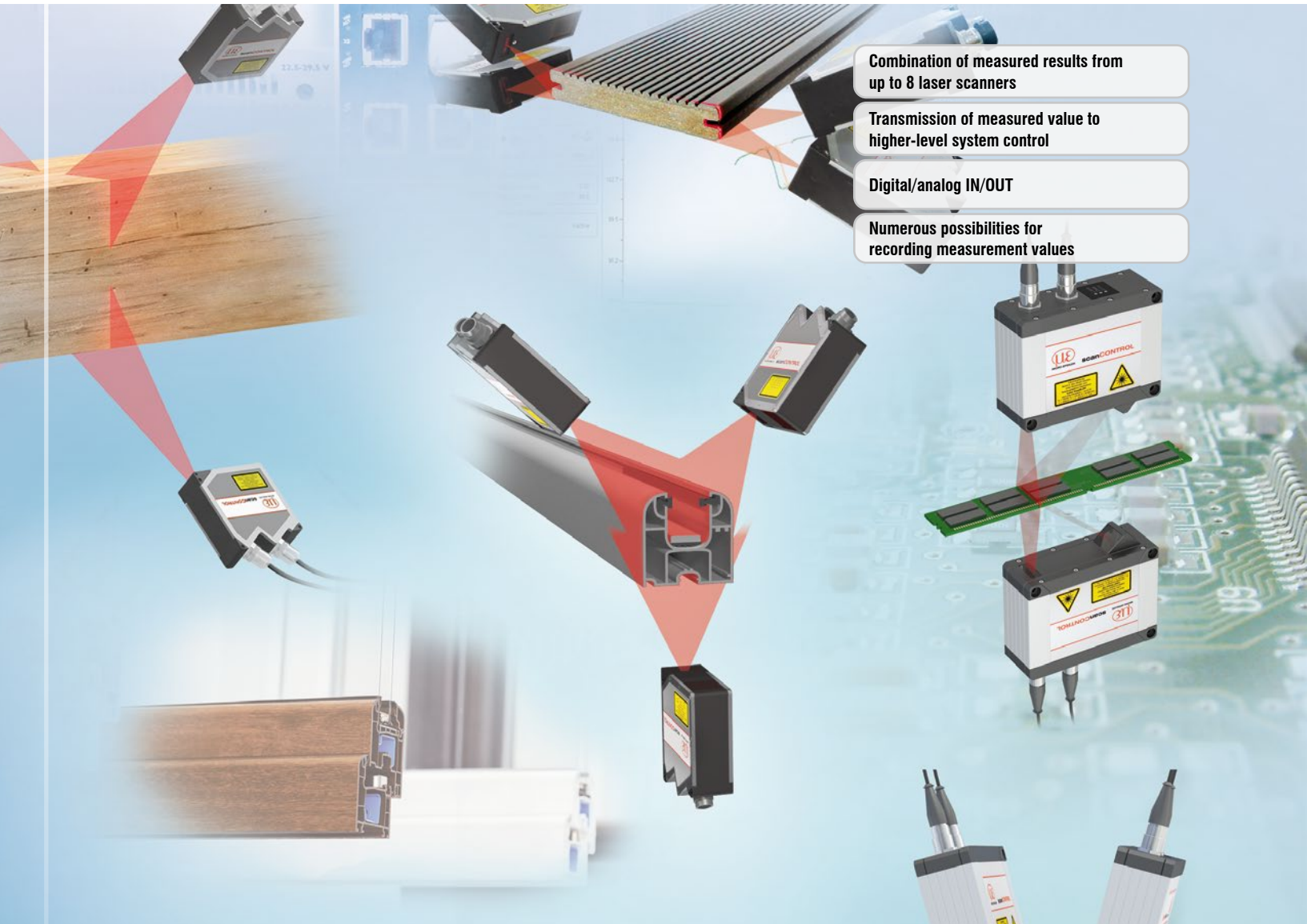

- Combination of measured results from up to 8 laser scanners
- Transmission of measured value to higher-level system control
- Digital/analog IN/OUT
- Numerous possibilities for recording measurement values

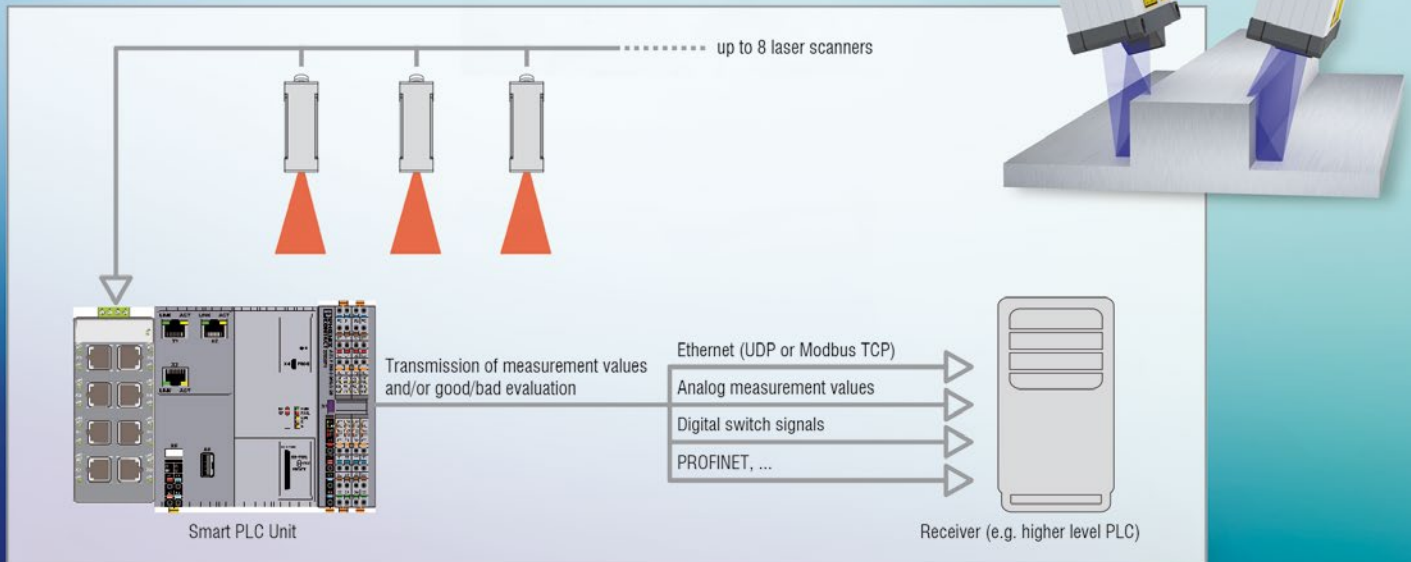

Measurement tasks such as contour measurement or the scanning of large components require the use of several scanners. The scanCONTROL Smart PLC Unit is an industrial control unit that includes tailor-made application software for the combination of measurement values from scanCONTROL SMART laser scanners.

It evaluates and logs the measured values in order to transmit them to the higher-level control system. For this purpose, analog and digital interfaces as well as numerous fieldbus connections (e.g. Profinet, Ethernet IP, EtherCAT) are available. The modular design of the Smart PLC Unit enables the user to connect up to 8 laser scanners.

Application examples:

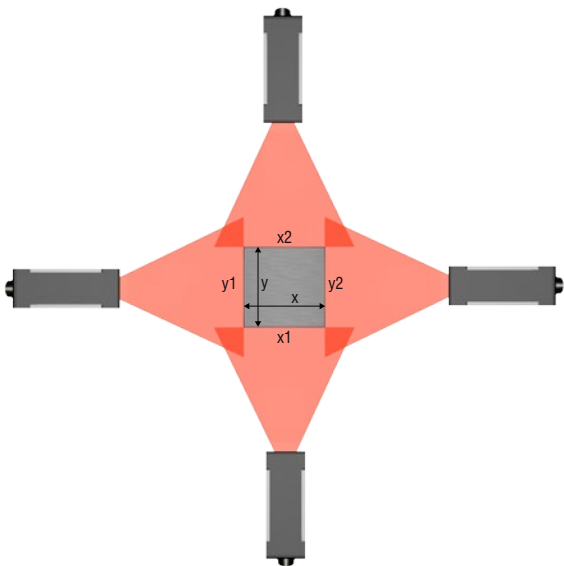

Determination of cross-section in the extrusion process

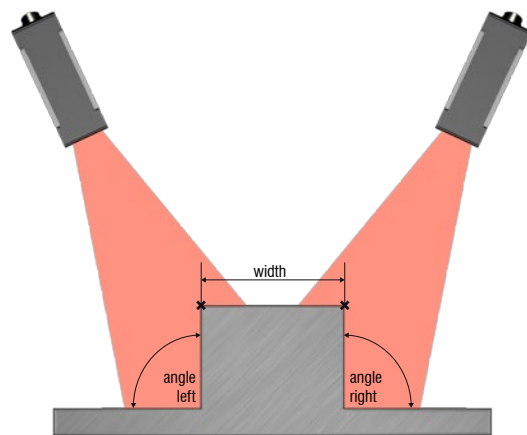

Contour measurement of a land

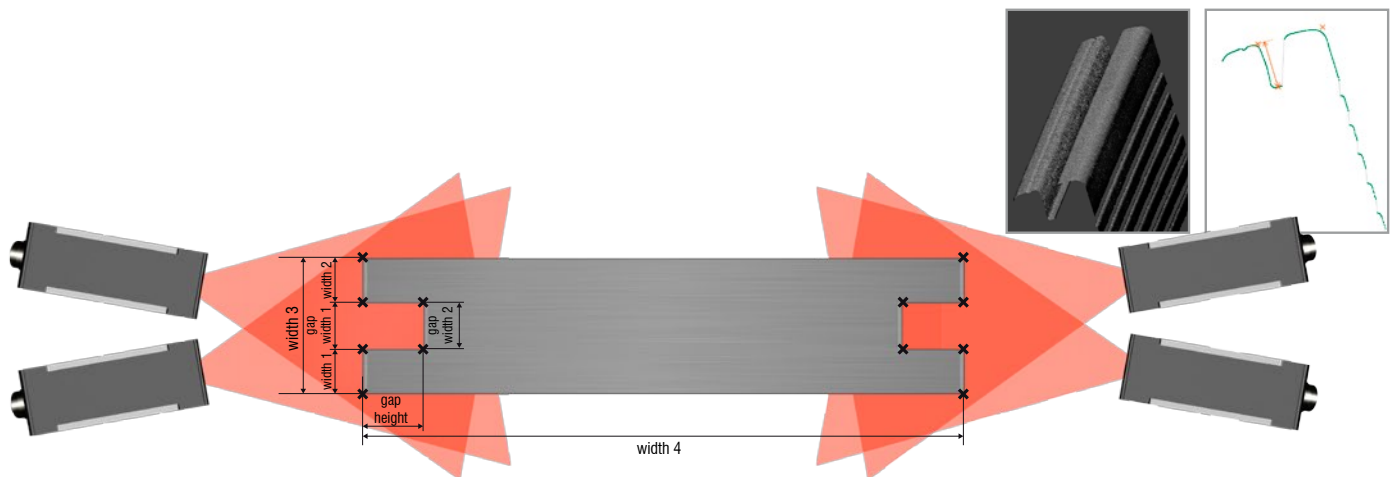

Profile control (profile width, land width, groove width, groove depth)

2D/3D Gateway

PROFINET / EtherCAT / EtherNet/IP for all SMART scanners

One 2D/3D Gateway is connectable with up to 4 sensors. Operation of more than one sensor requires a switch. The 2D/3D Gateway communicates with the scanCONTROL SMART sensor via Ethernet Modbus. The resultant values are then converted to PROFINET, EtherCAT or EtherNet/IP. The customer carries out the parameter setup with a detailed instruction manual. The gateway can also be parameterized in advance at the factory.

Models

6414142	2D/3D Gateway	Fieldbus coupler, configurable for PROFINET, EtherNet/IP and EtherCAT
6414142.001	2D/3D Gateway, pre-parameterized	Pre-parameterized to customer log and IP addresses
6411168	scanCONTROL SPU Switch, 5 ports	Industrial Ethernet Switch (unmanaged) for DIN rail, 10/100/1000 Mbit/s, 5 ports
6411167	scanCONTROL SPU Switch, 8 ports	Industrial Ethernet Switch (unmanaged) for DIN rail, 10/100/1000 Mbit/s, 8 ports

Number of sensors on the gateway	Maximum measurement frequency
1	500 Hz
2	500 Hz
3	330 Hz
4	250 Hz

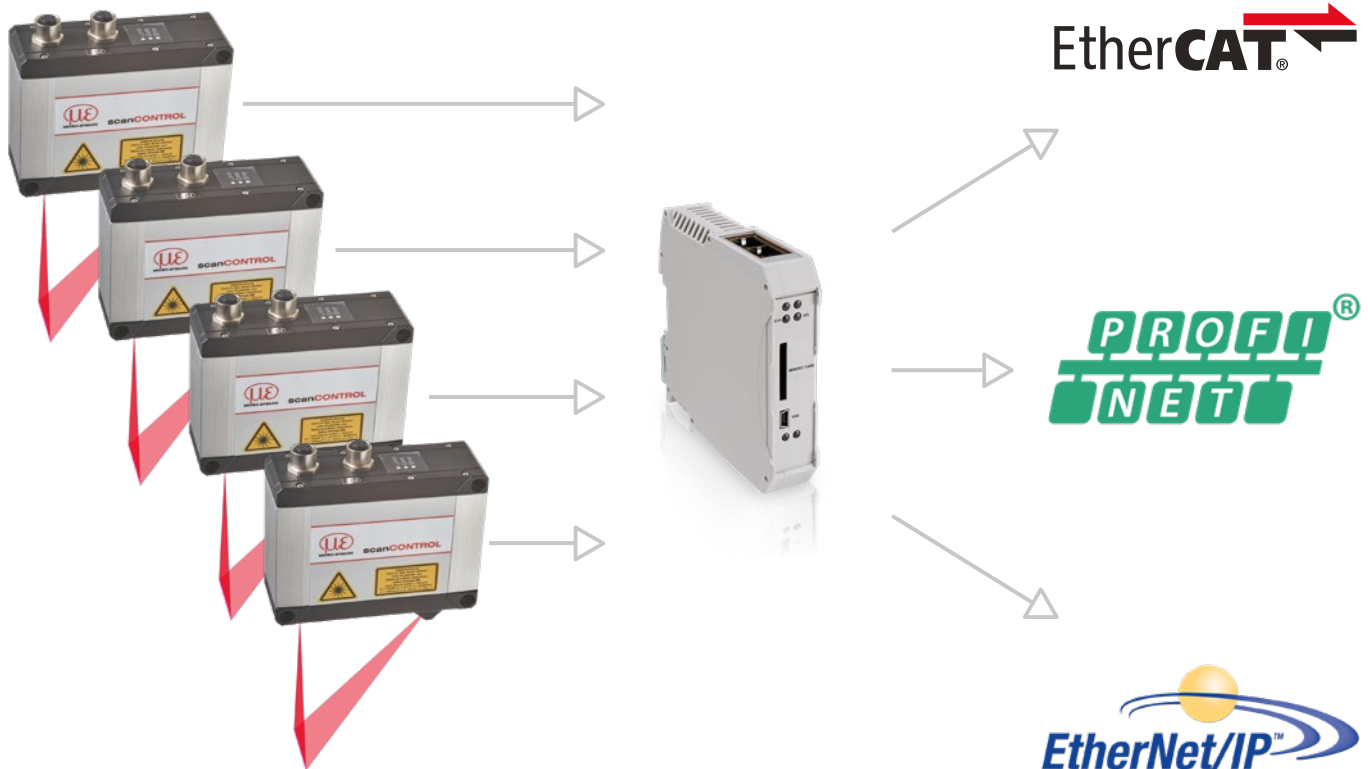

2D/3D Output Unit

Analog signals / digital switch signals for all **SMART** scanners

The 2D/3D Output Unit is addressed via Ethernet and outputs analog and digital signals. Different output terminals can be connected to the fieldbus coupler.

Models

6414073	2D/3D Output Unit Basic/ET	Fieldbus coupler with filter module and bus end terminal
0325131	OU-DigitalOut/8-channel/DC24V/0.5A/negative	8-channel digital output terminal; DC 24 V; 0.5 A; negative switching
0325115	OU-DigitalOut/8-channel/DC24V/0.5A/positive	8-channel digital output terminal; DC 24 V; 0.5 A; positive switching
0325116	OU-AnalogOut/4-channel/ $\pm 10V$	4-channel analog output terminal; $\pm 10 V$
0325135	OU-AnalogOut/4-channel/0-10V	4-channel analog output terminal; 0-10V
0325132	OU-AnalogOut/4-channel/0-20mA	4-channel analog output terminal; 0-20 mA
0325133	OU-AnalogOut/4-channel/4-20mA	4-channel analog output terminal; 4-20 mA

Other terminals available on request.

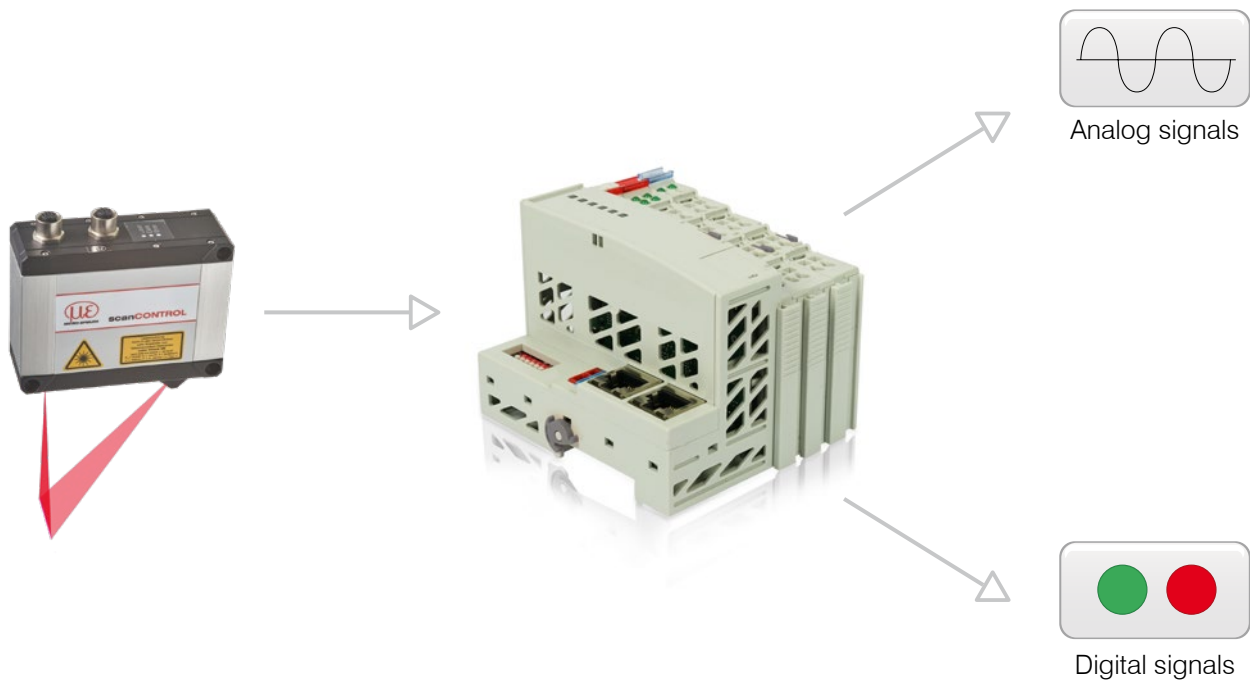

Protection and cooling housing for LLT25x0 and 29xx

(Not available for scanCONTROL 29xx-10/BL)

Protective housing with blow-out system

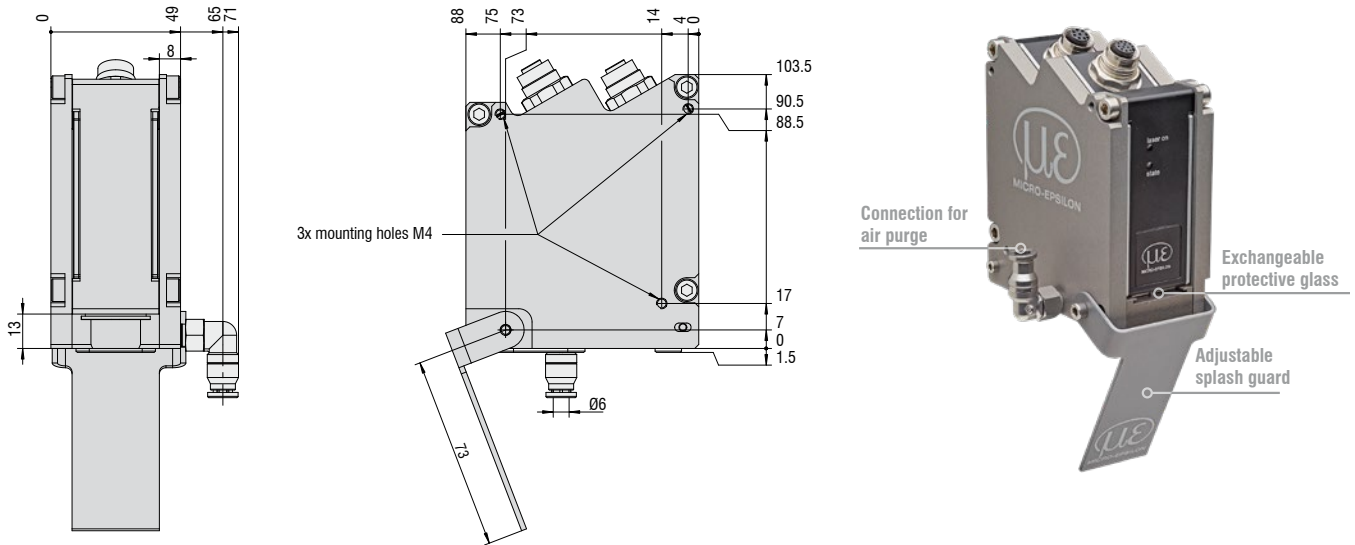

Protective housing with blow-out system and water cooling

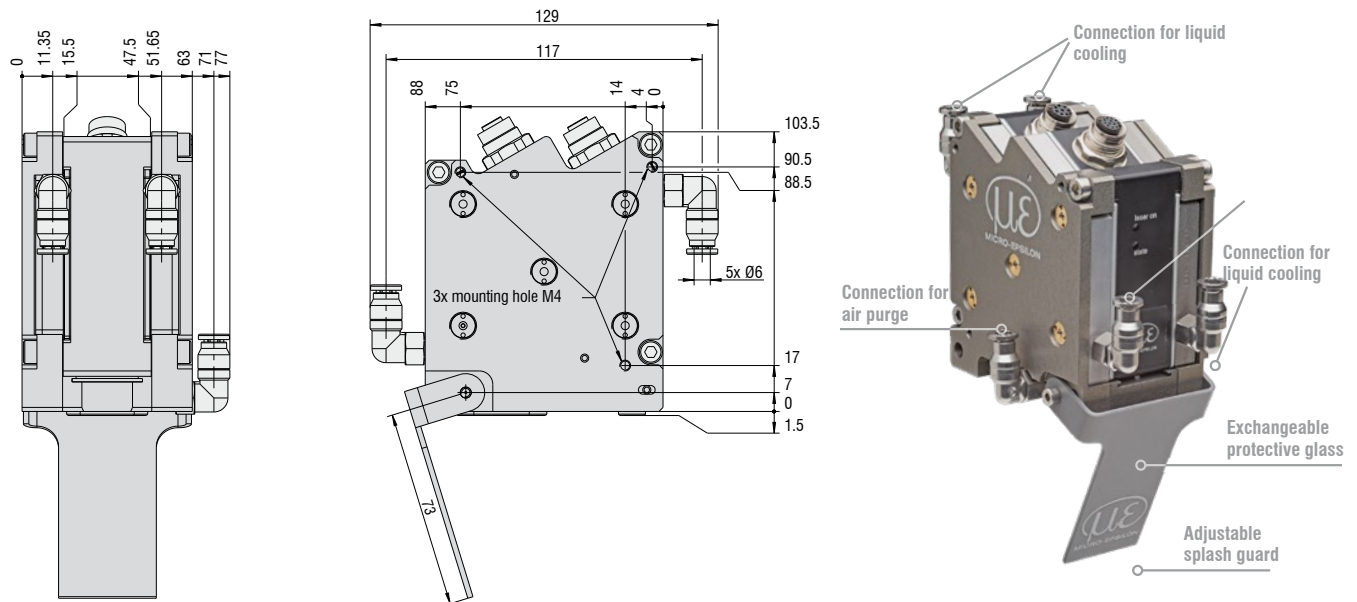

Art. no. Model

2105058	Protection housing for LLT25/29 series
2105059	Protective cooling housing for LLT25/29 series
0755075	Exchangeable glass for protective housing LLT25/29

Description

Adaptive protective housing for LLT25x0/29xx
Adaptive protection and cooling housing for LLT25x0/29xx
Exchangeable glass for protection/cooling concept LLT25/29, pack. with 50 pcs.

Protection and cooling housing for LLT30xx

Protective housing with blow-out system

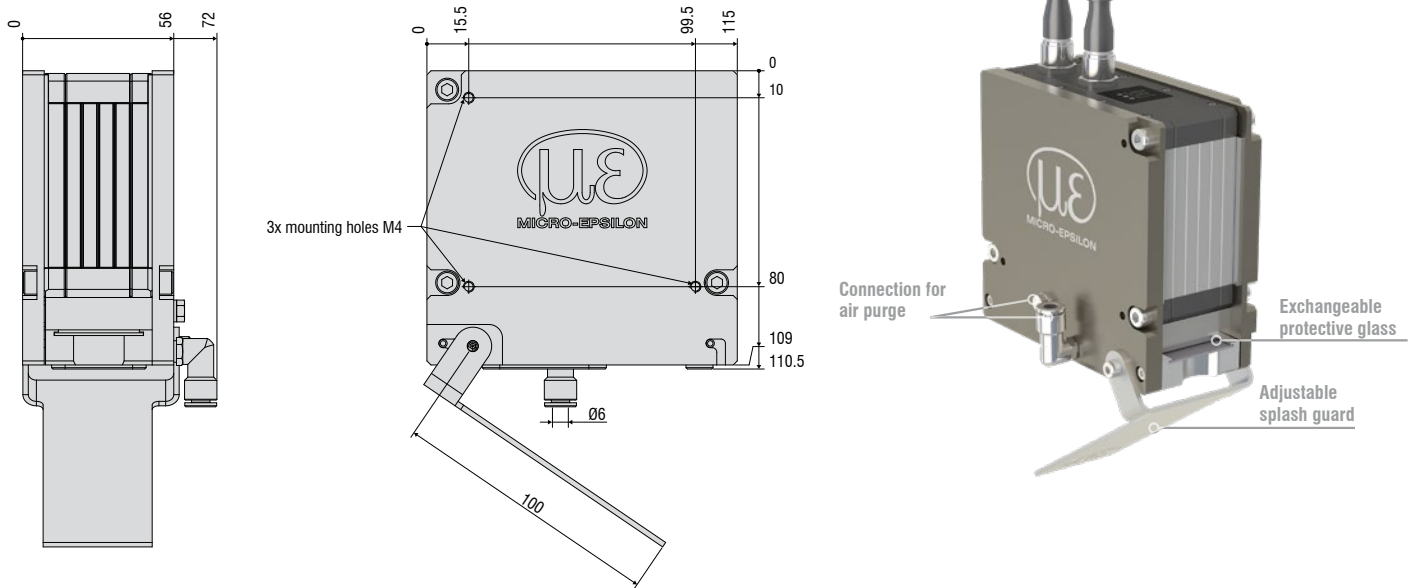

Protective housing with blow-out system and water cooling

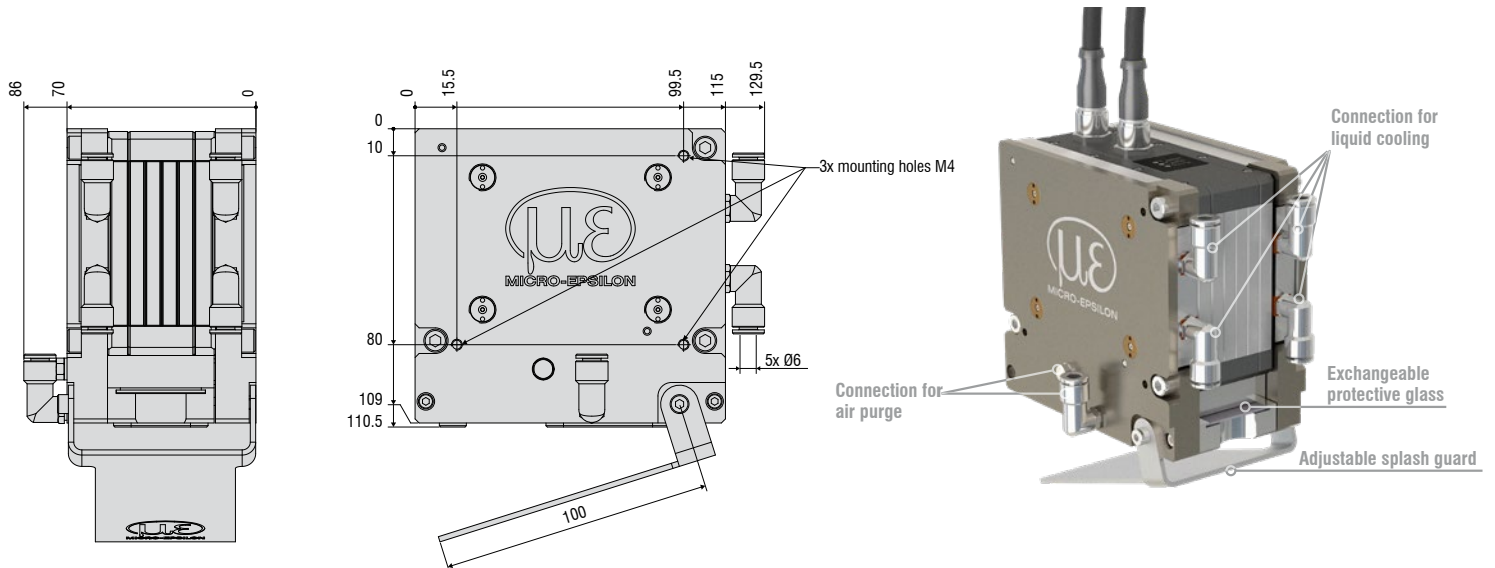

Art. no.	Model	Description
2105076	Protective housing for LLT30 series	Adaptive protective housing for LLT30xx
2105077	Protective cooling housing for LLT30 series	Adaptive protective and cooling housing for scanCONTROL 30xx
0755083	Exchangeable glass for protective housing LLT30	Exchangeable glass for protection/cooling concept LLT30, packaging unit 30 pcs.

Connection cables

PCR3000-x Multi-function cable

Cable for power supply, digital inputs;
suitable for drag chains and robots
(TTL or HTL), RS422 (half-duplex)
Cable length (m): 2 / 5 / 10 / 15 / 20 / 25 / 35



SCR3000A-x Ethernet connection cable

Cable for parameter setting, value and profile transmission;
suitable for drag chains and robots
Cable length (m): 0.5 / 2 / 5 / 10 / 15 / 20 / 25 / 35

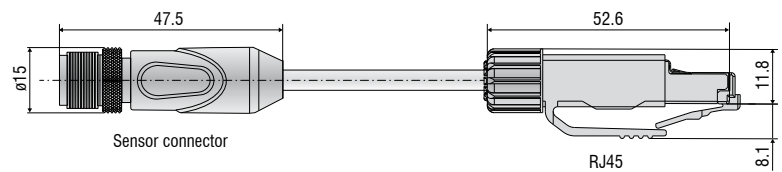

Other accessories

Art. no.	Model	Description
0323478	Connector/12-pin/Multifunction for LLT25/26/29/30 series	Plug for multifunction port
0323479	Connector/8-pin/Ethernet for LLT25/26/29/30 series	Plug for Ethernet socket
2420067	PS25/29/30	Power supply unit for scanCONTROL
0254111	Case for LLT25/26/29/30 series	Transport case for scanCONTROL sensors incl. measuring stand
2960097	Measuring stand for LLT25/26/29/30	Measuring stand with sensor adapter board, flexible rod and clamp base

surfaceCONTROL 3D 3500

Innovative 3D snapshot sensor for inline inspection of geometry, shapes and surfaces

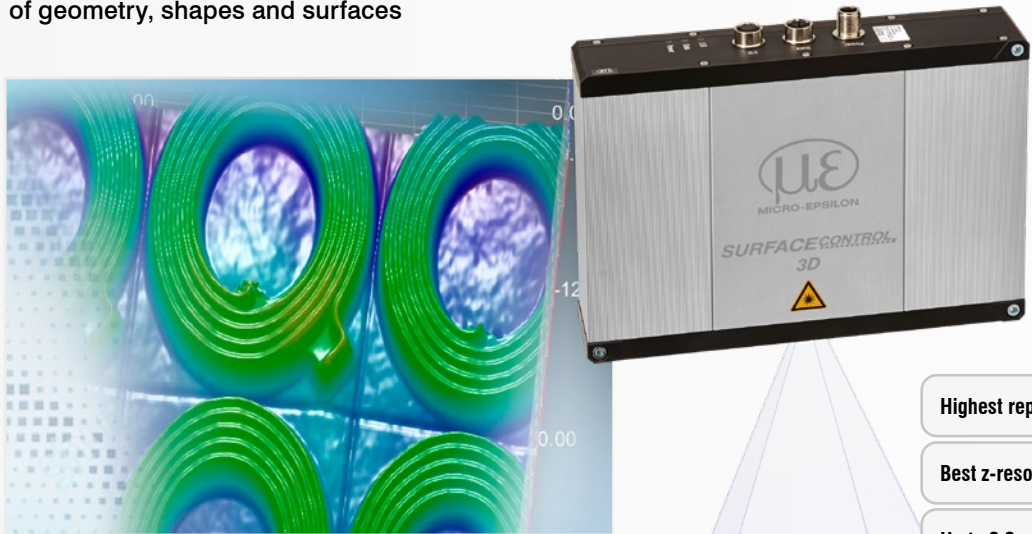

The image shows the SurfaceCONTROL 3D 3500 sensor unit, a rectangular device with a silver front panel and black top and bottom. The front panel features the Micro-Epsilon logo and the product name. To the left, a 3D scan of a ring-shaped part is shown with a color-coded height map. Below the sensor, a diagram illustrates the sensor's field of view and the resulting 3D point cloud scan of a flat surface.

- Highest repeatability up to $0.4 \mu\text{m}$
- Best z-resolution from $1.0 \mu\text{m}$
- Up to 2.2 million 3D points / second
- Easy integration in all common 3D image processing packets

reflectCONTROL

3D inline inspection of shiny surfaces: flat glass, mirrors and wafers

- Complete inspection of reflecting and shiny surfaces
- Highest z-accuracy $< 1 \mu\text{m}$
- Fastest 3D inspection $< 1 \text{ s}$
- High compatibility via different interfaces

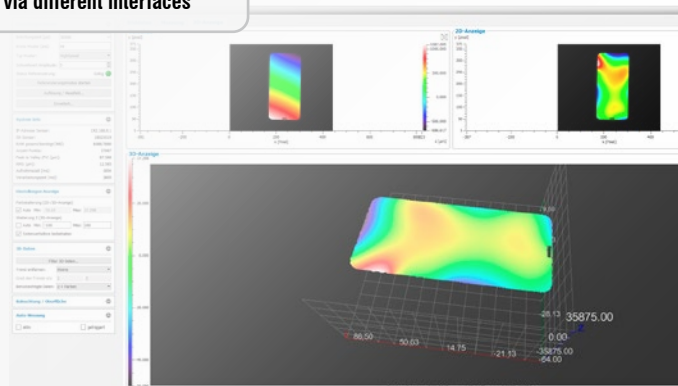
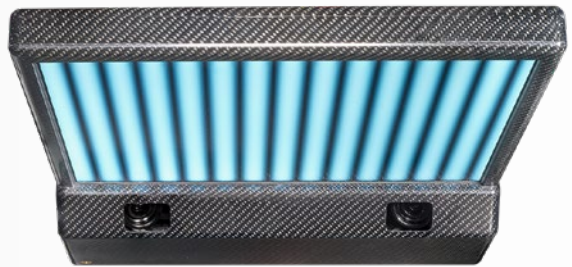

Sensors and Systems from Micro-Epsilon

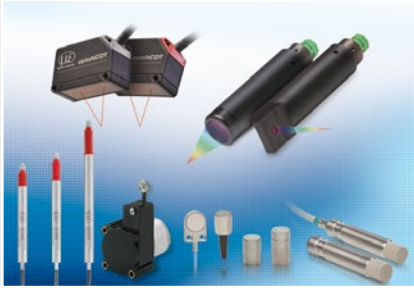

Sensors and systems for displacement, position and dimension



Sensors and measurement devices for non-contact temperature measurement



Measuring and inspection systems for quality assurance

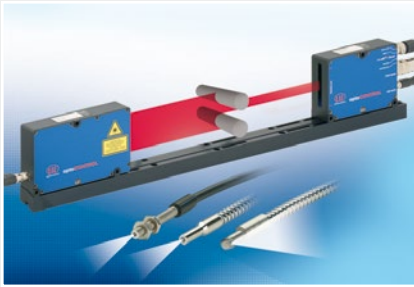

Optical micrometers, fiber optics, measuring and test amplifiers



Color recognition sensors, LED Analyzers and inline color spectrometers



3D measurement technology for dimensional testing and surface inspection

