



SCIGATE AUTOMATION (S) PTE LTD

No.1 Bukit Batok Street 22 #01-01 Singapore 659592

Tel: (65) 6561 0488

Fax: (65) 6562 0588

Email: sales@scigate.com.sg

Web: www.scigate.com.sg

Business Hours: Monday - Friday 8.30am - 6.15pm

More Precision

optoNCDT // Laser displacement sensors (triangulation)



Laser triangulation sensors optoNCDT

optoNCDT - Highest precision in laser displacement measurements

optoNCDT laser sensors set milestones for industrial laser displacement measurement. They stand out due to their size, measuring rate, functionality and, in particular, to their high precision. The current optoNCDT range comprises numerous sensor models, each of which is among the best in its class impressing in automation, inline quality assurance and machine building.

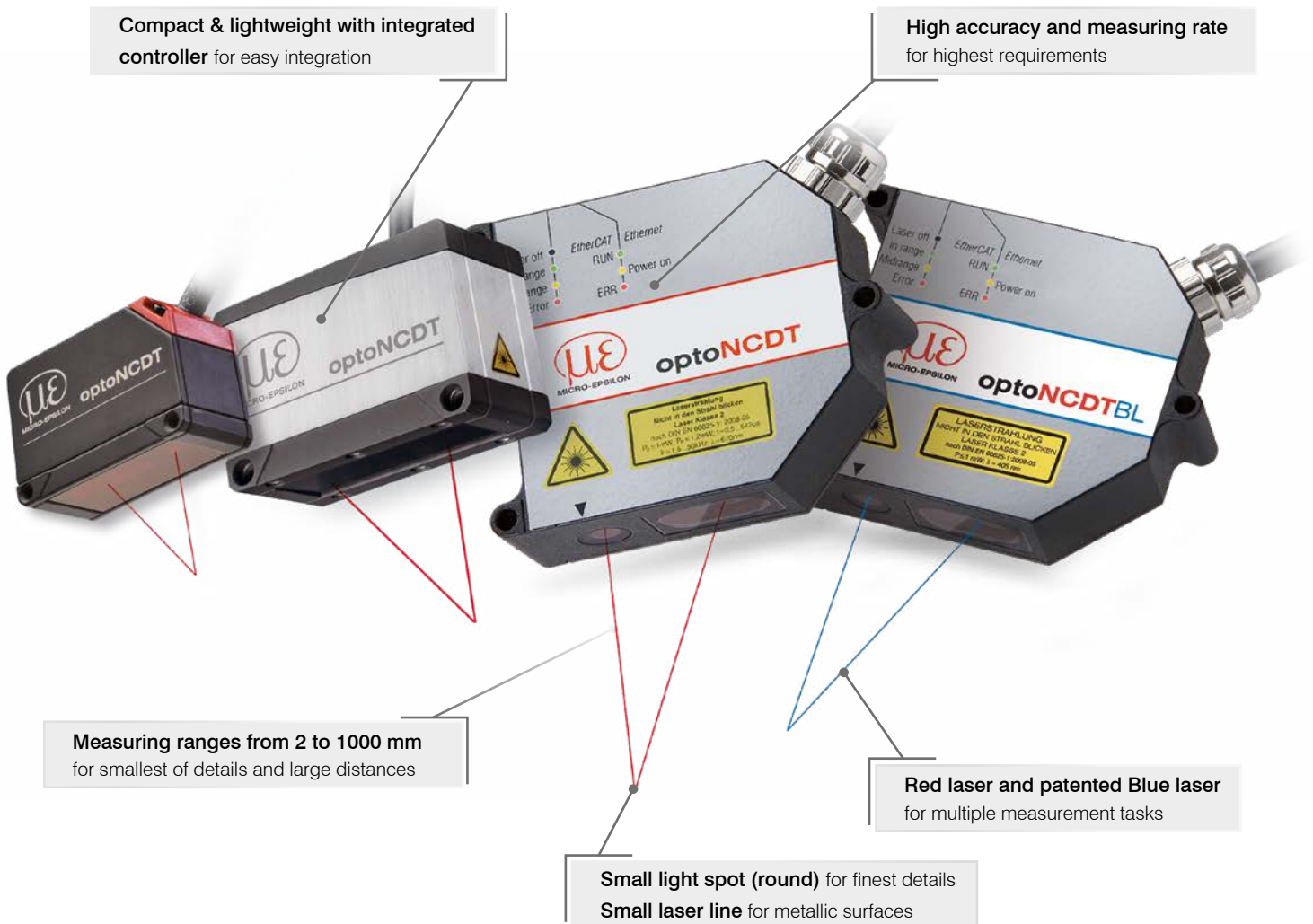

Reliable on all measuring objects & surfaces

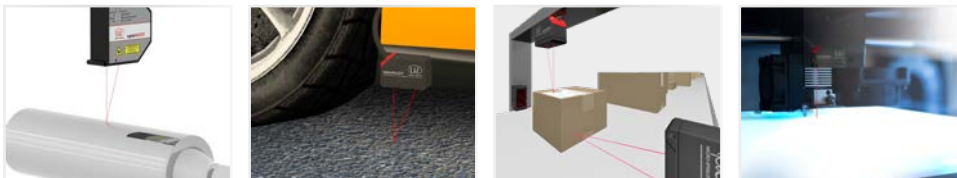

General information

4 - 5	Technology
6 - 7	Special features
8 - 9	Application examples

	Compact sensors	<i>Measuring range</i>	<i>Resolution / Repeatability</i>	<i>Linearity</i>	<i>Measuring rate</i>	<i>Type of reflection</i>	<i>Measuring object</i>
10 - 11	optoNCDT 1220	10 - 50 mm	1 μm *	0.10 %	up to 1 kHz	diffuse	all usual targets
12 - 13	optoNCDT 1320	10 - 100 mm	1 μm *	0.10 %	up to 2 kHz	diffuse	all usual targets
14 - 15	optoNCDT 1420	10 - 500 mm	0.5 μm *	from 0.08 %	up to 4 kHz	diffuse	all usual targets

Sensors for precision automation

16 - 17	optoNCDT 1900	2 - 500 mm	0.1 μm *	from 0.02 %	up to 10 kHz	diffuse	all usual targets
---------	----------------------	------------	---------------------	-------------	--------------	---------	-------------------

High performance sensors

18 - 19	optoNCDT 2300	2 - 300 mm	0.03 μm	from 0.02 %	up to 49.14 kHz	diffuse / direct	all usual targets
---------	----------------------	------------	--------------------	-------------	-----------------	------------------	-------------------

Sensors with small laser line for metal surfaces

20 - 21	optoNCDT 1420LL	10 - 50 mm	0.5 μm *	from 0.08 %	up to 4 kHz	diffuse	Metals
22 - 23	optoNCDT 1900LL	2 - 50 mm	0.1 μm *	from 0.02 %	up to 10 kHz	diffuse	Metals
24 - 25	optoNCDT 2300LL	2 - 50 mm	0.03 μm	from 0.02 %	up to 49.14 kHz	diffuse	Metals

Blue Laser sensors

26 - 27	optoNCDT 1710BL	50 / 1000 mm	7.5 μm	from 0.10 %	up to 2.5 kHz	diffuse	red-hot glowing / organic transparent
28 - 29	optoNCDT 1750BL	20 - 750 mm	0.8 μm *	from 0.06 %	up to 7.5 kHz	diffuse	
30 - 31	optoNCDT 2300BL	2 - 50 mm	0.03 μm	from 0.02 %	up to 49.14 kHz	diffuse / direct	

Laser sensors for reflective measuring objects

32 - 33	optoNCDT 1750-DR	2 - 20 mm	0.1 μm *	0.08 %	up to 7.5 kHz	direct	reflective
34 - 35	optoNCDT 2300-2DR	2 mm	0.03 μm	0.03 %	up to 49.14 kHz	direct	reflective

Long-range sensors with large offset distance and measuring range

36 - 37	optoNCDT 1710	50/1000 mm	from 7.5 μm	0.10 %	up to 2.5 kHz	diffuse	all usual targets
38 - 39	optoNCDT 1750	500/750 mm	20 μm *	from 0.07 %	up to 7.5 kHz	diffuse	all usual targets
40 - 41	optoNCDT 2310	10 - 50 mm	0.5 μm	0.03 %	up to 49.14 kHz	diffuse	all usual targets

Accessories

42 - 47	Cables, protective housings and interface modules
---------	--

*corresponds to repeatability

Laser sensors for industry & automation

optoNCDT

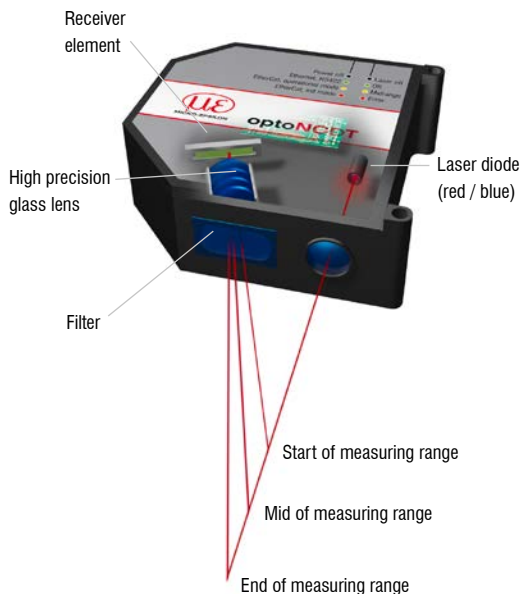

optoNCDT – Precise measurements for industry & automation

The optoNCDT sensors are designed for measurement tasks in factory automation, machines and systems. Despite their very compact dimensions, these robust laser sensors have a fully integrated controller. As a result, simple installation and wiring is possible in confined spaces or on a robot. Their high performance enables the sensors to provide precise measurement results at a high measuring rate.

Measuring principle of laser triangulation

Laser triangulation sensors operate with a laser diode that projects a visible light spot onto the surface of the target. The light reflected from the spot is imaged by an optical receiving system onto a position-sensitive element. If the light spot changes its position, this change is imaged on the receiving element and evaluated.

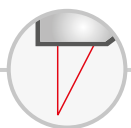

Numerous measuring ranges for versatile measurement tasks

optoNCDT laser triangulation sensors measure from a large distance to the target using a very small light spot. The large measurement distance enables non-contact measurements to be taken against difficult surfaces such as hot metals. More than 85 standard models with measuring ranges from 2 – 1000 mm cater for a large number of applications across many different industries.

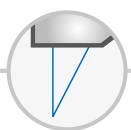
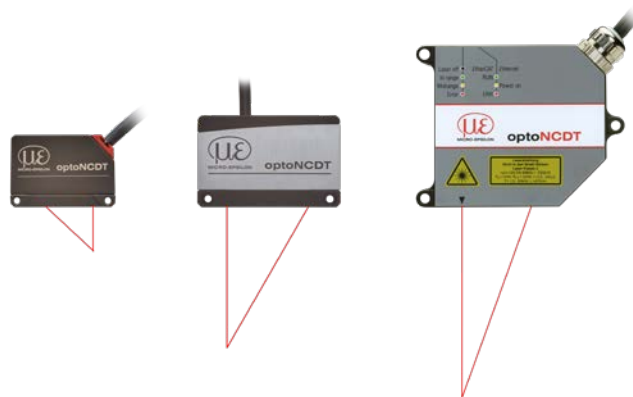

Innovative Blue Laser Sensors

The optoNCDT Blue Laser (BL) models use a blue-violet laser beam which does not penetrate the measuring object due to its shorter wavelength. The light spot is projected sharply to enable stable and precise measurement results. The Blue Laser Technology is preferably used with red-hot glowing metals as well as organic and transparent objects.



Patented Blue Laser Technology

Measurement tasks involving Blue Laser sensors on red-hot glowing objects exceeding 700 °C and transparent objects such as plastics, adhesives and glass are patented by Micro-Epsilon. On these surfaces, the optoNCDT Blue Laser models achieve excellent signal stability and high precision measurement results.

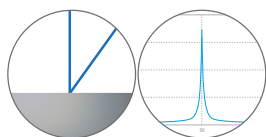
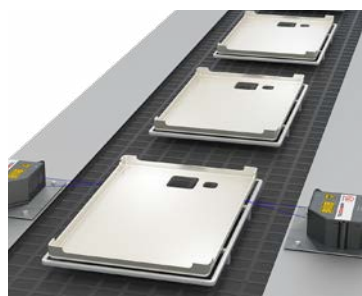

Position inspection of plastic parts: Blue laser light does not penetrate the material and is sharply projected onto the sensor element.

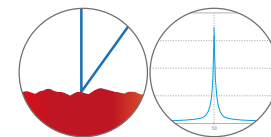

Positioning a welding head in automated welding units: no influence by red radiation

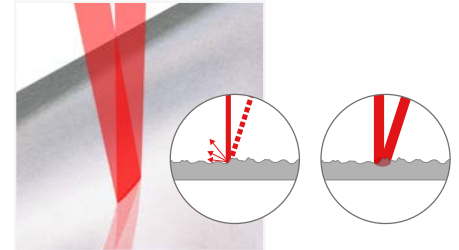
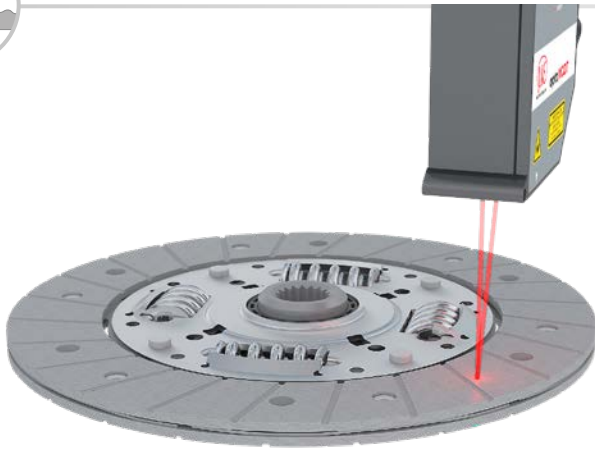

Laser-line sensors for reliable measurements on metallic surfaces

The optoNCDT LL sensors operate with a small laser line. The laser line and special software algorithms compensate for disturbances caused by surface roughness, defects, indentations or minute holes on metallic surfaces. This is how optoNCDT LL sensors achieve the highest precision with measurement tasks involving metals.

Rough and structured surfaces cause interferences within the laser point (left) which leads to a faulty projection on the sensor element. This effect becomes particularly obvious with metallic surfaces. The small laser line of the optoNCDT LL sensors compensates for this effect (right) and enables stable measurements on metallic surfaces.

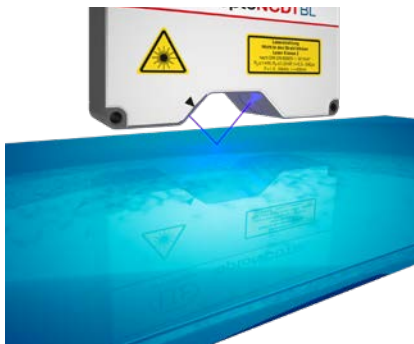
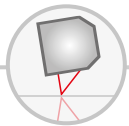

optoNCDT 2300-2DR sensors use direct reflection. They are designed for distance measurements of glass with anti-reflective coating.



Direct-reflection sensors for precise distance measurements on reflective surfaces

Conventional laser triangulation sensors are designed for diffuse reflecting surfaces. Specular surfaces such as shiny plastics, mirror glass or polished metals require a sensor alignment where the angle of incidence is equal to the angle of reflection. Micro-Epsilon offers sensors with special alignment (DR) for directly reflecting surfaces which ensure high accuracy and signal stability.



Long-range sensors for measurements from a safe distance

Some measurement tasks require a large measuring range or a large distance from the object to be measured. Long-range sensors from Micro-Epsilon combine large measuring ranges and large offset distances. They enable high accuracy measurements from a safe distance.

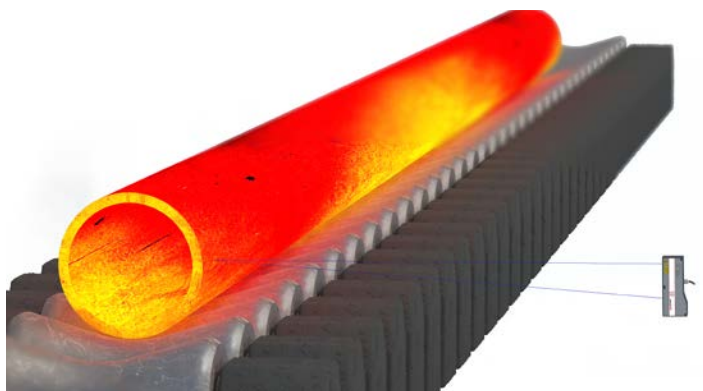

Versatile & precise optoNCDT

Unique ease of use via web interface

The optoNCDT sensors are operated using an intuitive web interface. Therefore, the sensor is connected to a PC and the web interface is called up in a browser. This convenient web interface enables the user to make numerous settings for the processing of measured values and signals, e.g., peak selection, filter and masking features for the video signal.

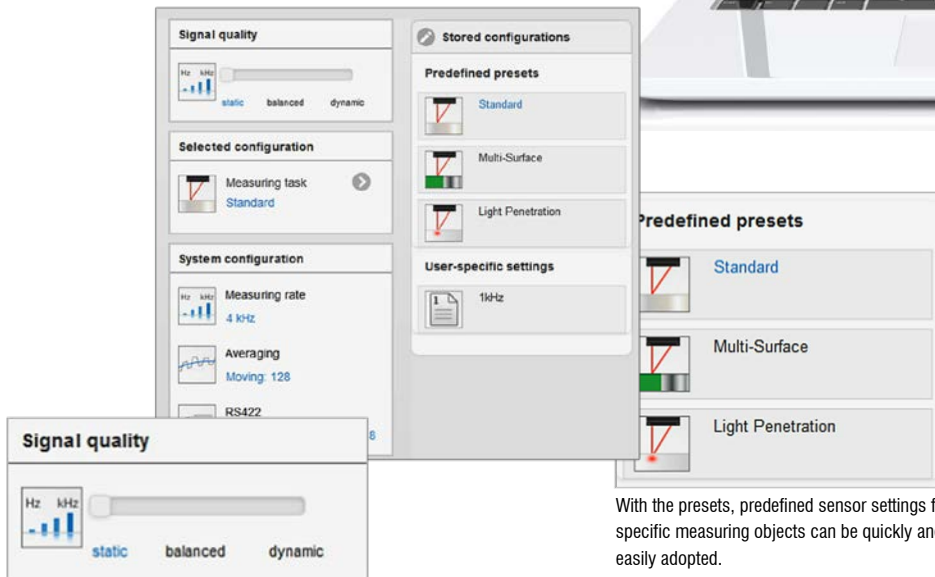

e.g., metal, ceramics,...

e.g., circuit boards, PCB,...

e.g., milk glass, plastics,...

With the presets, predefined sensor settings for specific measuring objects can be quickly and easily adopted.

The quality slider enables the user to define the signal evaluation regarding process and measurement dynamics. Depending on the selected settings, the measuring rate and the averaging of the sensor are adapted.

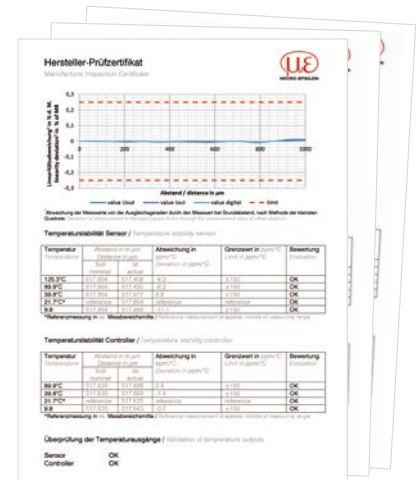
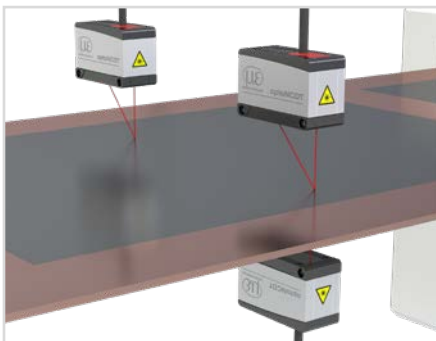

Certified quality with calibration protocol

To document the performance capability of the optoNCDT sensors, each sensor is calibrated before delivery and supplied with its own calibration protocol. This document is supplied with the sensor and proves the achieved measurement precision.

Synchronizable sensors for multi-track and thickness measurements

Operating several laser sensors to measure a track or the thickness requires synchronization. Synchronizing the sensors enables simultaneous measurement acquisition and ensures that the measurement values of the sensors are recorded at the same time. Due to their synchronization feature, optoNCDT sensors are suited to multi-track and thickness measurements in different industries.

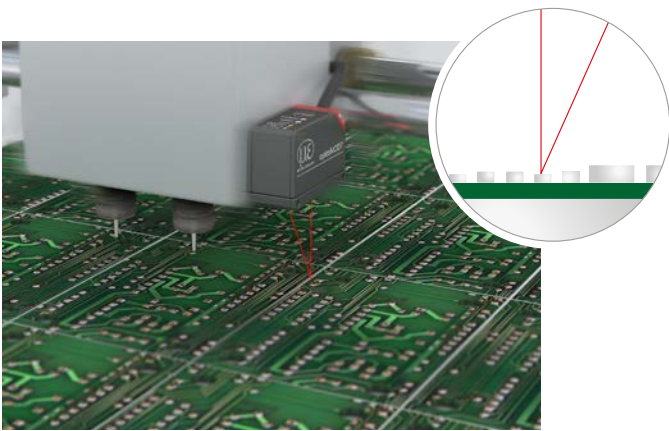

Fast dispenser positioning in PCB manufacture

Ultra-small light spot detects smallest details

Focusing the laser beam via a special lens arrangement in the sensor generates a small light spot on the target surface. This small light spot is required for a high spatial resolution and ensures that even the smallest of objects and details can be detected. The smaller the measuring range, the smaller the light spot. With laser sensors from Micro-Epsilon, the smallest measurement spot is $8.5 \times 11 \mu\text{m}$.

Ideal for fast control & positioning

When measuring poorly reflective surfaces or fast moving objects, high measuring rates are required. Sensors of the 2300 series achieve a measuring rate up to 49 kHz with concurrent real time surface compensation.

With their robust and compact design, these sensors are also suitable for measurements in traversing systems and robots.

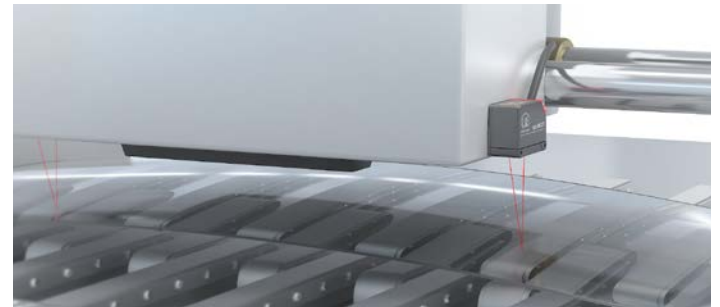

Print head positioning and focal point control in industrial printers



Fast position monitoring at the assembly robot

High precision with changing surfaces

optoNCDT sensors are equipped with intelligent control features which ensure high signal stability with bright/dark transition, regardless of the color and the brightness of the measuring object. This optimally adjusts the exposure time or the amount of light for the exposure cycle just performed or the next exposure cycle. These controls enable smooth signal courses without outliers even in dynamic measurements.

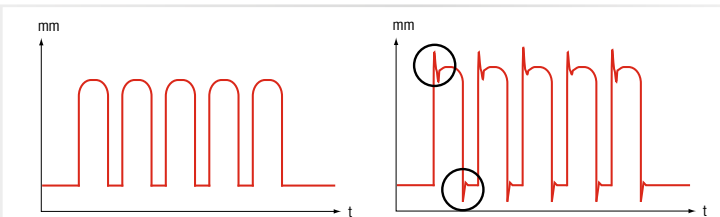

Comparison: optoNCDT sensor surface compensation (left) and conventional sensor providing faulty measurements with changing reflections (right)



The Active Surface Compensation provides stable distance signal control regardless of target color or brightness.



The Advanced Surface Compensation feature operates with new algorithms and enables stable measurement results even on demanding surfaces.



The real time surface compensation feature compensates for changing reflectance properties in the current measurement cycle. Each individual laser pulse is controlled in real time depending on the surface properties of the measuring object.



The Advanced Real Time Surface Compensation with its improved dynamic range enables a more precise real time surface compensation. This ensures maximum compensation of fluctuating reflectivity while generating stable measurement values with high accuracy.



optoNCDT Laser sensors - Application examples

Print head positioning and focal point control

In printing processes, the exact height of the print head is a crucial factor for the quality of the final product. High-speed distance measurement against different material surfaces and reliable edge detection enable fast readjustments to be made to the process.

Sensor: *optoNCDT 1420*

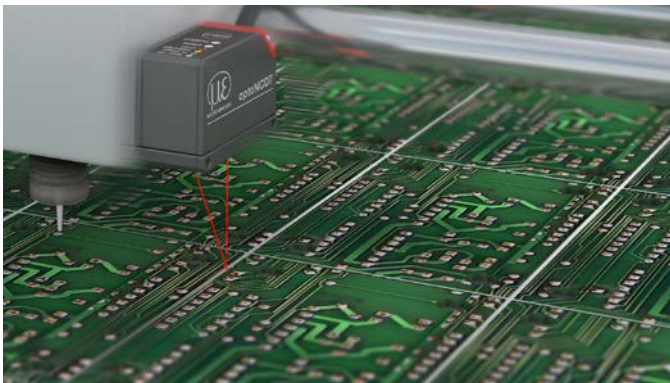

High-resolution fine positioning when printing PCBs

In printing, soldering and assembly processes of printed circuit boards, the exact height positioning of the print head is crucial for a flawless process. optoNCDT laser sensors enable precise positioning of the print head. Regardless of surface reflections, these sensors provide precise measurement results which are used to adjust the height and to detect the edges.

Sensor: *optoNCDT 1420*

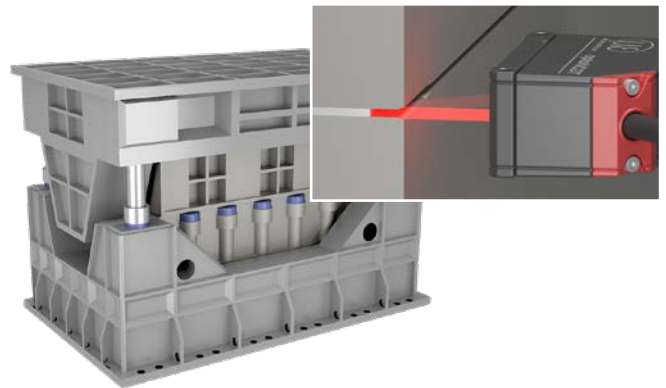

Monitoring the metal sheet infeed during pressing

During forming in the pressing plant, presence detection as well as the detection of the exact sheet position are required. Therefore, laser triangulation sensors measure on the sheet between the dies. The challenge here is to provide high measurement accuracy in confined installation spaces despite oil mist, vibrations and shocks. Since the measuring gap is very small, the diameter of the laser must be correspondingly small.

Sensor: *optoNCDT 1420*

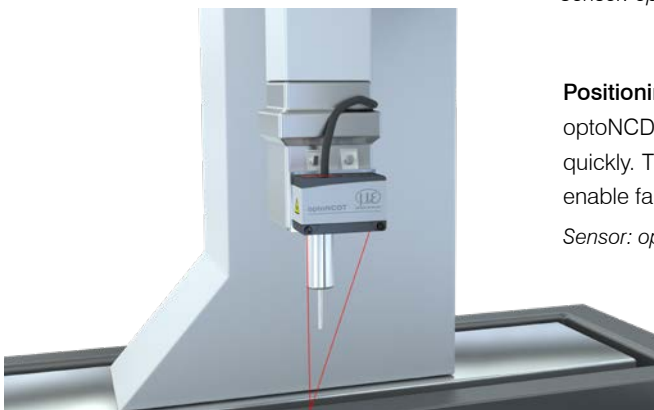

Positioning gauge heads in measuring machines

optoNCDT laser triangulation sensors are used to position sensor heads quickly. Thanks to their advanced sensor technology, the laser sensors enable fast and accurate positioning of the sensor head.

Sensor: *optoNCDT*

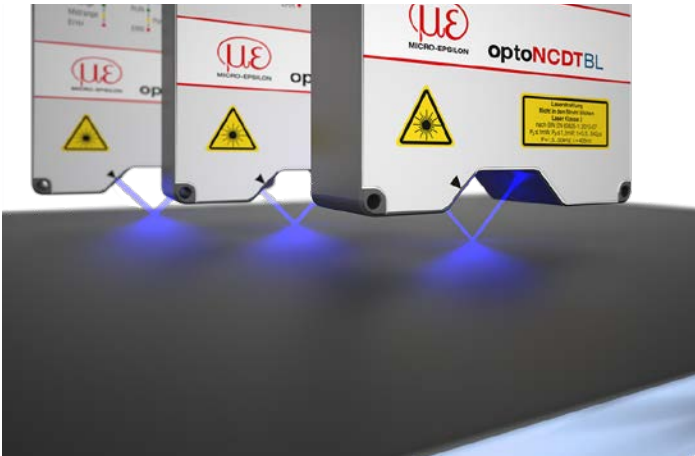

Distance measurement onto glass with anti-reflection coating

Anti-reflective coated glass is inspected during the coating process using laser-optical displacement sensors from Micro-Epsilon in order to determine undulations and torsion. The planarity of the coated glass surface is measured in several tracks. Based on the patented Blue Laser Technology, optoNCDT 2300-2DR sensors provide high measurement accuracies on coated glass surfaces.

Sensor: *optoNCDT 2300-2DR*



Measuring the wear of high-speed railway lines

For the inspection of high-speed railway lines, special measurement wagons are used. They are equipped with optoNCDT 1900LL laser displacement sensors, which detect the distance to the track at a high measuring rate. Their small laser line compensates for irregularities in order to generate smoothed measurement value curves. This is particularly suitable for determining the longitudinal trend. These robust sensors are hardly affected by fluctuating reflections and ambient light.

Sensor: *optoNCDT 1900LL*

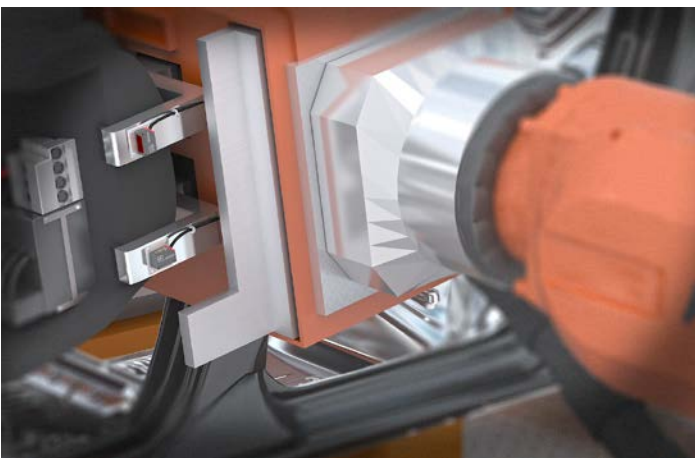

Position detection of the car body

For automated processing of car bodies, an exact determination of the position relative to the processing tool is necessary (drilling, punching, fitting, subassemblies). For high precision distance measurement onto metallic surfaces, laser triangulation sensors are used.

Sensor: *optoNCDT 1420*

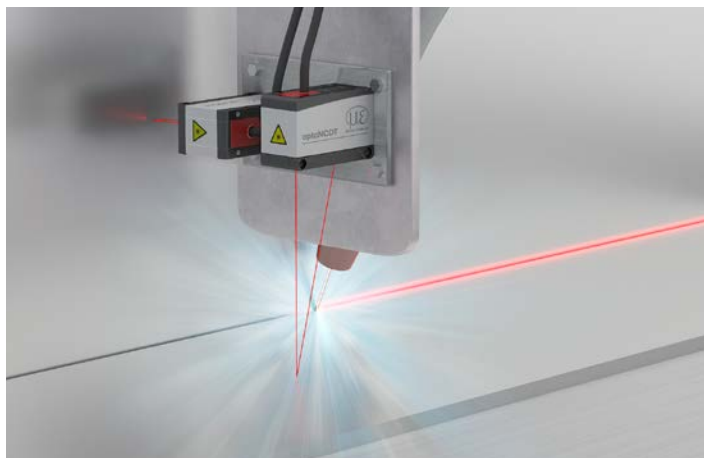







Distance control with fully automatic laser welding

In fully automatic welding units, welding head positioning is crucial for the quality of the welded joint. In order to position the welding head at the correct distance, optoNCDT 1900 laser sensors are used. These measure the distance from the steel plates with high accuracy and dynamics. As they offer the highest insensitivity to ambient light in their class, the laser sensors are ideal for the distance control of welding heads.

Sensor: *optoNCDT 1900*



Compact laser sensors for series applications optoNCDT 1220

-  For common surfaces
-  Measuring rate up to 1 kHz
-  Analog output (I)
-  Active Surface Compensation
-  Repeatability 1 μm
-  Ideal for series and OEM applications
-  Low weight, ideal for high accelerations



The optoNCDT 1220 is a new, compact laser triangulation sensor with precise displacement, distance and position measurements. This laser sensor is available with measuring ranges from 10 to 50 mm and offers both high measurement accuracy and an adjustable measuring rate up to 1 kHz.

Due to its extremely compact size with integrated controller, the sensor can also be installed in restricted spaces. Its low weight makes this laser sensor ideally suited to applications where high accelerations occur, e.g., on the robot gripper or in industrial printers.

The Active Surface Compensation (ASC) provides stable distance signal regardless of target color or brightness. Commissioning is quick and easy via function keys or the web interface.

The optoNCDT 1220 offers a unique combination of design, versatility and measurement accuracy. Due to its excellent price/performance ratio, the sensor is ideal for automation tasks and OEM integration with a large number of pieces.

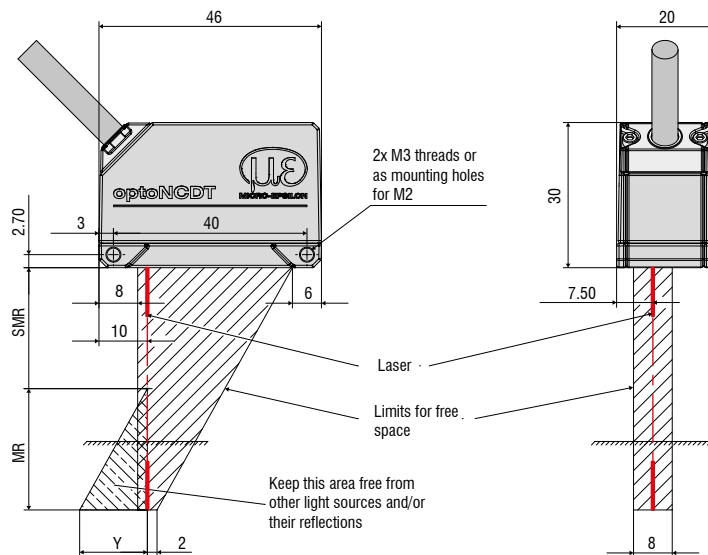

MR	SMR	Y
10	20	10
25	25	21
50	35	28

Model		ILD1220-10	ILD1220-25	ILD1220-50
Measuring range		10 mm	25 mm	50 mm
Start of measuring range		20 mm	25 mm	35 mm
Mid of measuring range		25 mm	37.5 mm	60 mm
End of measuring range		30 mm	50 mm	85 mm
Measuring rate ¹⁾		3 adjustable stages: 1 kHz / 0.5 kHz / 0.25 kHz		
Linearity		< ±10 μm	< ±25 μm	< ±50 μm
		< ±0.10 % FSO		
Repeatability ²⁾		3.7 μm	9.2 μm	18.4 μm
Temperature stability		±0.015 % FSO / K		
Light spot diameter (±10 %)	SMR	90 x 120 μm	100 x 140 μm	90 x 120 μm
	MMR	45 x 40 μm	120 x 130 μm	230 x 240 μm
	EMR	140 x 160 μm	390 x 500 μm	630 x 820 μm
	smallest diameter	45 x 40 μm with 24 mm	55 x 50 μm with 31 mm	70 x 65 μm with 42 mm
Light source		Semiconductor laser < 1 mW, 670 nm (red)		
Laser safety class		Class 2 in accordance with DIN EN 60825-1: 2015-07		
Permissible ambient light ³⁾		20,000 lx		
Supply voltage		11 ... 30 VDC		
Power consumption		< 2 W (24 V)		
Signal input		1 x HTL laser on/off; 1 x HTL multifunction input: trigger in / zero setting / teach		
Analog output		4 ... 20 mA (12 bit, freely scalable within the measuring range) ⁴⁾		
Switching output		1 x error output: npn, pnp, push pull		
Connection		integrated cable 2 m, open ends, minimum bending radius 30 mm (fixed installation)		
Installation		Screw connection via two mounting holes		
Temperature range	Storage	-20 ... +70 °C (non-condensing)		
	Operation	0 ... +50 °C (non-condensing)		
Shock (DIN EN 60068-2-27)		15 g / 6 ms in 3 axes, 1000 shocks each		
Vibration (DIN EN 60068-2-6)		20 g / 20 ... 500 Hz in 3 axes, 2 directions and 10 cycles each		
Protection class (DIN EN 60529)		IP65		
Material		Aluminum housing		
Weight		approx. 30 g (without cable), approx. 110 g (incl. cable)		
Control and display elements		Select button: zero / teach / factory settings; web interface for setup ⁵⁾ ; 2 x color LEDs for power / status		

FSO = Full Scale Output

SMR = Start of measuring range, MMR = Mid of measuring range, EMR = End of measuring range

The specified data apply to white, diffuse reflecting surfaces (Micro-Epsilon reference ceramic for ILD sensors)

¹⁾ Factory setting 1 kHz, modifying the factory setting requires the IF2001/USB converter (see accessories)

²⁾ Measuring rate 1 kHz, median 9

³⁾ Illuminant: light bulb







⁴⁾ The D/A conversion is executed at 12 bits

⁵⁾ Connection to PC via IF2001/USB (see accessories)



Compact laser sensors for industry & automation

optoNCDT 1320

-  For common surfaces
-  Measuring rate up to 2 kHz
-  **INTERFACE** Analog (I) / RS422
-  **ASC** Active Surface Compensation
-  Repeatability 1 μm
-  Ideal for series and OEM applications
-  Low weight, ideal for high accelerations



The optoNCDT 1320 is a very compact laser triangulation sensor intended for entry-level precision measurement tasks. This series is used to measure displacement, distance and position. The controller is integrated in the housing which considerably simplifies the installation procedure. Since the sensor is extremely compact, it can also be integrated into restricted installation spaces. Due to its low weight, the optoNCDT 1320 is ideally suited to applications with high accelerations, e.g., on the robot arm or in pick-and-place machines.

The optoNCDT 1320 offers high measurement accuracy and adjustable measuring rates up to 2 kHz. The Active Surface Compensation (ASC) provides stable distance signal control regardless of target color or brightness.

Very small objects can be detected reliably due to the small and sharply projected measurement spot size.

Unique ease of use

The optoNCDT 1320 models enable quick sensor commissioning using the multifunction sensor button. If required, further sensor settings can be made via the web interface. With the "Standard", "Changing surfaces" and "Material with penetration" settings included in the web interface, precise measurement results are easily achieved without any complex optimization. The quality slider enables the sensor to be adapted to static and dynamic processes.

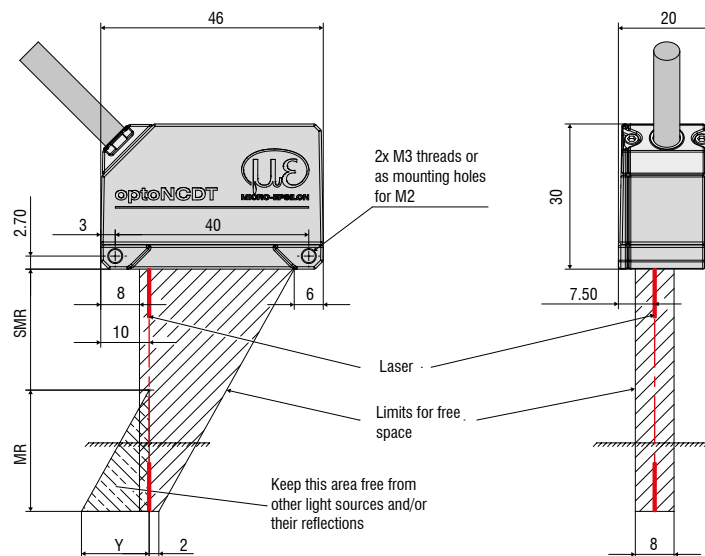

(dimensions in mm, not to scale)

MR	SMR	Y
10	20	10
25	25	21
50	35	28
100	50	46

Model		ILD1320-10	ILD1320-25	ILD1320-50	ILD1320-100
Measuring range		10 mm	25 mm	50 mm	100 mm
Start of measuring range		20 mm	25 mm	35 mm	50 mm
Mid of measuring range		25 mm	37.5 mm	60 mm	100 mm
End of measuring range		30 mm	50 mm	85 mm	150 mm
Measuring rate ¹⁾		4 adjustable stages: 2 kHz / 1 kHz / 0.5 kHz / 0.25 kHz			
Linearity		< ±10 μm	< ±25 μm	< ±50 μm	< ±100 μm
		< ±0.10 % FSO			
Repeatability ²⁾		1 μm	2.5 μm	5 μm	10 μm
Temperature stability		±0.015 % FSO / K			±0.01 % FSO / K
Light spot diameter (±10 %)	SMR	90 x 120 μm	100 x 140 μm	90 x 120 μm	750 x 1100 μm
	MMR	45 x 40 μm	120 x 130 μm	230 x 240 μm	
	EMR	140 x 160 μm	390 x 500 μm	630 x 820 μm	
	smallest diameter	45 x 40 μm with 24 mm	55 x 50 μm with 31 mm	70 x 65 μm with 42 mm	-
Light source		Semiconductor laser < 1 mW, 670 nm (red)			
Laser safety class		Class 2 in accordance with DIN EN 60825-1: 2015-07			
Permissible ambient light ³⁾		30,000 lx			20,000 lx
Supply voltage		11 ... 30 VDC			
Power consumption		< 2 W (24 V)			
Signal input		1 x HTL laser on/off; 1 x HTL multifunction input: trigger in / zero setting / mastering / teach			
Digital interface		RS422 (16 bit) / PROFINET ⁴⁾ / EtherNet/IP ⁴⁾			
Analog output		4 ... 20 mA (12 bit, freely scalable within the measuring range) ⁵⁾			
Switching output		1 x error output: npn, pnp, push pull			
Connection		integrated cable 3 m, open ends, minimum bending radius 30 mm (fixed installation)			
Mounting		Screw connection via two mounting holes			
Temperature range	Storage	-20 ... +70 °C (non-condensing)			
	Operation	0 ... +50 °C (non-condensing)			
Shock (DIN EN 60068-2-27)		15 g / 6 ms in 3 axes, 1000 shocks each			
Vibration (DIN EN 60068-2-6)		20 g / 20 ... 500 Hz in 3 axes, 2 directions and 10 cycles each			
Protection class (DIN EN 60529)		IP65			
Material		Aluminum housing			
Weight		approx. 30 g (without cable), approx. 145 g (incl. cable)			
Control and display elements		Select button: zero, teach, factory setting; Web interface for setup with defined presets ⁶⁾ ; 2 x color LEDs for power / status			

FSO = Full Scale Output

SMR = Start of measuring range, MMR = Mid of measuring range, EMR = End of measuring range

The specified data apply to white, diffuse reflecting surfaces (Micro-Epsilon reference ceramic for ILD sensors)

¹⁾ Factory setting 1 kHz; modifying the factory setting requires the IF2001/USB converter (see accessories)

²⁾ Measuring rate 1 kHz, median 9

³⁾ Illuminant: light bulb

⁴⁾ Connection via interface module (see accessories)







⁵⁾ The D/A conversion is executed at 12 bits

⁶⁾ Connection to PC via IF2001/USB (optionally available)



Smart laser sensors for industry & automation

optoNCDT 1420

-  For common surfaces
-  Measuring rate up to 4 kHz
-  **INTERFACE** Analog (U/I) / RS422 / PROFINET / EtherNet/IP
-  **ASC** Active Surface Compensation
-  Repeatability 0.5 μm
-  Ideal for series and OEM applications
-  Low weight, ideal for high accelerations



The optoNCDT 1420 offers a unique combination of speed, size, performance and application versatility in the class of compact triangulation sensors. The sensor is equipped with an integrated controller and achieves high measurement accuracy at measuring rates of up to 4 kHz. The selectable connector type (cable or pigtail) minimizes the installation effort for the sensor. The Active Surface Compensation (ASC) provides stable distance signal control. The high-performance optical system projects a small light spot onto the target which enables the reliable detection of even the smallest of components and details. Analog and digital output signals enable the sensor to be integrated into plant and machine control systems.

Unique ease of use, individual results

All optoNCDT 1420 models are operated using an extended web interface. The settings for the measurement task can be quickly selected using predefined presets. The quality slider enables the sensor to be adapted to static and dynamic processes. Up to eight user-specific sensor settings can be stored and exported in the setup management. The video signal display, the signal peak selection and a freely adjustable signal averaging enable optimization of the measurement task. The ROI function (region of interest) allows, e.g., for interfering signals in the background to be filtered out. The remaining signal peak is optimally corrected.

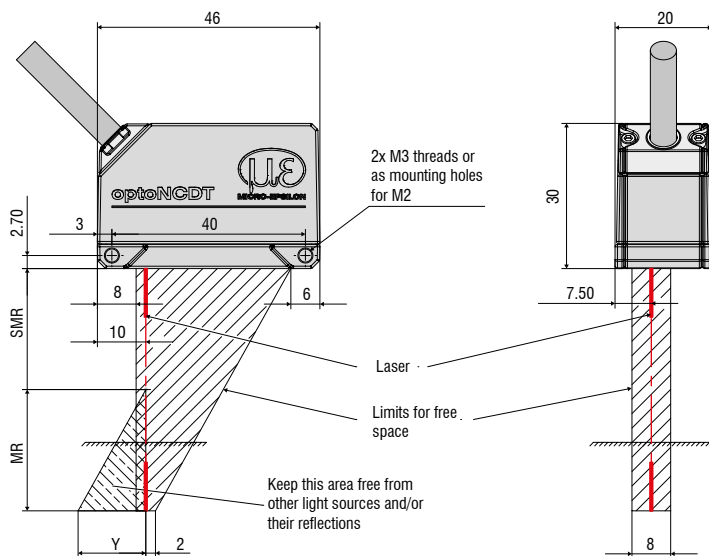

(dimensions in mm, not to scale)

Connector (sensor side)

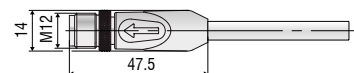

MR	SMR	Y
10	20	10
25	25	21
50	35	28
100	50	46
200	60	70
500	100	190

Model	ILD1420-10	ILD1420-25	ILD1420-50	ILD1420-100	ILD1420-200	ILD1420-500	
Measuring range	10 mm	25 mm	50 mm	100 mm	200 mm	500 mm	
Start of measuring range	20 mm	25 mm	35 mm	50 mm	60 mm	100 mm	
Mid of measuring range	25 mm	37.5 mm	60 mm	100 mm	160 mm	350 mm	
End of measuring range	30 mm	50 mm	85 mm	150 mm	260 mm	600 mm	
Measuring rate ¹⁾	5 adjustable stages: 4 kHz / 2 kHz / 1 kHz / 0.5 kHz / 0.25 kHz						
Linearity	< ±8 μm	< ±20 μm	< ±40 μm	< ±80 μm	< ±160 μm	< ±500 ... ±1000 μm	
	< ±0.08 % FSO					< ±0.1 ... ±0.2 % FSO	
Repeatability ²⁾	0.5 μm	1 μm	2 μm	4 μm	8 μm	20 ... 40 μm	
Temperature stability	±0.015 % FSO / K			±0.01 % FSO / K			
Light spot diameter (±10 %)	SMR	90 x 120 μm	100 x 140 μm	90 x 120 μm	750 x 1100 μm	750 x 1100 μm	750 x 1100 μm
	MMR	45 x 40 μm	120 x 130 μm	230 x 240 μm			
	EMR	140 x 160 μm	390 x 500 μm	630 x 820 μm			
	smallest diameter	45 x 40 μm with 24 mm	55 x 50 μm with 31 mm	70 x 65 μm with 42 mm	-	-	
Light source	Semiconductor laser < 1 mW, 670 nm (red)						
Laser safety class	Class 2 in accordance with DIN EN 60825-1: 2015-07 ³⁾						
Permissible ambient light ⁴⁾	50,000 lx			30,000 lx	10,000 lx		
Supply voltage	11 ... 30 VDC						
Power consumption	< 2 W (24 V)						
Signal input	1 x HTL laser on/off; 1 x HTL multifunction input: trigger in / zero setting / mastering / teach						
Digital interface	RS422 (16 bit) / PROFINET ⁵⁾ / EtherNet/IP ⁵⁾						
Analog output	4 ... 20 mA / 1 ... 5 V with PCF1420-3/U cable (12 bit, freely scalable within the measuring range) ⁶⁾						
Switching output	1 x error output: npn, pnp, push pull						
Connection	integrated cable 3 m, open ends, min. bending radius 30 mm (fixed installation) or integrated pigtail 0.3 m with 12-pin M12 plug (see accessories for suitable connection cable)						
Mounting	Screw connection via two mounting holes						
Temperature range	Storage	-20 ... +70 °C (non-condensing)					
	Operation	0 ... +50 °C (non-condensing)					
Shock (DIN EN 60068-2-27)	15 g / 6 ms in 3 axes, 1000 shocks each						
Vibration (DIN EN 60068-2-6)	20 g / 20 ... 500 Hz in 3 axes, 2 directions and 10 cycles each						
Protection class (DIN EN 60529)	IP65						
Material	Aluminum housing						
Weight	approx. 60 g (incl. pigtail), approx. 145 g (incl. cable)						
Control and display elements	Select button: zero, teach, factory setting; web interface for setup ⁷⁾ : selectable presets, peak selection, video signal, freely selectable averaging, data reduction, setup management; 2 x color LEDs for power / status						

FSO = Full Scale Output

SMR = Start of measuring range, MMR = Mid of measuring range, EMR = End of measuring range

The specified data apply to a white, diffuse reflecting surface (Micro-Epsilon reference ceramic for ILD sensors)

¹⁾ Factory setting 2 kHz, modifying the factory setting requires the IF2001/USB converter (see accessories)

²⁾ Measuring rate 2 kHz, median 9

³⁾ Also available on request with laser safety class 1 (≤ 0.39 mW)

⁴⁾ Illuminant: light bulb

⁵⁾ Connection via interface module (see accessories)









⁶⁾ D/A conversion is executed with 12 bit

⁷⁾ Connection to PC via IF2001/USB (see accessories)



Smart laser sensors for precise measurements

optoNCDT 1900

-  For common surfaces
-  Measuring rate up to 10 kHz
- INTER FACE**  Analog (U/I) / RS422 / PROFINET / EtherNet/IP
- ASc**  Advanced Surface Compensation
-  Repeatability <math>< 0.1 \mu\text{m}</math>
-  Ideal for series and OEM applications
-  Highest immunity to ambient light
-  High resistance to shocks and vibrations

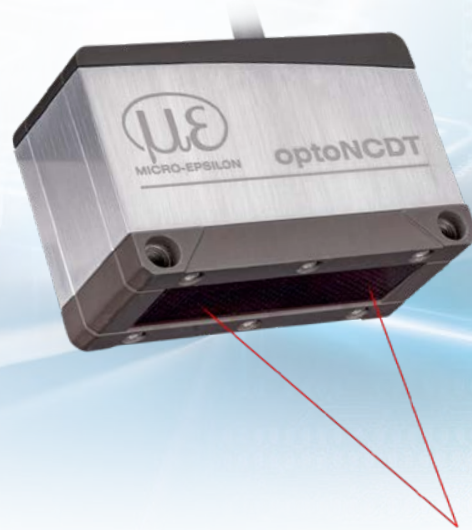

Next-generation laser sensors

This optoNCDT 1900 is used for dynamic displacement, distance and position measurements offering a unique combination of high speed, compact design and accuracy. The integrated high-performance controller enables fast and highly precise processing and output of measurement values. The innovative optoNCDT 1900 laser triangulation sensor is used whenever maximum precision is combined with the latest technology, e.g., in sophisticated automation, automotive production, 3D printing and coordinate measuring machines.

Simple installation and initial operation

Via a mounting with fitting sleeves, the sensor is automatically aligned in the correct position. This enables both easy sensor replacement and increased measurement accuracy.

Highest stability based on intelligent signal optimization

For the first time, a two-step measurement value averaging feature is available to optimize the signal. This enables a smooth signal at edges and steps. Especially for high speed measurements of moving parts, measurement averaging enables a precise signal course.

Advanced Surface Compensation –

The intelligent exposure control for demanding surfaces

The optoNCDT 1900 is equipped with an intelligent surface control feature. Innovative algorithms generate stable measurement results even on demanding surfaces where changing reflections occur. Furthermore, these new algorithms compensate for ambient light up to 50,000 lux. Therefore, this is the sensor with the highest resistance to ambient light in its class which can even be used in strongly illuminated environments.

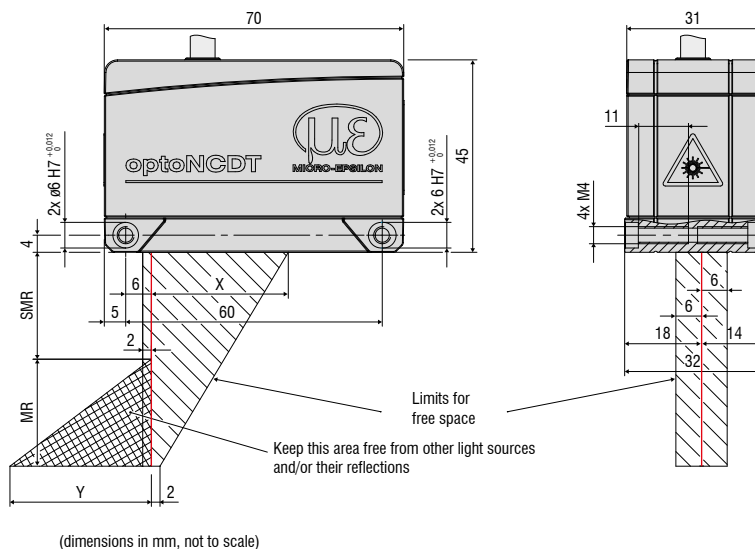

Connector (sensor side)

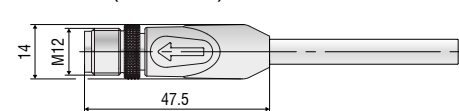

MR	SMR	X	Y
2	15	23	3
10	20	33	14
25	25	33	33
50	40	36	45
100	50	37	75
200	60	39	130
500	100	43	215

Model		ILD1900-2	ILD1900-10	ILD1900-25	ILD1900-50	ILD1900-100	ILD1900-200	ILD1900-500
Measuring range		2 mm	10 mm	25 mm	50 mm	100 mm	200 mm	500 mm
Start of measuring range		15 mm	20 mm	25 mm	40 mm	50 mm	60 mm	100 mm
Mid of measuring range		16 mm	25 mm	37.5 mm	65 mm	100 mm	160 mm	350 mm
End of measuring range		17 mm	30 mm	50 mm	90 mm	150 mm	260 mm	600 mm
Measuring rate ¹⁾		continuously adjustable between 0.25 ... 10 kHz						
		7 adjustable stages: 10 kHz / 8 kHz / 4 kHz / 2 kHz / 1.0 kHz / 500 Hz / 250 Hz						
Linearity ²⁾		< ±1 μm	< ±2 μm	< ±5 μm	< ±10 μm	< ±30 μm	< ±100 μm	< ±400 μm
		< ±0.05 % FSO	< ±0.02 % FSO			< ±0.03 % FSO	< ±0.05 % FSO	< ±0.08 % FSO
Repeatability ³⁾		< 0.1 μm	< 0.4 μm	< 0.8 μm	< 1.6 μm	< 4 μm	< 8 μm	< 20 ... 40 μm
Temperature stability ⁴⁾		±0.005 % FSO / K						
Light spot diameter (±10 %) ⁵⁾	SMR	60 x 75 μm	115 x 150 μm	200 x 265 μm	220 x 300 μm	310 x 460 μm	950 x 1200 μm	950 x 1200 μm
	MMR	55 x 65 μm	60 x 65 μm	70 x 75 μm	95 x 110 μm	140 x 170 μm		
	EMR	65 x 75 μm	120 x 140 μm	220 x 260 μm	260 x 300 μm	380 x 410 μm		
	smallest diameter	55 x 65 μm with 16 mm	60 x 65 μm with 25 mm	65 x 70 μm with 35 mm	85 x 90 μm with 55 mm	120 x 125 μm with 75 mm	-	-
Light source		Semiconductor laser < 1 mW, 670 nm (red)						
Laser safety class		Class 2 in accordance with DIN EN 60825-1: 2015-07						
Permissible ambient light		50,000 lx				30,000 lx	10,000 lx	
Supply voltage		11 ... 30 VDC						
Power consumption		< 3 W (24 V)						
Signal input		1 x HTL/TTL laser on/off; 1 x HTL/TTL multi-function input: trigger in, slave in, zero setting, mastering, teach-in; 1 x RS422 synchronization input: trigger in, sync in, master/slave, master/slave alternating						
Digital interface		RS422 (18 bit) / PROFINET ⁶⁾ / EtherNet/IP ⁶⁾						
Analog output		4 ... 20 mA / 0 ... 5 V / 0 ... 10 V (16 bit, freely scalable within the measuring range)						
Switching output		2x switching outputs (error & limit value): npn, pnp, push pull						
Synchronization		possible for simultaneous or alternating measurements						
Connection		integrated cable 3 m, open ends, min. bending radius 30 mm (fixed installation); or integrated pigtail 0.3 m with 17-pin M12 plug; optional extension to 3 m / 6 m / 9 m / 15 m possible (suitable connection cable see Accessories)						
Temperature range	Storage	-20 ... +70 °C (non-condensing)						
	Operation	0 ... +50 °C (non-condensing)						
Shock (DIN EN 60068-2-27)		15 g / 6 ms in 3 axes						
Vibration (DIN EN 60068-2-6)		30 g / 20 ... 500 Hz						
Protection class (DIN EN 60529)		IP67						
Material		Aluminum housing						
Weight		approx. 185 g (incl. pigtail), approx. 300 g (incl. cable)						
Control and display elements		Select & function keys: interface selections, mastering (zero), teach, presets, quality slider, frequency selection, factory settings; web interface for setup ⁷⁾ : application-specific presets, peak selection, video signal, freely selectable averaging possibilities, data reduction, setup management; 2 x color LEDs for power / status						

FSO = Full Scale Output

SMR = Start of measuring range, MMR = Mid of measuring range, EMR = End of measuring range

The specified data apply to a white, diffuse reflecting surface (Micro-Epsilon reference ceramic for ILD sensors)

¹⁾ Factory setting: measuring rate 4 kHz, median 9; modifying the factory setting requires the IF2001/USB converter (see accessories)

²⁾ Relates to digital output

³⁾ Typical value with measurements at 4 kHz and median 9

⁴⁾ Relates to digital output in mid of measuring range







⁵⁾ Light spot diameter determined using a point-shaped laser with Gaussian fit (full 1/e² width); for ILD1900-2: determined with emulated 90/10 knife-edge method

⁶⁾ Connection via interface module (see accessories)

⁷⁾ Connection to PC via IF2001/USB (see accessories)



Highly dynamic laser sensors with high precision optoNCDT 2300

-  For common surfaces
-  Adjustable measuring rate up to 49.14 kHz
- INTERFACE**  Analog (U/I) / RS422 / Ethernet / EtherCAT / PROFINET / EtherNet/IP
- A-RTSC**  Advanced Real Time Surface Compensation
-  Resolution 0.03 μm
-  For diffuse and reflective surfaces



The optoNCDT 2300 is the high-end model of Micro-Epsilon laser triangulation sensors with an adjustable measuring rate of up to 49.14 kHz. The entire electronics is integrated in a compact sensor housing which is a worldwide unique feature of this sensor class. The high precision laser sensor is particularly suitable for high speed applications such as the monitoring of vibrations or measurements on challenging surfaces. It is used on diffuse reflective surfaces and for directly reflecting surfaces when equipped with the special alignment feature.

The new A-RTSC (Advanced Real Time Surface Compensation) feature is a development based on the proven RTSC technology and, with its improved dynamic range, enables more precise real time surface compensation during the measurement process. The optoNCDT 2300 laser sensors can be operated via a web interface which offers multiple possibilities in order to process measured values and signals, e.g., peak selection, filter and masking of the video signal.

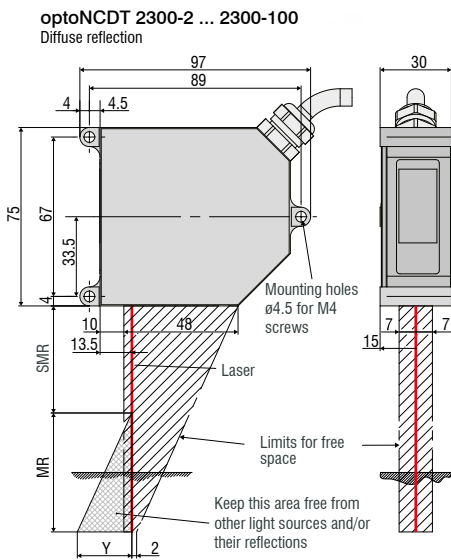

(dimensions in mm, not to scale)

MR	SMR	Y
2	24	1.5
5	24	3.5
10	30	6.5
20	40	10.0
50	45	23.0
100	70	33.5

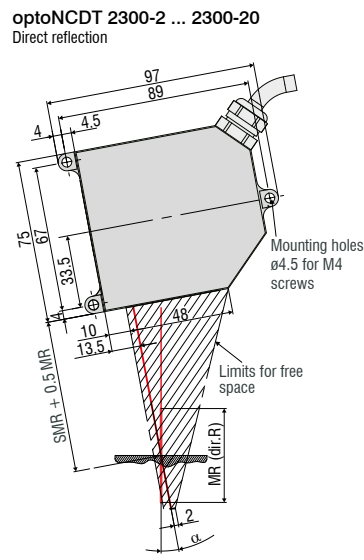

Connector (sensor side)

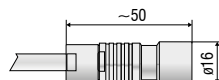

MR	SMR + 0.5 MR	α
2	25	20.5°
5	26.5	20°
10	35	17.5°
20	50	13.8°

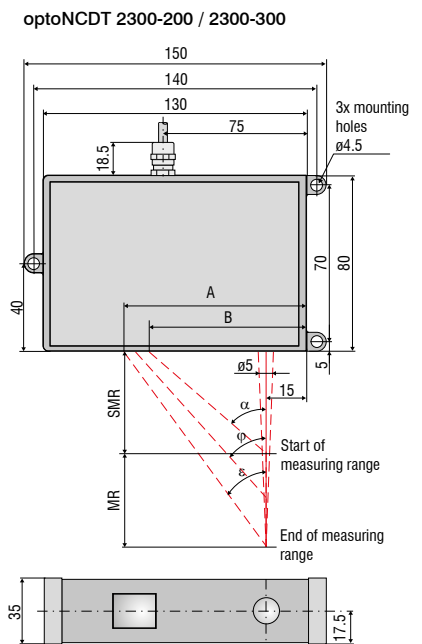

MR	α	φ	ϵ	A	B
200	25.1°	16.7°	13.1°	91.6	76
300	18.3°	12.2°	9.6°	99.4	81

Model	ILD2300-2	ILD2300-5	ILD2300-10	ILD2300-20	ILD2300-50	ILD2300-100	ILD2300-200	ILD2300-300	
Measuring range ¹⁾	2 (2) mm	5 (2) mm	10 (5) mm	20 (10) mm	50 (25) mm	100 (50) mm	200 (100) mm	300 (150) mm	
Start of measuring range ¹⁾	24 (24) mm	24 (24) mm	30 (35) mm	40 (50) mm	45 (70) mm	70 (120) mm	130 (230) mm	200 (350) mm	
Mid of measuring range ¹⁾	25 (25) mm	26.5 (25) mm	35 (37.5) mm	50 (55) mm	70 (82.5) mm	120 (145) mm	230 (280) mm	350 (425) mm	
End of measuring range ¹⁾	26 (26) mm	29 (26) mm	40 (40) mm	60 (60) mm	95 (95) mm	170 (170) mm	330 (330) mm	500 (500) mm	
Measuring rate	7 adjustable stages: 49.14 kHz ²⁾ / 30 kHz / 20 kHz / 10 kHz / 5 kHz / 2.5 kHz / 1.5 kHz								
Linearity	< ±0.6 μm	< ±1.5 μm	< ±2 μm	< ±4 μm	< ±10 μm	< ±20 μm	< ±60 μm	< ±90 μm	
	< ±0.03 % FSO			< ±0.02 % FSO			< ±0.03 % FSO		
Resolution ³⁾	0.03 μm	0.08 μm	0.15 μm	0.3 μm	0.8 μm	1.5 μm	3 μm	4.5 μm	
Light spot diameter (±10 %)	SMR	55 x 85 μm	70 x 80 μm	75 x 85 μm	140 x 200 μm	255 x 350 μm	350 μm	580 x 860 μm	
	MMR	23 x 23 μm	30 x 30 μm	32 x 45 μm	46 x 45 μm	70 x 70 μm	130 μm	380 x 380 μm	
	EMR	35 x 85 μm	70 x 80 μm	110 x 160 μm	140 x 200 μm	255 x 350 μm	350 μm	470 x 530 μm	
Light source	Semiconductor laser < 1 mW, 670 nm (red)								
Laser safety class	Class 2 in accordance with DIN EN 60825-1 : 2015-07 / optional class 3R								
Permissible ambient light	10,000...40,000 lx								
Supply voltage	11 ... 30 VDC								
Power consumption	< 3 W (24 V)								
Signal input	Laser on/off, sync in, trigger in								
Digital interface	RS422 (16 bit) / Ethernet / EtherCAT / PROFINET ⁴⁾ / EtherNet/IP ⁴⁾								
Analog output ⁴⁾	4 ... 20 mA / 0 ... 5 V / 0 ... 10 V / ±5 V / ±10 V								
Synchronization	possible for simultaneous or alternating measurements								
Connection	integrated pigtail 0.25 m with 14-pin cable connector, min. bending radius 30 mm (fixed installation); optional extension to 3 m / 6 m / 9 m possible (see accessories for suitable connection cable)								
Mounting	Screw connection via three mounting holes								
Temperature range	Storage	-20 ... +70 °C (non-condensing)							
	Operation	0 ... +50 °C (non-condensing)							
Shock (DIN EN 60068-2-27)	15 g / 6 ms in 3 axes								
Vibration (DIN EN 60068-2-6)	2 g / 20 ... 500 Hz								
Protection class (DIN EN 60529)	IP65								
Material	Die-cast zinc housing						Aluminum housing		
Weight	approx. 550 g (incl. pigtail)								
Control and display elements	Web interface for setup: user management, measurement settings, data output, measurement control, parameters, extras; 2 x color LEDs for Status / Ethernet and EtherCAT								

FSO = Full Scale Output

SMR = Start of measuring range, MMR = Mid of measuring range, EMR = End of measuring range

The specified data apply to white, diffuse reflecting surfaces (Micro-Epsilon reference ceramic for ILD sensors)

¹⁾ Value in brackets is valid for a measuring rate of 49.14 kHz

²⁾ Measuring rate of 49.14 kHz with reduced measuring range (in brackets)





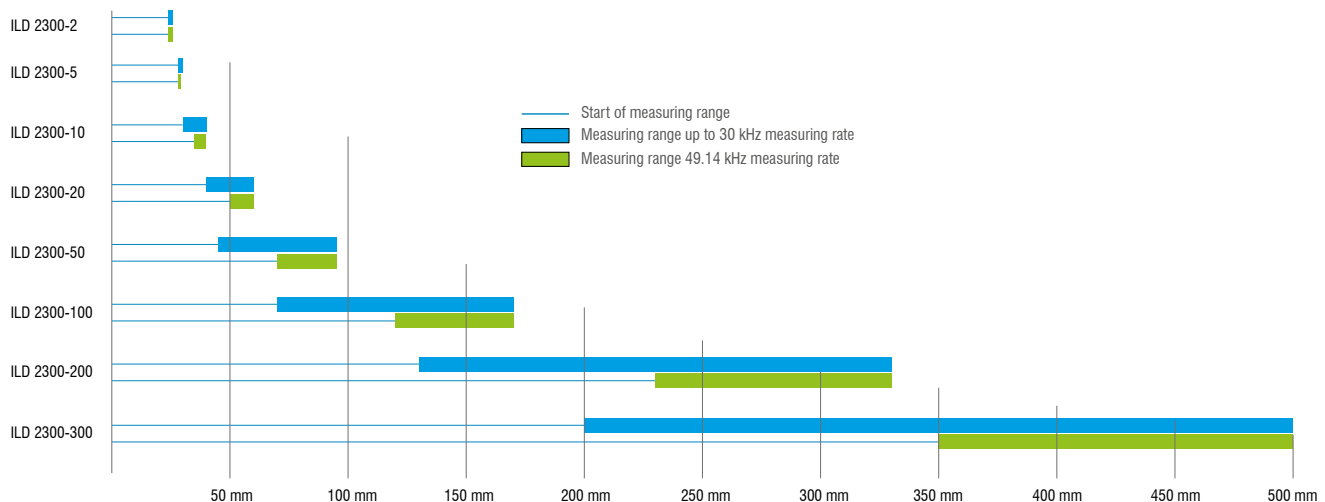

³⁾ Measuring rate of 20 kHz

⁴⁾ Connection via interface module (see accessories)





Compact laser sensors with small laser line optoNCDT 1420LL

- 
For shiny metallic, rough and structured surfaces
- 
Measuring rate up to 4 kHz
- 
ANALOG (U/I) / RS422 / PROFINET / EtherNet/IP
- 
ASC Active Surface Compensation
- 
Repeatability 0.5 μ m
- 
Low weight, ideal for high accelerations

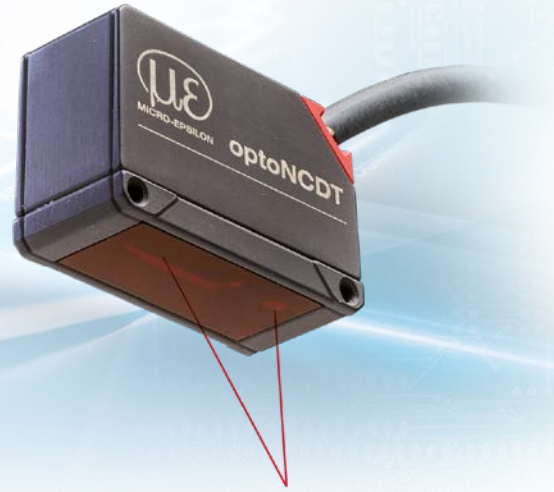

The optoNCDT 1420LL projects a small laser line (LL) onto the measuring object. This compact laser sensor particularly impresses in distance measurements where the sensor or measuring object is moved in the Z-axis direction, such as print head positioning. optoNCDT 1420LL sensors are designed for shiny metallic and structured surfaces, as well as for measurements of materials where the laser beam penetrates. For these surfaces, the small laser line offers significant advantages, as it optically averages and compensates for irregularities such as structure and roughness. In addition to optical averaging, special software algorithms filter out interferences caused by surface roughness, defects, depressions or the smallest of holes. Especially on metals, they achieve more stable and reliable measurement results than point sensors.

The optoNCDT 1420LL sensors offer a unique combination of speed, size, performance and application versatility in the class of compact triangulation sensors. The sensor is equipped with integrated controller and is used in restricted installation spaces or dynamic applications. The selectable connection type (cable or pigtail) and the internal controller reduce the installation effort to a minimum. The Active Surface Compensation (ASC) provides stable distance signal control.

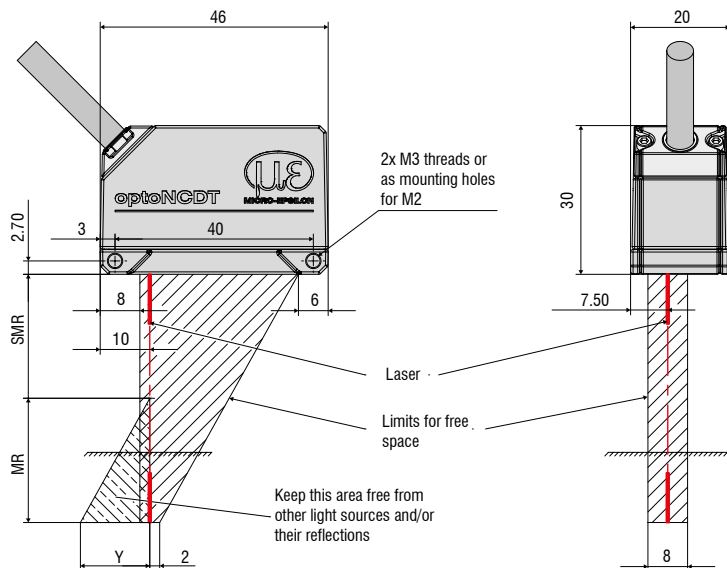

(dimensions in mm, not to scale)

Connector (sensor side)

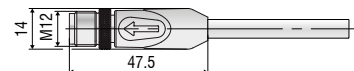

MR	SMR	Y
10	20	10
25	25	21
50	35	28

Model		ILD1420-10LL	ILD1420-25LL	ILD1420-50LL
Measuring range		10 mm	25 mm	50 mm
Start of measuring range		20 mm	25 mm	35 mm
Mid of measuring range		25 mm	37.5 mm	60 mm
End of measuring range		30 mm	50 mm	85 mm
Measuring rate ¹⁾		5 adjustable stages: 4 kHz / 2 kHz / 1 kHz / 0.5 kHz / 0.25 kHz		
Linearity		< ±8 μm	< ±20 μm	< ±40 μm
		< ±0.08 % FSO		
Repeatability ²⁾		0.5 μm	1 μm	2 μm
Temperature stability		±0.015 % FSO / K		
Light spot diameter (±10 %) ³⁾	SMR	140 x 720 μm	220 x 960 μm	240 μm x 1250 μm
	MMR	65 x 680 μm	80 x 970 μm	130 μm x 1450 μm
	EMR	140 x 660 μm	240 x 1000 μm	380 μm x 1650 μm
	smallest diameter	65 x 680 μm with 25 mm	80 x 970 μm with 37.5 mm	110 x 1400 μm with 52.5 mm
Light source		Semiconductor laser < 1 mW, 670 nm (red)		
Laser safety class		Class 2 according to DIN EN 60825-1: 2015-07		
Permissible ambient light ⁴⁾		50,000 lx		
Supply voltage		11 ... 30 VDC		
Power consumption		< 2 W (24 V)		
Signal input		1 x HTL laser on/off; 1 x HTL multifunction input: trigger in / zero setting / mastering / teach		
Digital interface		RS422 (16 bit) / PROFINET ⁵⁾ / EtherNet/IP ⁵⁾		
Analog output		4 ... 20 mA / 1 ... 5 V with PCF1420-3/U cable (12 bit, freely scalable within the measuring range) ⁶⁾		
Switching output		1 x error output: npn, pnp, push pull		
Connection		integrated cable 3 m, open ends, min. bending radius 30 mm (fixed installation); or integrated pigtail 0.3 m with 12-pin M12 plug (see accessories for suitable connection cable)		
Mounting		Screw connection via two mounting holes		
Temperature range	Storage	-20 ... +70 °C (non-condensing)		
	Operation	0 ... +50 °C (non-condensing)		
Shock (DIN EN 60068-2-27)		15 g / 6 ms in 3 axes, 1000 shocks each		
Vibration (DIN EN 60068-2-6)		20 g / 20 ... 500 Hz in 3 axes, 2 directions and 10 cycles each		
Protection class (DIN EN 60529)		IP65		
Material		Aluminum housing		
Weight		approx. 60 g (incl. pigtail), approx. 145 g (incl. cable)		
Control and display elements		Select button: zero, teach, factory setting; web interface for setup ⁷⁾ : selectable presets, peak selection, video signal, freely selectable averaging, data reduction, setup management; 2 x color LEDs for power / status		

FSO = Full Scale Output

SMR = Start of measuring range, MMR = Mid of measuring range, EMR = End of measuring range

The specified data apply to a white, diffuse reflecting surface (reference ceramic)

¹⁾ Factory setting 2 kHz, modifying the factory setting requires the IF2001/USB converter (see accessories)

²⁾ Measuring rate 2 kHz, median 9

³⁾ Light spot diameter with line-shaped laser determined based on the emulated 90/10 knife-edge method

⁴⁾ Illuminant: light bulb

⁵⁾ Optional connection via interface module (see accessories)

⁶⁾ D/A conversion is executed with 12 bit

⁷⁾ Connection to PC via IF2001/USB (see accessories)



Precise laser sensors with small laser line optoNCDT 1900LL

- For shiny metallic, rough and structured surfaces
- Measuring rate up to 10 kHz
- INTER FACE** Analog (U/I) / RS422 / PROFINET / EtherNet/IP
- ASC** Advanced Surface Compensation
- Repeatability <math>< 0.1 \mu\text{m}</math>
- Highest immunity to ambient light



Laser sensor with small laser line

The optoNCDT 1900LL projects a small laser line onto the measuring object. This compact laser sensor particularly impresses in distance measurements where the sensor or measuring object is moved in the Z-axis direction, such as print head positioning. optoNCDT 1900LL sensors are designed for shiny metallic and structured surfaces, as well as for measurements of materials where the laser beam penetrates.

For these surfaces, the small laser line offers significant advantages, as it optically averages and compensates for irregularities such as structure and roughness. In addition to optical averaging, special software algorithms filter out interferences caused by surface roughness, defects, depressions or the smallest of holes.

Especially on metals, they achieve more stable and reliable measurement results than point sensors. The high-performance controller integrated in the optoNCDT 1900LL sensor enables fast and highly precise processing and output of measurement values. In addition, the sensor has the highest resistance to ambient light in its class and can be used in strongly illuminated environments up to 50,000 lux. The optoNCDT 1900LL is used wherever high precision and reliability are required, e.g., in challenging automation tasks, automotive production, automotive production, 3D printing and in measuring machines.

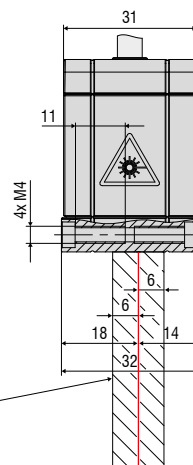
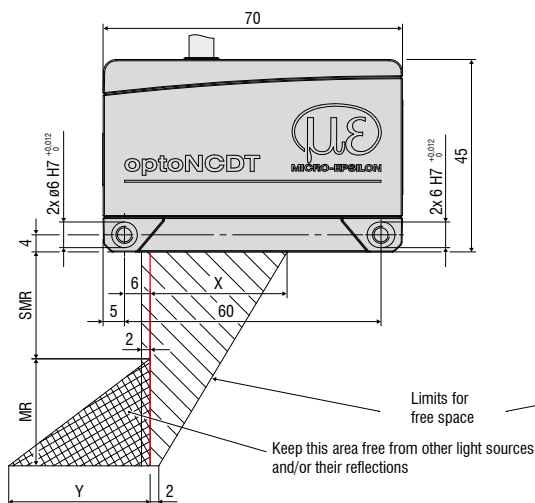

Connector (sensor side)

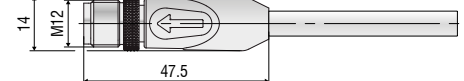

MR	SMR	X	Y
2	15	23	3
10	20	33	14
25	25	33	33
50	40	36	45

(dimensions in mm, not to scale)

Model		ILD1900-2LL	ILD1900-10LL	ILD1900-25LL	ILD1900-50LL
Measuring range		2 mm	10 mm	25 mm	50 mm
Start of measuring range		15 mm	20 mm	25 mm	40 mm
Mid of measuring range		16 mm	25 mm	37.5 mm	65 mm
End of measuring range		17 mm	30 mm	50 mm	90 mm
Measuring rate ¹⁾		continuously adjustable between 0.25 ... 10 kHz			
		7 adjustable stages: 10 kHz / 8 kHz / 4 kHz / 2 kHz / 1.0 kHz / 500 Hz / 250 Hz			
Linearity ²⁾		< ±1 μm	< ±2 μm	< ±5 μm	< ±10 μm
		< ±0.05 % FSO	< ±0.02 % FSO	< ±0.02 % FSO	< ±0.02 % FSO
Repeatability ³⁾		< 0.1 μm	< 0.4 μm	< 0.8 μm	< 1.6 μm
Temperature stability ⁴⁾		±0.005 % FSO / K			
Light spot diameter (±10 %) ⁵⁾	SMR	55 x 480 μm	125 x 730 μm	210 x 950 μm	235 μm x 1280 μm
	MMR	40 x 460 μm	55 x 690 μm	80 x 970 μm	125 μm x 1500 μm
	EMR	55 x 440 μm	125 x 660 μm	220 x 1000 μm	325 μm x 1740 μm
	smallest diameter	40 x 460 μm with 16 mm	55 x 690 μm with 25 mm	80 x 970 μm with 37.5 mm	115 x 1450 μm with 59 mm
Light source		Semiconductor laser < 1 mW, 670 nm (red)			
Laser safety class		Class 2 in accordance with DIN EN 60825-1: 2015-07			
Permissible ambient light		50,000 lx			
Supply voltage		11 ... 30 VDC			
Power consumption		< 3 W (24 V)			
Signal input		1 x HTL/TTL laser on/off; 1 x HTL/TTL multi-function input: trigger in, slave in, zero setting, mastering, teach-in; 1 x RS422 synchronization input: trigger in, sync in, master/slave, master/slave alternating			
Digital interface		RS422 (18 bit) / PROFINET ⁶⁾ / EtherNet/IP ⁶⁾			
Analog output		4 ... 20 mA / 0 ... 5 V / 0 ... 10 V (16 bit, freely scalable within the measuring range)			
Switching output		2x switching outputs (error & limit value): npn, pnp, push pull			
Synchronization		possible for simultaneous or alternating measurements			
Connection		integrated cable 3 m, open ends, min. bending radius 30 mm (fixed installation); or integrated pigtail 0.3 m with 17-pin M12 plug; optional extension to 3 m / 6 m / 9 m / 15 m possible (suitable connection cable see Accessories)			
Temperature range	Storage	-20 ... +70 °C (non-condensing)			
	Operation	0 ... +50 °C (non-condensing)			
Shock (DIN EN 60068-2-27)		15 g / 6 ms in 3 axes			
Vibration (DIN EN 60068-2-6)		30 g / 20 ... 500 Hz			
Protection class (DIN EN 60529)		IP67			
Material		Aluminum housing			
Weight		approx. 185 g (incl. pigtail), approx. 300 g (incl. cable)			
Control and display elements		Select & function keys: interface selections, mastering (zero), teach, presets, quality slider, frequency selection, factory settings; web interface for setup ⁷⁾ : application-specific presets, peak selection, video signal, freely selectable averaging possibilities, data reduction, setup management; 2 x color LEDs for power / status			

FSO = Full Scale Output

SMR = Start of measuring range, MMR = Mid of measuring range, EMR = End of measuring range

The specified data apply to a white, diffuse reflecting surface (Micro-Epsilon reference ceramic for ILD sensors)

¹⁾ Factory setting: measuring rate 4 kHz, median 9; modifying the factory setting requires the IF2001/USB converter (see accessories)

²⁾ Relates to digital output

³⁾ Typical value with measurements at 4 kHz and median 9

⁴⁾ Relates to digital output in mid of measuring range

⁵⁾ Light spot diameter with line-shaped laser determined based on the emulated 90/10 knife-edge method

⁶⁾ Connection via interface module (see accessories)

⁷⁾ Connection to PC via IF2001/USB (see accessories)



High-performance laser sensors with small laser line optoNCDT 2300LL

- For shiny metallic, rough and structured surfaces
- Adjustable measuring rate up to 49.14 kHz
- INTERFACE** Analog (U/I) / RS422 / EtherNet / EtherCAT / PROFINET / EtherNet/IP
- ARTSC** Advanced Real Time Surface Compensation
- Resolution 0.03 μm



The optoNCDT 2300LL projects a small laser line (LL) onto the measuring object. This powerful laser sensor particularly impresses in high precision distance measurements where the sensor or measuring object is moved in the Z-axis direction, such as print head positioning. optoNCDT 2300LL sensors are designed for shiny metallic and structured surfaces, as well as for measurements of materials where the laser beam penetrates. For these surfaces, the small laser line offers significant advantages, as it optically averages and compensates for irregularities such as structure and roughness.

Especially on metals, they achieve more stable and reliable measurement results than point sensors. The A-RTSC (Advanced Real Time Surface Compensation), with its improved dynamic range, enables a more precise real time surface compensation during the measurement process.

The optoNCDT 2300 laser sensors can be operated via a web interface which offers multiple possibilities in order to process measured values and signals, e.g., peak selection, filter and masking of the video signal.

In addition to optical averaging, special software algorithms filter out interferences caused by surface roughness, defects, depressions or the smallest of holes.

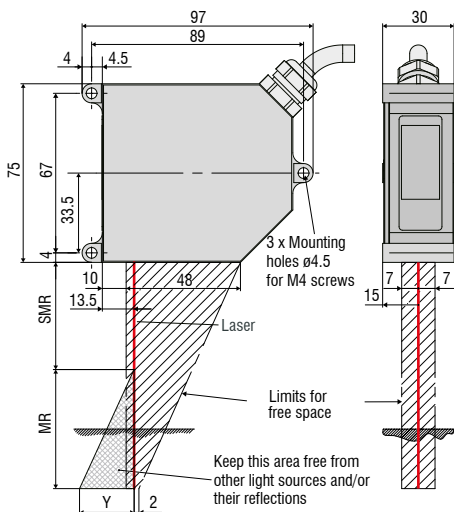

Connector (sensor side)

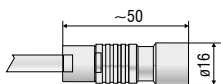

MR	SMR	Y
2	24	1.5
10	30	6.5
20	40	10.0
50	45	23.0

(dimensions in mm, not to scale)

Model	ILD2300-2LL	ILD2300-10LL	ILD2300-20LL	ILD2300-50LL
Measuring range ¹⁾	2 (2) mm	10 (5) mm	20 (10) mm	50 (25) mm
Start of measuring range ¹⁾	24 (24) mm	30 (35) mm	40 (50) mm	45 (70) mm
Mid of measuring range ¹⁾	25 (25) mm	35 (37.5) mm	50 (55) mm	70 (82.5) mm
End of measuring range ¹⁾	26 (26) mm	40 (40) mm	60 (60) mm	95 (95) mm
Measuring rate	7 adjustable stages: 49.14 kHz ²⁾ / 30 kHz / 20 kHz / 10 kHz / 5 kHz / 2.5 kHz / 1.5 kHz			
Linearity	< ±0.6 μm	< ±2 μm	< ±4 μm	< ±10 μm
	< ±0.03 % FSO	< ±0.02 % FSO		
Resolution ³⁾	0.03 μm	0.15 μm	0.3 μm	0.8 μm
Light spot diameter (± 10 %)	SMR	85 x 240 μm	120 x 405 μm	185 x 485 μm
	MMR	24 x 280 μm	35 x 585 μm	55 x 700 μm
	EMR	64 x 400 μm	125 x 835 μm	195 x 1200 μm
Light source	Semiconductor laser < 1 mW, 670 nm (red)			
Laser safety class	Class 2 in accordance with DIN EN 60825-1: 2015-07			
Permissible ambient light	10,000...40,000 lx			
Supply voltage	11 ... 30 VDC			
Power consumption	< 3 W (24 V)			
Signal input	Laser on/off, sync in, trigger in			
Digital interface	RS422 (16 bit) / Ethernet / EtherCAT / PROFINET ⁴⁾ / EtherNet/IP ⁴⁾			
Analog output ⁴⁾	4 ... 20 mA / 0 ... 5 V / 0 ... 10 V / ±5 V / ±10 V			
Synchronization	possible for simultaneous or alternating measurements			
Connection	integrated pigtail 0.25 m with 14-pin cable connector, min. bending radius 30 mm (fixed installation); optional extension to 3 m / 6 m / 9 m possible (see accessories for suitable connection cable)			
Mounting	Screw connection via three mounting holes			
Temperature range	Storage	-20 ... +70 °C (non-condensing)		
	Operation	0 ... +50 °C (non-condensing)		
Shock (DIN EN 60068-2-27)	15 g / 6 ms in 3 axes			
Vibration (DIN EN 60068-2-6)	2 g / 20 ... 500 Hz			
Protection class (DIN EN 60529)	IP65			
Material	Die-cast zinc housing			
Weight	approx. 550 g (incl. pigtail)			
Control and display elements	Web interface for setup: user management, measurement settings, data output, measurement control, parameters, extras; 2 x color LEDs for Status / Ethernet and EtherCAT			

FSO = Full Scale Output

SMR = Start of measuring range, MMR = Mid of measuring range, EMR = End of measuring range

The specified data apply to white, diffuse reflecting surfaces (Micro-Epsilon reference ceramic for ILD sensors)

¹⁾ Value in brackets is valid for a measuring rate of 49.14 kHz





²⁾ Measuring rate of 49.14 kHz with reduced measuring range (in brackets)

³⁾ Measuring rate of 20 kHz

⁴⁾ Connection via interface module (see accessories)



Blue Laser sensors for large measuring ranges optoNCDT 1710BL

-  For red-hot glowing, organic and transparent surfaces
-  Adjustable measuring rate up to 2.5 kHz
-  **INTERFACE** Analog (U/I) / RS422
-  **RTSC** Real Time Surface Compensation
-  Resolution 7.5 μm



The optoNCDT 1710BL sensors based on the patented Blue Laser Technology are used for measurement tasks where large measuring ranges or distances from the measuring object are required. These large distances enable measurements on hot objects and red-hot glowing steel and silicon.

These sensors are equipped with high-end lenses, new intelligent laser control and innovative evaluation algorithms. This is how they achieve high accuracy and signal stability.

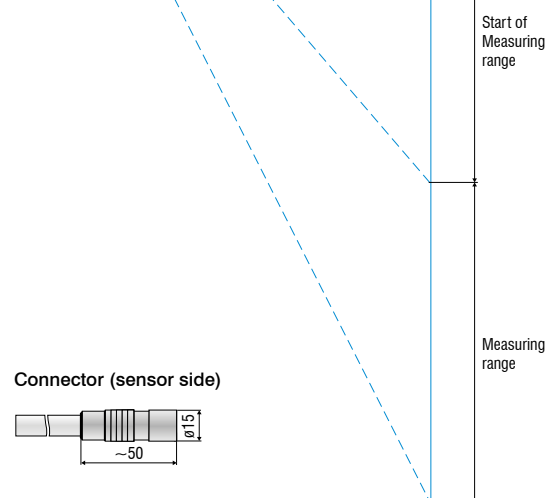
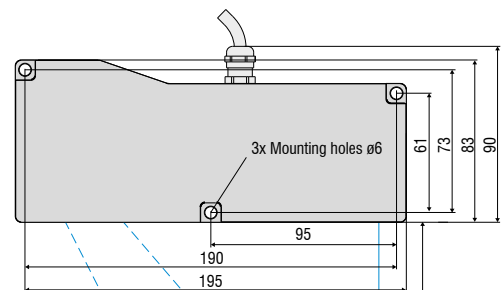

(dimensions in mm, not to scale)

Model		ILD1710-50BL	ILD1710-1000BL
Measuring range		50 mm	1000 mm
Start of measuring range		550 mm	1000 mm
Mid of measuring range		575 mm	1500 mm
End of measuring range		600 mm	2000 mm
Measuring rate		4 adjustable stages: 2.5 kHz / 1.25 kHz / 625 Hz / 312.5 Hz	
Linearity		< ±50 μm	< ±1000 μm
		< ±0.1 % FSO	
Resolution ¹⁾		7.5 μm	100 μm
Light spot diameter (±10 %)	SMR		
	MMR	400 x 500 μm	2500 ... 5000 μm
	EMR		
Light source		Semiconductor laser <1 mW, 405 nm (blue violet)	
Laser safety class		Class 2 in accordance with DIN EN 60825-1: 2015-07	
Permissible ambient light		10,000 lx	
Supply voltage		11 ... 30 VDC	
Max. current consumption		150 mA (24 V)	
Signal input		Zero, laser on/off	
Digital interface		RS422 (14 bit) / USB ²⁾	
Analog output		4 ... 20 mA / 0 ... 10 V	
Switching output		1 x error / 2 x limit values (configurable)	
Synchronization		possible for simultaneous or alternating measurements	
Connection		integrated pigtail 0.25 m with 14-pin ODU plug, min. bending radius 30 mm (see accessories for suitable connection cable)	
Mounting		Screw connection via three mounting holes	
Temperature range	Storage	-20 ... +70 °C (non-condensing)	
	Operation	0 ... +50 °C (non-condensing)	
Shock (DIN EN 60068-2-27)		15 g / 6 ms in 3 axes	
Vibration (DIN EN 60068-2-6)		2 g / 20 ... 500 Hz	
Protection class (DIN EN 60529)		IP65	
Material		Aluminum housing	
Weight		approx. 800 g (incl. pigtail)	
Control and display elements		Select & function keys: output type, measuring rate, type of averaging, averaging number, error analog, synchronization, operation mode, trigger mode, baud rate, data format; measurement chart via PC using the ILD1700 Tool; 5 x color LEDs for status display	

FSO = Full Scale Output

SMR = Start of measuring range, MMR = Mid of measuring range, EMR = End of measuring range

The specified data apply to white, diffuse reflecting surfaces (Micro-Epsilon reference ceramic for ILD sensors)

¹⁾ Measuring rate of 2.5 kHz, without averaging

²⁾ USB optional via cable PC 1700-3/USB (see accessories)







Patented Blue Laser Technology

Measurement tasks involving Blue Laser sensors on red-hot glowing objects exceeding 700 °C and transparent objects such as plastics, adhesives and glass are patented by Micro-Epsilon. On these surfaces, the optoNCDT Blue Laser models achieve excellent signal stability and high precision measurement results.



Blue Laser sensors for industry & automation

optoNCDT 1750BL

-  For red-hot glowing, organic and transparent surfaces
-  Adjustable measuring rate up to 7.5 kHz
- INTERFACE**  Analog
RS422 / PROFINET / EtherNet/IP
- RTSC**  Real Time Surface Compensation
-  Repeatability 0.8 μm



optoNCDT 1750BL Blue Laser sensors are designed for high speed displacement, distance and position measurements. These sensors are equipped with innovative high performance lenses, laser control and evaluation algorithms to ensure precise measurements on different surfaces and materials.

The patented Blue Laser Technology offers decisive advantages compared to red-diode laser sensors. Since the blue laser point does not penetrate the surface, the target is sharply imaged onto the sensor element. This makes it possible to achieve high resolution and reliable signal stability.

Connector (sensor side)

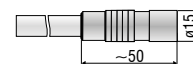

optoNCDT 1750BL (20/200 mm)

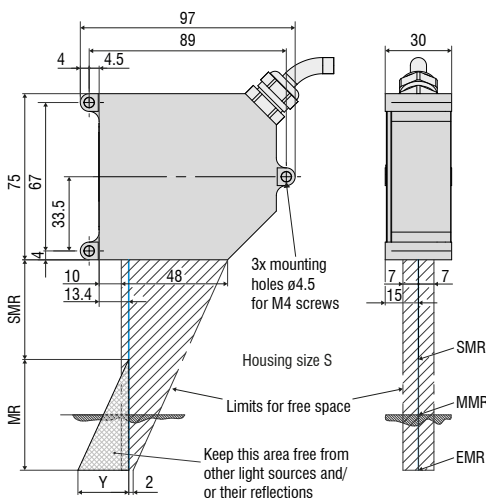

MR	SMR	Y
20	40	12
200	100	70
500	200	180
750	200	270

optoNCDT 1750BL (500/750 mm)

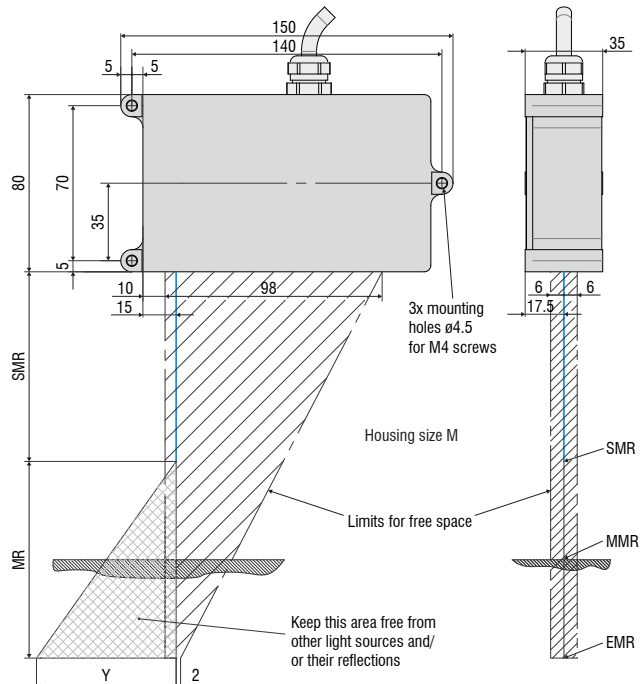

(dimensions in mm, not to scale)

Model		ILD1750-20BL	ILD1750-200BL	ILD1750-500BL	ILD1750-750BL
Measuring range		20 mm	200 mm	500 mm	750 mm
Start of measuring range		40 mm	100 mm	200 mm	200 mm
Mid of measuring range		50 mm	200 mm	450 mm	575 mm
End of measuring range		60 mm	300 mm	700 mm	950 mm
Measuring rate ¹⁾		continuously adjustable between 0.3 ... 7.5 kHz			
		6 adjustable stages: 7.5 kHz / 5 kHz / 2.5 kHz / 1.25 kHz / 625 Hz / 300 Hz			
Linearity		< ±12 μm	< ±160 μm	< ±350 μm	< ±670 μm
		< ±0.06 % FSO	< ±0.08 % FSO	< ±0.07 % FSO	< ±0.09 % FSO
Repeatability ²⁾		0.8 μm	15 μm	20 μm	45 μm
Light spot diameter (±10 %)	SMR	320 μm	1300 μm	1500 μm	1500 μm
	MMR	45 μm			
	EMR	320 μm			
Light source		Semiconductor laser <1 mW, 405 nm (blue violet)			
Laser safety class		Class 2 in accordance with DIN EN 60825-1: 2015-07			
Permissible ambient light		10,000 lx			
Supply voltage		11 ... 30 VDC			
Power consumption		< 3 W (24 V)			
Signal input		1x HTL/TTL laser on/off; 1x HTL/TTL multi-function input: trigger in, slave in, zero setting, mastering, teach-in; 1x RS422 synchronization input: trigger in, sync in, master-slave, master-slave alternating			
Digital interface		RS422 (16 bit) / PROFINET ³⁾ / EtherNet/IP ³⁾			
Analog output		4 ... 20 mA / 0 ... 5 V / 0 ... 10 V (16 bit, freely scalable within the measuring range)			
Switching output		2x switching outputs (error & limit value): npn, pnp, push pull			
Synchronization		possible for simultaneous or alternating measurements			
Connection		integrated pigtail 0.25 m with 14-pin ODU plug; optional extension to 3 m / 10 m (see accessories for suitable connection cable)			
Mounting		Screw connection via three mounting holes			
Temperature range	Storage	-20 ... +70 °C			
	Operation	0 ... +50 °C			
Shock (DIN EN 60068-2-27)		15 g / 6 ms in 3 axes			
Vibration (DIN EN 60068-2-6)		2 g / 20 ... 500 Hz			
Protection class (DIN EN 60529)		IP65			
Material		Die-cast zinc housing		Aluminum housing	
Weight		approx. 550 g (incl. pigtail)			approx. 600 g (incl. pigtail)
Control and display elements		Select & function keys: interface selections, mastering (zero), teach, presets, quality slider, frequency selection, factory settings; web interface for setup ⁴⁾ : application-specific presets, peak selection, video signal, freely selectable averaging possibilities, data reduction, setup management; 2 x color LEDs for power / status			

FSO = Full Scale Output

SMR = Start of measuring range, MMR = Mid of measuring range, EMR = End of measuring range

The specified data apply to white, diffuse reflecting surfaces (Micro-Epsilon reference ceramic for ILD sensors)

¹⁾ Factory setting 5 kHz, modifying the factory setting requires the IF2001/USB converter (see accessories)

²⁾ Measuring rate 5 kHz, median 9

³⁾ Optional connection via interface module (see accessories)

⁴⁾ Connection to PC via IF2001/USB (see accessories)









Patented Blue Laser Technology

Measurement tasks involving Blue Laser sensors on red-hot glowing objects exceeding 700 °C and transparent objects such as plastics, adhesives and glass are patented by Micro-Epsilon. On these surfaces, the optoNCDT Blue Laser models achieve excellent signal stability and high precision measurement results.



Highly dynamic Blue Laser sensors optoNCDT 2300BL

-  For red-hot glowing, organic and transparent surfaces
-  Adjustable measuring rate up to 49.14 kHz
- INTERFACE**  Analog (U/I) / RS422 / EtherNet / EtherCAT / PROFINET / EtherNet/IP
- ARTSC**  Advanced Real Time Surface Compensation
-  Resolution 0.03 μm
-  For diffuse and reflective surfaces



optoNCDT 2300BL Blue Laser sensors are designed for fast and high resolution measurements of displacement, distance and position. The optoNCDT 2300 is the high-end model of Micro-Epsilon laser triangulation sensors and offers an adjustable measuring rate of up to 49.14 kHz. The entire electronics is integrated in a compact sensor which is a worldwide unique feature in this sensor class.

The Blue Laser Technology patented by Micro-Epsilon offers decisive advantages compared to red-diode laser sensors. Since the blue laser point does not penetrate the surface, the target is sharply imaged onto the sensor element. This makes it possible to achieve high resolution and reliable signal stability.

optoNCDT 2310-50BL

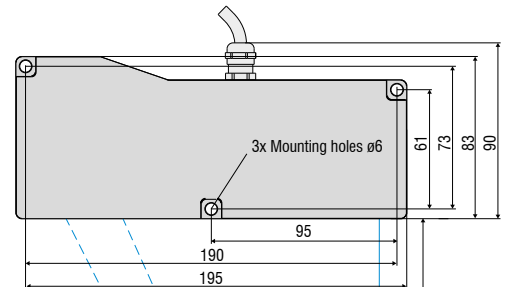
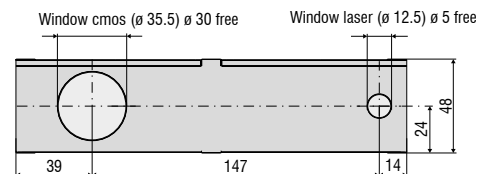

(dimensions in mm, not to scale)

Connector (sensor side)

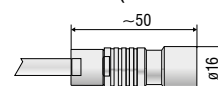

optoNCDT 2300-2BL / 2300-5BL / 2300-10BL

Diffuse reflection

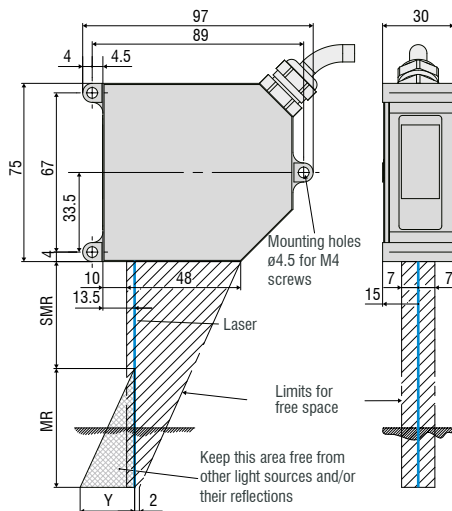

MR	SMR	Y
2	24	1.5
5	24	3.5
10	30	6.5

optoNCDT 2300-2BL / 2300-5BL / 2300-10BL

Direct reflection

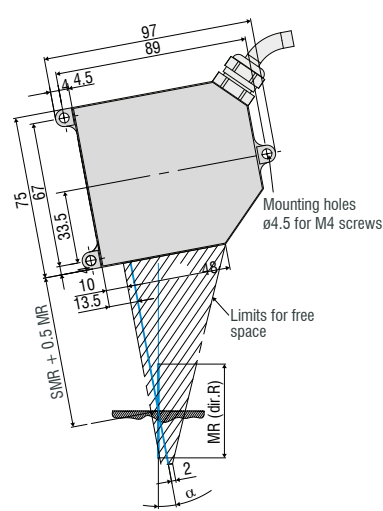

MR	SMR + 0.5 MR	α
2	25	20.5°
5	26.5	20°
10	35	17.5°

Model		ILD2300-2BL	ILD2300-5BL	ILD2300-10BL	ILD2310-50BL
Measuring range ¹⁾		2 (2) mm	5 (2) mm	10 (5) mm	50 (25) mm
Start of measuring range ¹⁾		24 (24) mm	24 (24) mm	30 (35) mm	550 (575) mm
Mid of measuring range ¹⁾		25 (25) mm	26.5 (25) mm	35 (37.5) mm	575 (587.5) mm
End of measuring range ¹⁾		26 (26) mm	29 (26) mm	40 (40) mm	600 (600) mm
Measuring rate		7 adjustable stages: 49.14 kHz ²⁾ / 30 kHz / 20 kHz / 10 kHz / 5 kHz / 2.5 kHz / 1.5 kHz			
Linearity		< ±0.6 μm	< ±1.5 μm	< ±2 μm	< ±40 μm
		< ±0.03 % FSO		< ±0.02 % FSO	< ±0.08 % FSO
Resolution ³⁾		0.03 μm	0.08 μm	0.15 μm	7.5 μm
Light spot diameter (±10 %)	SMR	70 x 80 μm	200 x 200 μm	75 x 85 μm	400 ... 500 μm
	MMR	20 x 20 μm	20 x 20 μm	32 x 45 μm	
	EMR	80 x 100 μm	200 x 400 μm	110 x 160 μm	
Light source		Semiconductor laser <1 mW, 405 nm (blue violet)			
Laser safety class		Class 2 in accordance with DIN EN 60825-1: 2015-07			
Permissible ambient light		10,000 lx			
Supply voltage		11 ... 30 VDC			
Power consumption		< 3 W (24 V)			
Signal input		Laser on/off, sync in, trigger in			
Digital interface		RS422 (16 bit) / Ethernet / EtherCAT / PROFINET ⁴⁾ / EtherNet/IP ⁴⁾			
Analog output ⁴⁾		4 ... 20 mA / 0 ... 5 V / 0 ... 10 V / ±5 V / ±10 V			
Synchronization		possible for simultaneous or alternating measurements			
Connection		integrated pigtail 0.25 m with 14-pin cable connector, min. bending radius 30 mm (fixed installation); optional extension to 3 m / 6 m / 9 m possible (see accessories for suitable connection cable)			
Mounting		Screw connection via three mounting holes			
Temperature range	Storage	-20 ... +70 °C (non-condensing)			
	Operation	0 ... +50 °C (non-condensing)			
Shock (DIN EN 60068-2-27)		15 g / 6 ms in 3 axes			
Vibration (DIN EN 60068-2-6)		2 g / 20 ... 500 Hz			
Protection class (DIN EN 60529)		IP65			
Material		Die-cast zinc housing			
Weight		approx. 550 g (incl. pigtail)			approx. 800 g (incl. pigtail)
Control and display elements		Web interface for setup: user management, measurement settings, data output, measurement control, parameters, extras; 2 x color LEDs for Status / Ethernet and EtherCAT			

FSO = Full Scale Output

SMR = Start of measuring range, MMR = Mid of measuring range, EMR = End of measuring range

The specified data apply to white, diffuse reflecting surfaces (Micro-Epsilon reference ceramic for ILD sensors)

¹⁾ Value in brackets is valid for a measuring rate of 49.14 kHz

²⁾ Measuring rate of 49.14 kHz with reduced measuring range (in brackets)

³⁾ Measuring rate of 20 kHz

⁴⁾ Connection via interface module (see accessories)



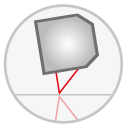

Patented Blue Laser Technology

Measurement tasks involving Blue Laser sensors on red-hot glowing objects exceeding 700 °C and transparent objects such as plastics, adhesives and glass are patented by Micro-Epsilon. On these surfaces, the optoNCDT Blue Laser models achieve excellent signal stability and high precision measurement results.



Laser sensors for specular surfaces optoNCDT 1750DR

-  For mirrored surfaces
-  Measuring rate up to 7.5 kHz
- INTERFACE** Analog (U/I)
RS422 / PROFINET / EtherNet/IP
- RTSC** Real Time Surface Compensation
-  Repeatability 0.1 μm



The optoNCDT 1750DR sensors are designed for measurements with specular objects and are used for distance measurements with reflective plastics, mirror glass or polished metal. The sensor's tilted alignment makes the angle of incidence equal to the angle of reflection. The sensor compensates for the radiation intensity of the directly reflected radiation and thus enables high signal quality.

These sensors are equipped with a laser of class 1 whose radiated power is at max. 390 μW . As this laser radiation does not represent a hazard to the eye, corresponding protective measures are not necessary.

The design is identical to the optoNCDT 1750 standard series and so can even be integrated into restricted installation spaces. A mounting template is included in the scope of supply.

The optoNCDT 1750DR sensors feature RTSC real time surface compensation, which determines the reflectance of the target during ongoing exposure and adjusts it in real time. All laser sensors are operated using an intuitive web interface. Due to the selectable setting and evaluation possibilities, they meet the requirements for use in industrial applications with high dynamics.

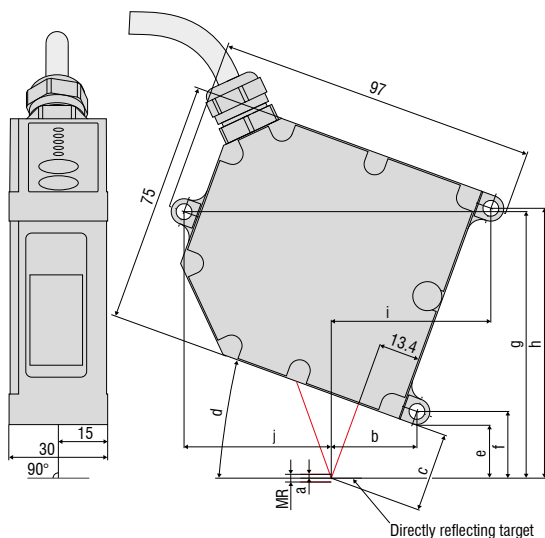

(dimensions in mm, not to scale)

Connector (sensor side)

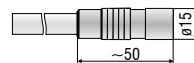

MR	a	b	c	d	e	f	g	h	i	j
2	1	26.5	25	20°	16.7	20.7	82.6	83.7	49.5	45.6
10	5	29	35.5	17.6°	28.3	32.3	91.1	96.2	49.2	45.7
20	10	30.9	63.5	11.5°	58.6	62.6	113.2	128.2	44.3	49.6

Model		ILD1750-2DR	ILD1750-10DR	ILD1750-20DR
Measuring range		2 mm	10 mm	20 mm
Start of measuring range		24 mm	30.5 mm	53.5 mm
Mid of measuring range		25 mm	35.5 mm	63.5 mm
End of measuring range		26 mm	40.5 mm	73.5 mm
Measuring rate ¹⁾		continuously adjustable between 0.3 ... 7.5 kHz		
		6 adjustable stages: 7.5 kHz / 5 kHz / 2.5 kHz / 1.25 kHz / 625 Hz / 300 Hz		
Linearity		< ±1.6 μm	< ±6 μm	< ±12 μm
		< ±0.08 % FSO		
Repeatability ²⁾		0.1 μm	0.4 μm	0.8 μm
Tilt angle		20°	17.6°	11.5°
Light spot diameter (±10 %)	SMR	80 μm	110 μm	320 μm
	MMR	35 μm	50 μm	45 μm
	EMR	80 μm	110 μm	320 μm
Light source		Semiconductor laser < 0.39 mW, 670 nm (red)		
Laser safety class		Class 1 in accordance with DIN EN 60825-1: 2015-07		
Permissible ambient light		10,000 lx		
Supply voltage		11 ... 30 VDC		
Power consumption		< 3 W (24 V)		
Signal input		1 x HTL/TTL laser on/off; 1 x HTL/TTL multi-function input: trigger in, slave in, zero setting, mastering, teach-in; 1 x RS422 synchronization input: trigger in, sync in, master/slave, master/slave alternating		
Digital interface		RS422 (18 bit) / PROFINET ³⁾ / EtherNet/IP ³⁾		
Analog output		4 ... 20 mA / 0 ... 5 V / 0 ... 10 V (16 bit, freely scalable within the measuring range)		
Switching output		2x switching outputs (error & limit value): npn, pnp, push pull		
Synchronization		possible for simultaneous or alternating measurements		
Connection		integrated cable 0.25 m with 14-pin cable connector, min. bending radius 30 mm (fixed installation); optional extension to 3 m / 10 m possible (see accessories for suitable connection cable)		
Mounting		Screw connection via three mounting holes		
Temperature range	Storage	-20 ... +70 °C (non-condensing)		
	Operation	0 ... +50 °C (non-condensing)		
Shock (DIN EN 60068-2-27)		15 g / 6 ms in 3 axes		
Vibration (DIN EN 60068-2-6)		2 g / 20 ... 500 Hz		
Protection class (DIN EN 60529)		IP65		
Material		Die-cast zinc housing		
Weight		approx. 550 g (incl. pigtail)		
Control and display elements		Select & function keys: interface selections, mastering (zero), teach, presets, quality slider, frequency selection, factory settings; web interface for setup ⁴⁾ : application-specific presets, peak selection, video signal, freely selectable averaging possibilities, data reduction, setup management; 2 x color LEDs for power / status		

FSO = Full Scale Output

SMR = Start of measuring range, MR = Mid of measuring range, MR = End of measuring range

The specified data apply to directly reflecting surfaces

¹⁾ Factory setting 5 kHz, modifying the factory setting requires the IF2001/USB converter (see accessories)





²⁾ Measuring rate 5 kHz, median 9

³⁾ Connection via interface module (see accessories)

⁴⁾ Connection to PC via IF2001/USB (see accessories)



High precision Blue Laser sensors for reflective surfaces optoNCDT 2300-2DR

-  For mirrored surfaces
-  Adjustable measuring rate up to 49.14 kHz
-  **INTERFACE** Analog (U/I) / RS422 / Ethernet / EtherCAT / PROFINET / EtherNet/IP
-  **A-RTSC** Advanced Real Time Surface Compensation
-  Resolution 0.03 μm



Blue Laser sensor for direct reflection

The optoNCDT 2300-2DR high precision laser triangulation sensor is designed for highly dynamic measurements on reflective and shiny targets. The sensor can be fixed parallel to the measuring object, which greatly simplifies the installation process. Unlike conventional laser triangulation sensors, the optoNCDT 2300-2DR uses the directly reflected light of the laser. During measurements, the blue laser light is directly reflected by the measuring object onto the receiving optics. Due to the blue laser light, the signal on the receiver element is extremely stable, which means the sensor is able to measure to nanometer resolution. An extremely small laser spot size enables the detection of very small objects.

High speed and precision on shiny & reflective surfaces

The optoNCDT 2300-2DR offers an adjustable measuring rate up to 49.14 kHz and so is suitable for dynamic high speed process monitoring. The Advanced Real Time Surface Compensation (A-RTSC) feature is a development of the proven RTSC technology and enables more precise real time surface compensation when measuring onto different surface types.

The sensor is used for production monitoring purposes such as distance measurement of wafers, assembly monitoring of extremely small parts and for distance measurements on annealed glass.

Compact and easy to integrate

The entire electronics is integrated in a compact sensor housing which is a worldwide unique feature in this sensor class. Data output is via Ethernet, RS422 or EtherCAT. If the sensor is operated with the C-Box/2A signal processing unit (optional), an analog output is also available. The entire sensor configuration is handled in a user-friendly web interface.

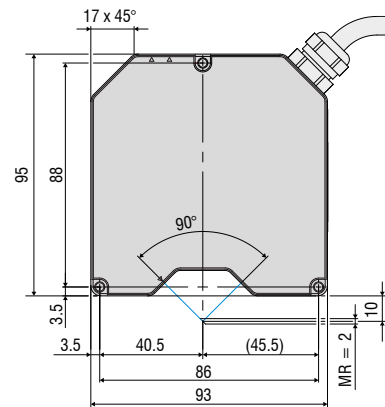

Connector (sensor side)

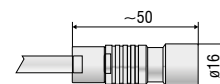

(dimensions in mm, not to scale)

Model	ILD2300-2DR	
Measuring range ¹⁾	2 (1) mm	
Start of measuring range ¹⁾	9 (9) mm	
Mid of measuring range ¹⁾	10 (9.5) mm	
End of measuring range ¹⁾	11 (10) mm	
Measuring rate	7 adjustable stages: 49.14 kHz ²⁾ / 30 kHz / 20 kHz / 10 kHz / 5 kHz / 2.5 kHz / 1.5 kHz	
Linearity	< ±0.6 μm	
	< ±0.03 % FSO	
Resolution ³⁾	0.03 μm	
Temperature stability	±0.01 % FSO / K	
Light spot diameter (±10 %)	SMR	21.6 x 25 μm
	MMR	8.5 x 11 μm
	EMR	22.4 x 23.7 μm
Light source	Semiconductor laser <1 mW, 405 nm (blue violet)	
Laser safety class	Class 2 in accordance with DIN EN 60825-1: 2015-07	
Permissible ambient light	10,000...40,000 lx	
Supply voltage	11 ... 30 VDC	
Power consumption	< 2 W (24 V)	
Signal input	Laser on/off, sync in, trigger in	
Digital interface	RS422 (16 bit) / Ethernet / EtherCAT / PROFINET ⁴⁾ / EtherNet/IP ⁴⁾	
Analog output ⁴⁾	4 ... 20 mA / 0 ... 5 V / 0 ... 10 V / ±5 V / ±10 V	
Synchronization	possible for simultaneous or alternating measurements	
Connection	integrated pigtail 0.25 m with 14-pin cable connector, min. bending radius 30 mm (fixed installation); optional extension to 3 m / 10 m possible (see accessories for suitable connection cable)	
Mounting	Screw connection via three mounting holes	
Temperature range	Storage	-20 ... +70 °C (non-condensing)
	Operation	0 ... +50 °C (non-condensing)
Shock (DIN EN 60068-2-27)	15 g / 6 ms in 3 axes	
Vibration (DIN EN 60068-2-6)	2 g / 20 ... 500 Hz	
Protection class (DIN EN 60529)	IP65	
Material	Aluminum housing	
Weight	approx. 400 g (incl. pigtail)	
Control and display elements	Web interface for setup: user management, measurement settings, data output, measurement control, parameters, extras; 2 x color LEDs for Status / Ethernet and EtherCAT	

FSO = Full Scale Output

SMR = Start of measuring range, MMR = Mid of measuring range, EMR = End of measuring range

The specified data apply to directly reflecting surfaces

¹⁾ Value in brackets is valid for a measuring rate of 49.14 kHz

²⁾ Measuring rate of 49.14 kHz with reduced measuring range (in brackets)

³⁾ Measuring rate 20 kHz

⁴⁾ Optional connection via interface module (see accessories)





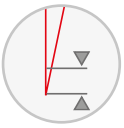

Patented Blue Laser Technology

Measurement tasks involving Blue Laser sensors on red-hot glowing objects exceeding 700 °C and transparent objects such as plastics, adhesives and glass are patented by Micro-Epsilon. On these surfaces, the optoNCDT Blue Laser models achieve excellent signal stability and high precision measurement results.



Long-range sensors for large distances optoNCDT 1710

-  For common surfaces
-  Adjustable measuring rate up to 2.5 kHz
- INTERFACE**  Analog (UI)
RS422
- RTSC**  Real Time Surface Compensation
-  Resolution 7.5 μm



The optoNCDT 1710-50 long-range laser sensors are designed for large measurement distances combined with high precision. The optoNCDT 1710-1000 sensors are even used for measuring ranges up to 1000 mm. Both series measure distances without contact against a wide variety of material surfaces.

Unlike conventional laser triangulation sensors, long-range sensors measure over a large distance from the target which prevents possible collisions. The integrated RTSC enables precise measurements even on changing surfaces.

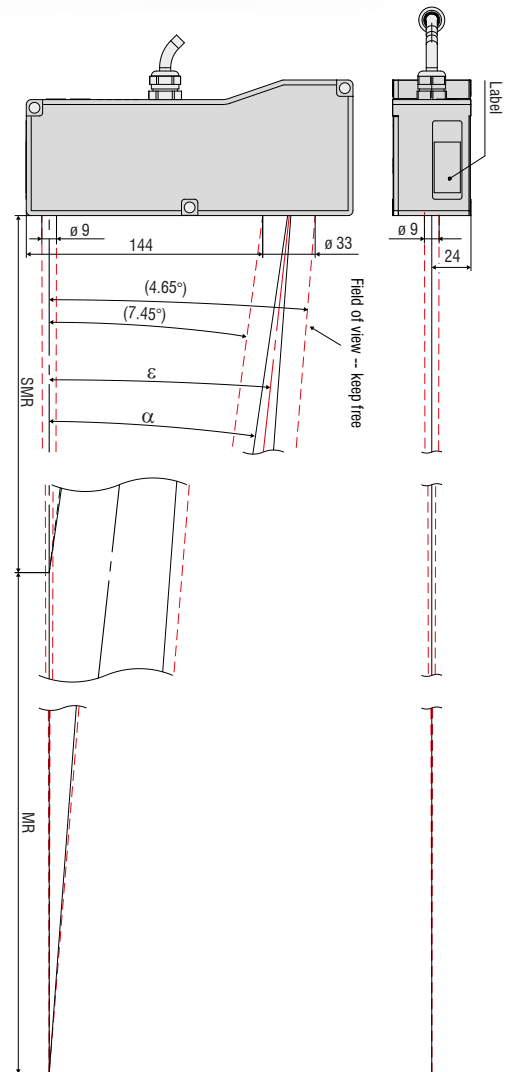
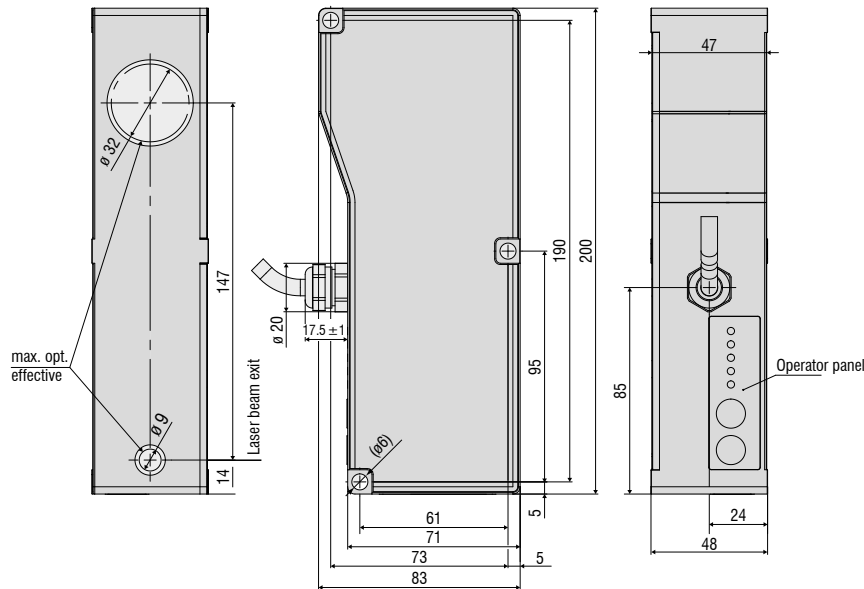

MR	SMR	α	ϵ
50	550	13.35°	15.15°
1000	1000	7.45°	4.65°

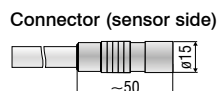

(dimensions in mm, not to scale)

Model		ILD1710-50	ILD1710-1000
Measuring range		50 mm	1000 mm
Start of measuring range		550 mm	1000 mm
Mid of measuring range		575 mm	1500 mm
End of measuring range		600 mm	2000 mm
Measuring rate		4 adjustable stages: 2.5 kHz / 1.25 kHz / 625 Hz / 312.5 Hz	
Linearity		< ±50 μm	< ±1000 μm
		< ±0.1 % FSO	
Resolution ¹⁾		7.5 μm	100 μm
Light spot diameter (± 10 %)	SMR	400 x 500 μm	2500 ... 5000 μm
	MMR		
	EMR		
Light source		Semiconductor laser < 1 mW, 670 nm (red)	
Laser safety class		Class 2 in accordance with DIN EN 60825-1: 2015-07	
Permissible ambient light		10,000 lx	
Supply voltage		11 ... 30 VDC	
Max. current consumption		150 mA (24 V)	
Signal input		Zero, laser on/off	
Digital interface		RS422 (14 bit) / USB ²⁾	
Analog output		4 ... 20 mA / 0 ... 10 V	
Switching output		1 x error / 2 x limit values (configurable)	
Synchronization		possible for simultaneous or alternating measurements	
Connection		integrated pigtail 0.25 m with 14-pin ODU plug, min. bending radius 30 mm (see accessories for suitable connection cable)	
Mounting		Screw connection via three mounting holes	
Temperature range	Storage	-20 ... +70 °C (non-condensing)	
	Operation	0 ... +50 °C (non-condensing)	
Shock (DIN EN 60068-2-27)		15 g / 6 ms in 3 axes	
Vibration (DIN EN 60068-2-6)		2 g / 20 ... 500 Hz	
Protection class (DIN EN 60529)		IP65	
Material		Aluminum housing	
Weight		approx. 800 g (incl. pigtail)	
Control and display elements		Select & function keys: output type, measuring rate, type of averaging, averaging number, error analog, synchronization, operation mode, trigger mode, baud rate, data format; measurement chart via PC using the ILD1700 Tool; 5 x color LEDs for status display	

FSO = Full Scale Output

SMR = Start of measuring range, MMR = Mid of measuring range, EMR = End of measuring range



The specified data apply to white, diffuse reflecting surfaces (Micro-Epsilon reference ceramic for ILD sensors)

¹⁾ Measuring rate of 2.5 kHz, without averaging

²⁾ USB optional via cable PC 1700-3/USB (see accessories)



Laser sensors for large measuring ranges optoNCDT 1750-500 / 1750-750

-  For common surfaces
-  Measuring rate up to 7.5 kHz
- INTERFACE** Analog (U/I) / RS422 / PROFINET / EtherNet/IP
- RTSC** Real Time Surface Compensation
-  Repeatability 20 μm



The optoNCDT 1750 is a powerful laser triangulation sensor which is used in high speed, precise measurements with large measuring ranges. Thanks to innovative evaluation algorithms, the laser sensor provides high accuracy and dynamics. The high-performance optical system generates a small light spot onto the target which enables the detection of even the smallest of components reliably.

The optoNCDT 1750 offers the real time surface compensation (RTSC) feature which determines the amount of reflection from the target surface during continuous exposure and in real-time. The exposure time or the amount of light produced by the laser is optimally matched to the reflection characteristics of the target surface. This enables extremely reliable measurements even on reflecting surfaces.

Different output signals enable the sensor to be integrated into plant and machine control systems. As well as analog voltage and current outputs, a digital RS422 interface provides distance information from the sensor. All optoNCDT 1750 models are operated using an intuitive web interface. Due to the comprehensive setting and evaluation possibilities, the optoNCDT 1750 meets the requirements for use in industrial applications with high dynamics.

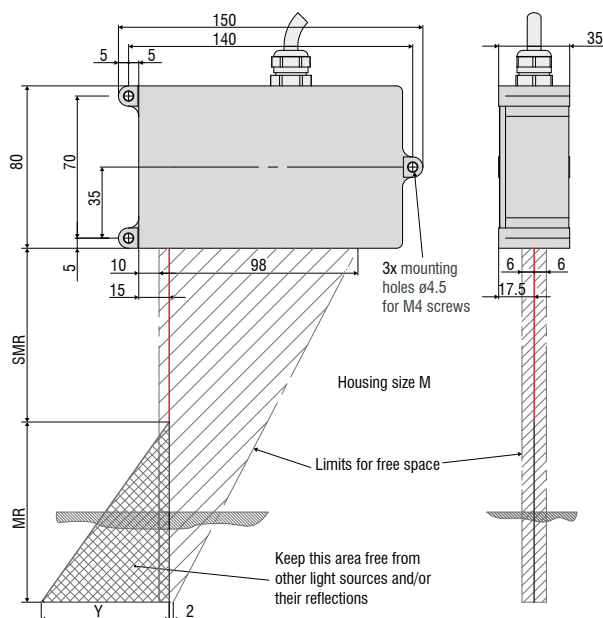

MR	SMR	Y
500	200	180
750	200	270

Model		ILD1750-500	ILD1750-750
Measuring range		500 mm	750 mm
Start of measuring range		200 mm	200 mm
Mid of measuring range		450 mm	575 mm
End of measuring range		700 mm	950 mm
Measuring rate ¹⁾		continuously adjustable between 0.3 ... 7.5 kHz	
		6 adjustable stages: 7.5 kHz / 5 kHz / 2.5 kHz / 1.25 kHz / 625 Hz / 300 Hz	
Linearity		< ±350 μm	< ±670 μm
		< ±0.07 % FSO	< ±0.09 % FSO
Repeatability ²⁾		20 μm	30 μm
Light spot diameter (±10 %)	SMR	1300 μm	1500 μm
	MMR		
	EMR		
Light source		Semiconductor laser < 1 mW, 670 nm (red)	
Laser safety class		Class 2 in accordance with DIN EN 60825-1: 2015-07	
Permissible ambient light		10,000 lx	
Supply voltage		11 ... 30 VDC	
Power consumption		< 3 W (24 V)	
Signal input		1 x HTL/TTL laser on/off; 1 x HTL/TTL multi-function input: trigger in, slave in, zero setting, mastering, teach-in; 1 x RS422 synchronization input: trigger in, sync in, master/slave, master/slave alternating	
Digital interface		RS422 (16 bit) / PROFINET ³⁾ / EtherNet/IP ³⁾	
Analog output		4 ... 20 mA / 0 ... 5 V / 0 ... 10 V (16 bit, freely scalable within the measuring range)	
Switching output		2x switching outputs (error & limit value): npn, pnp, push pull	
Synchronization		possible for simultaneous or alternating measurements	
Connection		integrated pigtail 0.25 m with 14-pin cable connector, min. bending radius 30 mm (fixed installation); optional extension to 3 m / 10 m possible (see accessories for suitable connection cable)	
Mounting		Screw connection via three mounting holes	
Temperature range	Storage	-20 ... +70 °C (non-condensing)	
	Operation	0 ... +50 °C (non-condensing)	
Shock (DIN EN 60068-2-27)		15 g / 6 ms in 3 axes	
Vibration (DIN EN 60068-2-6)		2 g / 20 ... 500 Hz	
Protection class (DIN EN 60529)		IP65	
Material		Aluminum housing	
Weight		approx. 600 g (incl. pigtail)	
Control and display elements		Select & function keys: interface selection, mastering (zero), teach, presets, quality slider, frequency selection, factory settings; web interface for setup ⁴⁾ : application-specific presets, peak selection, video signal, freely selectable averaging possibilities, data reduction, setup management; 2 x color LEDs for power / status	

FSO = Full Scale Output

SMR = Start of measuring range, MMR = Mid of measuring range, EMR = End of measuring range

The specified data apply to white, diffuse reflecting surfaces (Micro-Epsilon reference ceramic for ILD sensors)

¹⁾ Factory setting 5 kHz, modifying the factory setting requires the IF2001/USB converter (see accessories)

²⁾ Measuring rate 5 kHz, median 9

³⁾ Optional connection via interface module (see accessories)

⁴⁾ Connection to PC via IF2001/USB (see accessories)

Model	ILD2310-10	ILD2310-20	ILD2310-40	ILD2310-50
Measuring range ¹⁾	10 (5) mm	20 (10) mm	40 (20) mm	50 (25) mm
Start of measuring range ¹⁾	95 (100) mm	90 (100) mm	175 (195) mm	550 (575) mm
Mid of measuring range ¹⁾	100 (102.5) mm	100 (105) mm	195 (205) mm	575 (587.5) mm
End of measuring range ¹⁾	105 (105) mm	110 (110) mm	215 (215) mm	600 (600) mm
Measuring rate	7 adjustable stages: 49.14 kHz ²⁾ / 30 kHz / 20 kHz / 10 kHz / 5 kHz / 2.5 kHz / 1.5 kHz			
Linearity	< ±3 μm	< ±6 μm	< ±12 μm	< ±50 μm
	< ±0.03 % FSO			< ±0.1 % FSO
Resolution	0.5 μm	1 μm ³⁾	2 μm	7.5 μm
Light spot diameter (± 10 %)	SMR	200 μm	230 μm	400 ... 500 μm
	MMR	60 μm	210 μm	
	EMR	200 μm	230 μm	
Light source	Semiconductor laser < 1 mW, 670 nm (red)			
Laser safety class	Class 2 in accordance with DIN EN 60825-1 : 2015-07 / optional class 3R			
Permissible ambient light	10,000...40,000 lx			
Supply voltage	11 ... 30 VDC			
Power consumption	< 3 W (24 V)			
Signal input	Laser on/off, sync in, trigger in			
Digital interface	RS422 (16 bit) / Ethernet / EtherCAT / PROFINET ⁴⁾ / EtherNet/IP ⁴⁾			
Analog output ⁴⁾	4 ... 20 mA / 0 ... 5 V / 0 ... 10 V / ±5 V / ±10 V			
Synchronization	possible for simultaneous or alternating measurements			
Connection	integrated pigtail 0.25 m with 14-pin ODU plug, min. bending radius 30 mm (see accessories for suitable connection cable)			
Mounting	Screw connection via three mounting holes			
Temperature range	Storage	-20 ... +70 °C (non-condensing)		
	Operation	0 ... +50 °C (non-condensing)		
Shock (DIN EN 60068-2-27)	15 g / 6 ms in 3 axes			
Vibration (DIN EN 60068-2-6)	2 g / 20 ... 500 Hz			
Protection class (DIN EN 60529)	IP65			
Material	Aluminum housing			
Weight	approx. 550 g (incl. pigtail)			
Control and display elements	Web interface for setup: user management, measurement settings, data output, measurement control, parameters, extras; 2 x color LEDs for Status / Ethernet and EtherCAT			

FSO = Full Scale Output

SMR = Start of measuring range, MMR = Mid of measuring range, EMR = End of measuring range

The specified data apply to white, diffuse reflecting surfaces (Micro-Epsilon reference ceramic for ILD sensors)

¹⁾ Value in brackets is valid for a measuring rate of 49.14 kHz

²⁾ Measuring rate of 49.14 kHz with reduced measuring range (in brackets)

³⁾ With 10 kHz, without averaging

⁴⁾ Optional connection via interface module (see accessories)

Accessories for all optoNCDT series

Power supply

- PS2020 (power supply 24 V / 2.5 A, input 100 - 240 VAC, output 24 VDC / 2.5 A, mounting onto symmetrical standard rail 35 mm x 7.5 mm, DIN 50022)

Accessories for 1220/1320 series

Protective film

- Transparent protective film 32 x 11 mm for ILD1x20

Accessories for 1420 series

Supply and output cable (drag-chain suitable)

- PCF1420-1/I (1 m, output 4 ... 20 mA)
 - PCF1420-1/I(01) (1 m, output 4...20 mA)
 - PCF1420-3/I (3 m, output 4 ... 20 mA)
 - PCF1420-6/I (6 m, output 4 ... 20 mA)
 - PCF1420-10/I (10 m, output 4 ... 20 mA)
 - PCF1420-15/I (15 m, output 4 ... 20 mA)
 - PCF1420-3/U (3 m, with integrated resistor, output 1 ... 5 VDC)*
 - PCF1420-6/U (6 m, with integrated resistor, output 1 ... 5 VDC)*
 - PCF1420-10/U (10 m, with integrated resistor, output 1 ... 5 VDC)*
 - PCF1420-15/U (15 m, with integrated resistor, output 1 ... 5 VDC)*
 - PCF1420-3/IF2008 (3 m, interface and supply cable)
 - PCF1420-6/IF2008 (6 m, interface and supply cable)
 - PCF1420-10/IF2008 (10 m, interface and supply cable)
 - PCF1420-3/C-Box (3 m)
- * on request with output 2 ... 10 VDC

Supply and output cable, suitable for use with robots

(available in 90° version)

- PCR1402-3/I (3 m)
- PCR1402-6/I (6 m)
- PCR1402-8/I (8 m)

Protective film

Transparent protective film 32 x 11mm for ILD1x20

Accessories for 1710/1750 series

Supply and output cable (drag-chain suitable)

- PC1700-3 (3 m)
- PC1700-10 (10 m)
- PC1700-10/IF2008 (10 m, for use with interface card IF2008)
- PC1750-3/C-Box (3 m)
- PC1750-6/C-Box (6 m)
- PC1750-9/C-Box (9 m)

Supply and output cable (suitable for use with robots)

- PCR1700-5 (5 m)
- PCR1700-10 (10 m)

Supply and output cables for temperatures up to 200 °C

- PC1700-3/OE/HT (3 m)
- PC1700-6/OE/HT (6 m)
- PC1700-15/OE/HT (15 m)

Protective housings

- SGH model (sizes S and M)
- SGHF model (sizes S and M)
- SGHF-HT model

Accessories for 1900 series

Supply and output cable (drag-chain suitable)

- PC1900-3/IF2008 Supply/output cable 3 m
- PC1900-6/IF2008 Supply/output cable 6 m
- PC1900-9/IF2008 Supply/output cable 9 m
- PC1900-15/IF2008 Supply/output cable 15 m
- PC1900-3/C-Box Power/output cable 3 m
- PC1900-6/C-Box Power/output cable 6 m
- PC1900-9/C-Box Power/output cable 9 m
- PC1900-15/C-Box Power/output cable 15 m
- PC1900-3/OE Supply/output cable 3 m
- PC1900-6/OE Supply/output cable 6 m
- PC1900-9/OE Supply/output cable 9 m
- PC1900-15/OE Supply/output cable 15 m

Accessories for 2300/2310 series

Supply and output cable

- PC2300-0,5Y (connection cable to PC or PLC; for operation a PC2300-3/SUB-D will be required in addition)
 - PC2300-3/SUB-D (3 m; for operation a PC2300-0,5Y will be required in addition)
 - PC2300-3/IF2008 (interface and supply cable)
 - PC2300-3/OE (3 m)
 - PC2300-6/OE (6 m)
 - PC2300-9/OE (9 m)
 - PC2300-15/OE (15 m)
 - PC2300-3/C-Box/RJ45 (3 m)
- * other cable lengths on request

Supply and output cables for temperatures up to 200 °C

- PC2300-3/OE/HT (3 m)
- PC2300-6/OE/HT (6 m)
- PC2300-9/OE/HT (9 m)
- PC2300-15/OE/HT (15 m)

Protective housings

- SGH model (sizes S and M)
- SGHF model (sizes S and M)
- SGHF-HT model

sensorTOOL

The Micro-Epsilon sensorTOOL is a powerful software that is used to operate one or more optoNCDT sensors. The sensorTOOL can be used to access the sensor connected to the PC, display its complete data stream and save it in a file (in Excel-compatible CSV format). The sensor is configured via its web interface.

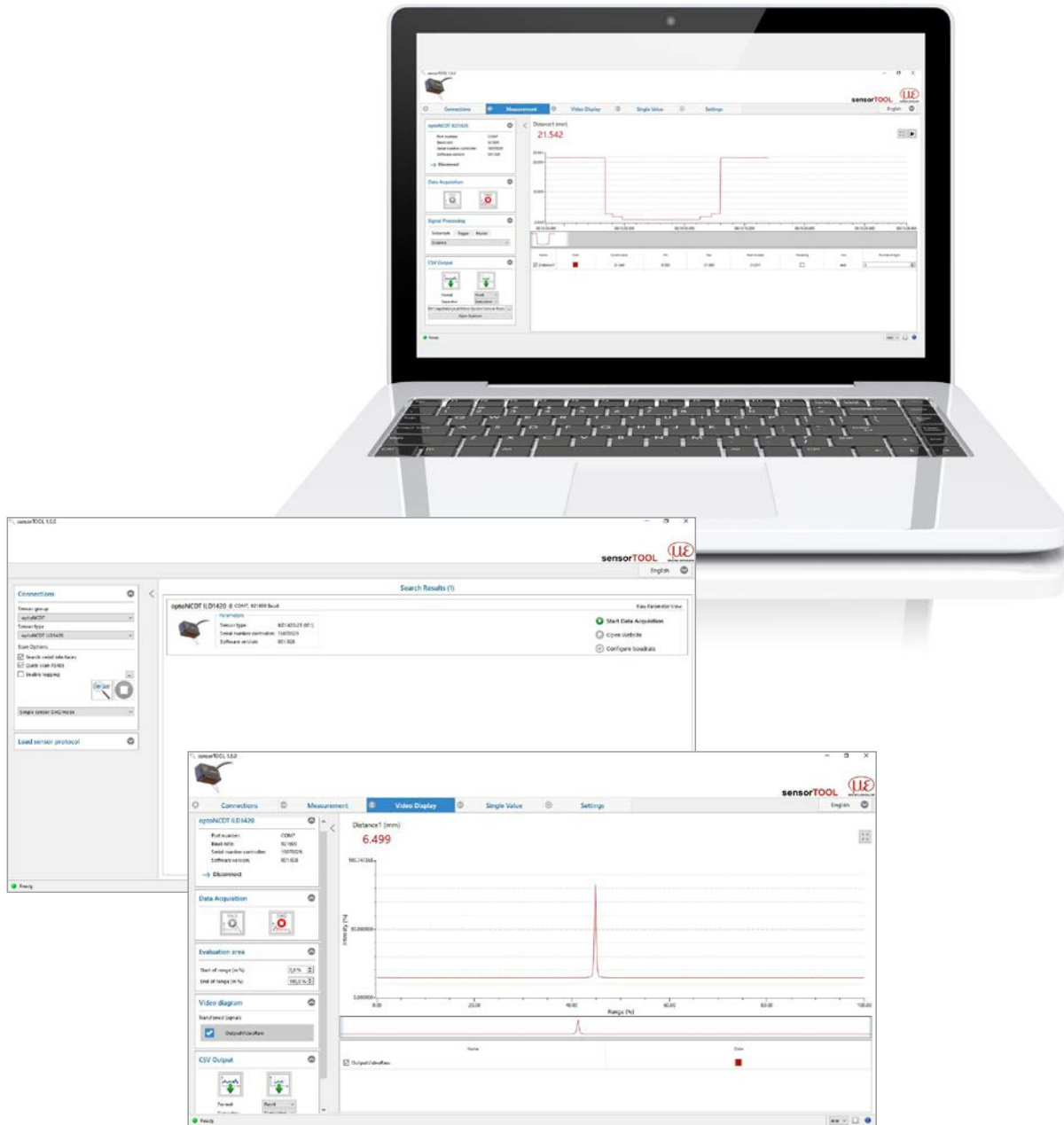

Free download

All software tools, drivers and documented driver DLL for easy integration of the sensors into existing or internally-generated software are available free of charge under www.micro-epsilon.com/download

Accessories

optoNCDT

Protective housings for demanding environments

To protect the optoNCDT laser sensors in harsh environments, protective housings are available in different designs.

SGH model:

The SGH protective housing encloses the sensor and is equipped with a replaceable protective window. The water-resistant housing protects the sensor from solvents and detergents.

Size S for the following models:

- 1750-20BL and 1750-200BL
- 2300-2, 2300-5, 2300-10, 2300-20, 2300-50 and 2300-100
- 2300-2LL, 2300-10LL, 2300-20L and 2300-50LL
- 2300-2BL, 2300-5BL and 2300-10BL

Size M for the following models:

- 1750-500BL and 1750-750BL
- 1750 500 and 1750-750
- 2300-200 and 2300-300
- 2310-10, 2310-20 and 2310-40

SGHF model:

With window and compressed-air connection ideal for high ambient temperatures. The integrated air cooling of the housing offers optimum protection for the sensor.

Size S for the following models:

- 1750-20BL and 1750-200BL
- 2300-2, 2300-5, 2300-10, 2300-20, 2300-50 and 2300-100
- 2300-2LL, 2300-10LL, 2300-20L and 2300-50LL
- 2300-2BL, 2300-5BL and 2300-10BL

Size M for the following models:

- 1750-500BL and 1750-750BL
- 1750 500 and 1750-750
- 2300-200 and 2300-300
- 2310-10, 2310-20 and 2310-40

SGHF-HT model:

This water-cooled protective housing with window and compressed-air connection is designed for measurement tasks in ambient temperatures up to 200 °C.

For the following models:

- 1710-50 and 1710-1000
- 1710-50BL and 1710-1000BL
- 1750-500 and 1750-750
- 1750-500BL and 1750-750BL
- 2300-200 and 2300-300
- 2310-50BL
- 2310-10, 2310-20, 2310-40 and 2310-50

Maximum temperature of cooling water $T(\max) = 10\text{ °C}$

Minimum water flow rate $Q(\min) = 3\text{ liters/min}$



SGH size S (140 x 140 x 71 mm)



SGH size M (180 x 140 x 71 mm)



SGHF size S (140 x 140 x 71 mm)



SGHF size M (180 x 140 x 71 mm)



SGHF-HT (260 x 180 x 154 mm)

Interface modules

Module	optoNCDT 1220	optoNCDT 1320	optoNCDT 1420	optoNCDT 1710	optoNCDT 1750	optoNCDT 1900	optoNCDT 2300	optoNCDT 2310
C-Box/2A Controller unit for evaluation and signal conversion of up to 2 sensor signals	⊘	⊘	✓	⊘	✓	✓	✓	✓
IF2001/USB RS422/USB converter to transform a digital signal to USB	✓	✓	✓	✓	✓	✓	✓	✓
IC2001/USB Single-channel RS422/USB converter cable	✓	✓	✓	✓	✓	✓	✓	✓
IF2004/USB RS422/USB converter to convert up to 4 digital signals to USB	⊘	⊘	✓	✓	✓	✓	✓	✓
IF2008/ETH Interface module for Ethernet connection for up to 8 sensors	⊘	⊘	✓	⊘	✓	✓	✓	✓
IF2008PCIE Interface card for multiple sensor signals; analog and digital interfaces	⊘	⊘	✓	✓	✓	✓	✓	✓
IF2030/PNET Interface module for Industrial Ethernet connection (PROFINET)	✓	✓	✓	⊘	✓	✓	✓	✓
IF2030/ENETIP Interface module for Industrial Ethernet connection (EtherNet/IP)	✓	✓	✓	⊘	✓	✓	✓	✓

C-Box/2A Controller for D/A conversion and evaluation of up to 2 sensor signals

C-Box/2A is used for fast D/A conversion of two digital input signals or for evaluating two digital sensor signals. The controller is compatible with the optoNCDT 1420, 1750, 1900 and 2300 models. Handling of the C-Box/2A and of the connected sensors are performed via web interface. Averaging functions, thickness, diameter, step and inclinations can be calculated. The D/A conversion is executed at 16 bit and max. 70 kHz.



Special features

- Trigger input
- Multi-function output
- Measurement value output via Ethernet, USB, analog output
4 ... 20 mA / 0 ... 5 V / 0 ... 10 V / ± 5 V / ± 10 V
(scalable via web interface)
- 2x switching outputs for sensors or C-Box/2A status
- Parallel data output via three output interfaces

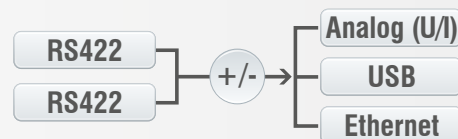

IF2030

Interface module for Industrial Ethernet connection

The IF2030 interface modules are designed for easy connection of Micro-Epsilon sensors to Ethernet-based fieldbuses, e.g., plant control systems. The PROFINET and Ethernet/IP modules are compatible with sensors that output data via an RS422 or RS485 interface. These modules operate on the sensor side with up to 4 MBd and have two network connections for different network topologies. Installation in control cabinets is via a DIN rail.

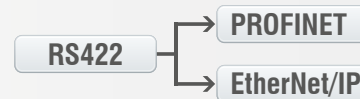

IF2008PCIe/IF2008E

Interface card for synchronous data acquisition

Absolute synchronous data acquisition is a decisive factor for the planarity or thickness measurement using several laser sensors. The IF2008PCIe interface card is designed for installation in PCs and enables the synchronous capture of four digital sensor signals and two encoders. The data is stored in a FIFO memory in order to enable resource-saving processing in blocks in the PC. The IF2008E expansion board enables to detect in addition two digital sensor signals, two analog sensor signals and eight I/O signals.

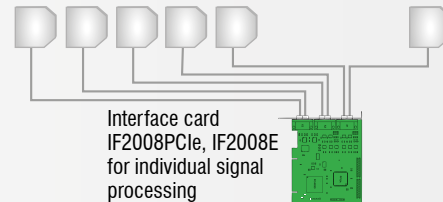
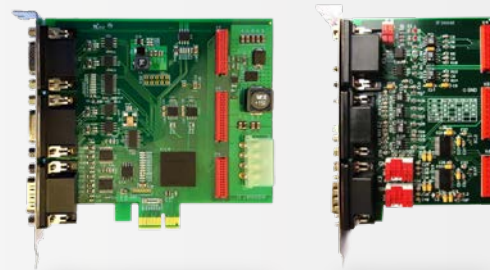

Special features

- IF2008PCIe - Basic printed circuit board:
 - 4 digital signals and 2 encoders
- IF2008E - Expansion board:
 - 2x digital signals, 2x analog signals and 8x I/O signals

IF2008/ETH

IF2008/ETH Interface module for Ethernet connection with up to 8 sensors

The IF2008/ETH integrates up to eight sensors and/or encoders with an RS422 interface into an Ethernet network. Four programmable switching in-/outputs (TTL and HTL logic) are available. Ten indicator LEDs directly on the module show both the channel and the device status. In addition, acquisition and output of data via Ethernet is in addition performed at high speeds up to 200 kHz. Parameter setting of the interface module can be easily done via the web interface.



IC2001/USB Single-channel converter cable RS422/USB

The IC2001/USB single-channel converter cable is used for the USB connection of optoNCDT sensors equipped with an RS422 interface. The cable is easy to assemble and can therefore also be used for installation in machines and systems.

Special features

- 5-core interface cable without outer shield
- Conversion from RS422 to USB
- Easy sensor connection via USB
- Supports baud rates from 9.6 kBaud to 1 MBaud



IF2001/USB converter RS422 to USB

The RS422/USB converter transforms digital signals from a laser-optical sensor into a USB data packet. The sensor and the converter are connected via the RS422 interface of the converter.

Data output is done via USB interface. The converter loops through further signals and functions such as laser on/off, switch signals and function output. The connected sensors and the converter can be programmed through software.

Special features

- Robust aluminum housing
- Easy sensor connection via screw terminals (plug & play)
- Conversion from RS422 to USB
- Supports baud rates from 9.6 kBaud to 12 MBaud



IF2004/USB: 4-channel converter from RS422 to USB

The RS422/USB converter is used for transforming digital signals from up to four optical sensors into USB data signals. The converter has four trigger inputs and a trigger output for connecting additional converters. Data is output via an USB interface. The connected sensors and the converter can be programmed through software.

Special features

- 4x digital signals via RS422
- 4x trigger inputs, 1x trigger output
- Synchronous data acquisition
- Data output via USB

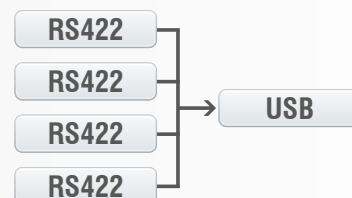

Sensors and Systems from Micro-Epsilon



Sensors and systems for displacement, distance and position



Sensors and measurement devices for non-contact temperature measurement



Measuring and inspection systems for metal strips, plastics and rubber



Optical micrometers and fiber optics, measuring and test amplifiers



Color recognition sensors, LED analyzers and inline color spectrometers



3D measurement technology for dimensional testing and surface inspection