



SCIGATE AUTOMATION (S) PTE LTD

No. 1 Bukit Batok Street 22 #01-01 Singapore 659592

Tel: (65) 6561 0488

Fax: (65) 6562 0588

Email: sales@scigate.com.sg

Web: www.scigate.com.sg

Business Hours: Monday - Friday 8.30am - 6.15pm

Talyrond 131 and 130

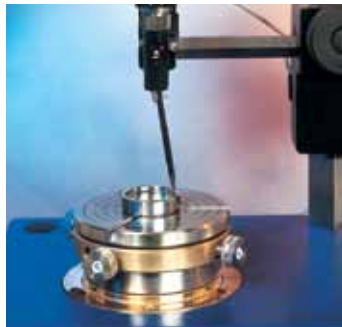

Talyrond 131 and 130

For economical, high precision inspection of roundness and circular geometry.

Process control right at the point of manufacture is cost effective and convenient. Correlation between multiple units is assured thanks to exacting specifications.

Quality control at a central inspection station or in the gauge room is comprehensive and in full accordance with international metrology standards.

Measuring excellence

The degree of excellence for any gauging device is its range to resolution. Taylor Hobson gauge heads, with wide range and selectable resolution, vastly improve the measure of precision in your manufacturing process.

- Wide range - 2mm (0.078")
- simplifies initial set-up of the component and eliminates the need for special fixtures
- Normal resolution - 30nm (1.18μ") - is ideal for most measurement requirements
- High resolution - 6nm (0.24μ") - used when component deviations are less than 0.40mm (0.016")



wide range gauge with wrist assembly provides high resolution in any attitude or orientation



Talyrond 131 shown with optional connecting rod loading platform which allows for comparison of the pin bore axis to the crank bore axis. Customized workholding devices can be used to expand capability (as above) or simply increase throughput.

Powered by ultra Roundness software

ultra software provides comprehensive analysis and programmable measurement capabilities for the Talyrond 131 and 130 instruments. It is the ideal tool for any environment where rapid component inspection is desired.

World leading performance

Both Talyrond 130 and Talyrond 131 incorporate a number of industry leading features that combine to deliver high accuracy, repeatability and ease of use.

Mechanical excellence throughout the measuring loop

Diamond turned air bearing spindle

Spindle accuracy is crucial to the performance of any roundness instrument. Radial limit of error is a constant value measured at the table top. Coning error, how well the spindle rotates on its axis, increases relative to distance above the table top. Although radial error can be improved through software correction, coning error can be minimized only through meticulous construction. Taylor Hobson's ultra high precision spindle provides the best combination of precision and "stiffness" in the world. The result is coning error less than $0.00025\mu\text{m}/\text{mm}$ ($0.25\mu"/\text{inch}$).

Versatile gauging

The measuring gauge is carried in a "wrist" assembly for rapid changeover between vertical and horizontal attitudes while maintaining the exact center point of the stylus contact ball. Vertical for internal and external surfaces; horizontal for surfaces which may be upper or lower, external, angled or conical.

High density zinc alloy base

Compact design is important for the workshop where tabletop space is always at a premium. Taylor Hobson uses a special zinc alloy casting to assure that small size does not compromise performance. This dense material is extremely stable even under typical production floor conditions.

Integrated vibration isolation

As a further guarantee that laboratory grade metrology is attained on the shop floor, vibration isolation pads are built into both the Talyrond 130 and 131 instruments. In all but extreme circumstances no additional anti-vibration materials are required.

Engineering assisted center and leveling

The centering and leveling knobs are differentiated by look and feel, allowing operators to view the screen while setting the component to the spindle axis. In addition, the neutral tilting plane is at a height above the tabletop that facilitates the leveling of both short and tall components.

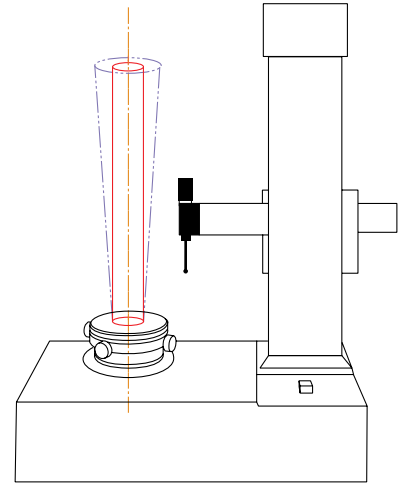

tall components can be measured with confidence and accuracy because coning error is minimized to a remarkable $0.00025\mu\text{m}/\text{mm}$ ($0.25\mu"/\text{inch}$)



gauge arm in horizontal attitude with orientation downward to measure top face



gauge arm in vertical attitude with orientation retracted to measure an inside diameter

Serving a global market

Taylor Hobson is world renowned as a manufacturer of precision measuring instruments used for inspection in research and production facilities. Our equipment performs at nanometric levels of resolution and accuracy.

To complement our precision manufacturing capability we also offer a host of metrology support services to provide our customers with complete solutions to their measuring needs and total confidence in their results.

Contracted Services from Taylor Hobson

- **Inspection services**
measurement of your production parts by skilled technicians using industry leading instruments in accord with ISO standards
- **Metrology training**
practical, hands-on training courses for roundness and surface finish conducted by experienced metrologists
- **Operator training**
on-site instruction will lead to greater proficiency and higher productivity
- **UKAS Calibration and Testing**
certification for artifacts or instruments in our laboratory or at customer's site

For the above services, contact our Center of Excellence:
email: taylor-hobson.cofe@ametek.com
or call: **+44 116 276 3779**

- **Design engineering**
special purpose, dedicated metrology systems for demanding applications
- **Precision manufacturing**
contract machining services for high precision applications and industries
- **Preventative maintenance**
protect your metrology investment with a Talycare service cover plan

For the above services, contact our Sales Department:
email: taylor-hobson.sales@ametek.com
or call: **+44 116 246 2034**



Taylor Hobson UK

(Global Headquarters)
PO Box 36, 2 New Star Road
Leicester, LE4 9JQ, England
Tel: +44 116 276 3771 Fax: +44 116 246 0579
email: taylor-hobson.uk@ametek.com



Taylor Hobson France

Rond Point de l'Épine Champs
Batiment D, 78990 Elancourt, France
Tel: +33 130 68 89 30 Fax: +33 130 68 89 39
taylor-hobson.france@ametek.com



Taylor Hobson Germany

Postfach 4827, Kreuzberger Ring 6
65205 Wiesbaden, Germany
Tel: +49 611 973040 Fax: +49 611 97304600
taylor-hobson.germany@ametek.com



Taylor Hobson India

1st Floor, Prestige Featherlite Tech Park
148, EPIP II Phase, Whitefield, Bangalore – 560 006
Tel: +91 1860 2662 468 Fax: +91 80 6782 3232
taylor-hobson.india@ametek.com



Taylor Hobson Italy

Via De Barzi
20087 Robecco sul Naviglio, Milan, Italy
Tel: +39 02 946 93401 Fax: +39 02 946 93450
taylor-hobson.italy@ametek.com



Taylor Hobson Japan

3F Shiba NBF Tower, 1-1-30, Shiba Daimon Minato-ku
Tokyo 105-0012, Japan
Tel: +81 (0) 3 6809-2406 Fax: +81 (0) 3 6809-2410
taylor-hobson.japan@ametek.com



Taylor Hobson Korea

#310, Gyeonggi R&DB Center, 906-5, Iui-dong
Yeongtong-gu, Suwon, Gyeonggi, 443-766, Korea
Tel: +82 31 888 5255 Fax: +82 31 888 5256
taylor-hobson.korea@ametek.com



Taylor Hobson China Beijing Office

Western Section, 2nd Floor, Jing Dong Fang Building (B10)
No.10, Jiu Xian Qiao Road, Chaoyang District, Beijing, 100015, China
Tel: +86 10 8526 2111 Fax: +86 10 8526 2141
taylor-hobson.beijing@ametek.com

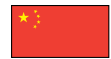

Taylor Hobson China Shanghai Office

Part A, 1st Floor, No. 460 North Fute Road
Waigaoqiao Free Trade Zone, Shanghai, 200131, China
Tel: +86 21 5868 5111-110 Fax: +86 21 5866 0969-110
taylor-hobson.shanghai@ametek.com



Taylor Hobson Singapore

AMETEK Singapore, 10 Ang Mo Kio Street 65
No. 05-12 Techpoint, Singapore 569059
Tel: +65 6484 2388 Ext 120 Fax: +65 6484 2388 Ext 120
taylor-hobson.singapore@ametek.com



Taylor Hobson USA

1725 Western Drive
West Chicago, Illinois 60185, USA
Tel: +1 630 621 3099 Fax: +1 630 231 1739
taylor-hobson.usa@ametek.com



www.taylor-hobson.com