



More Precision

wireSENSOR // Draw-wire displacement sensors





- Robust plastic housing
- Customised versions for OEM
- Wire/hybrid potentiometer

Model MK46 Output P10/P25

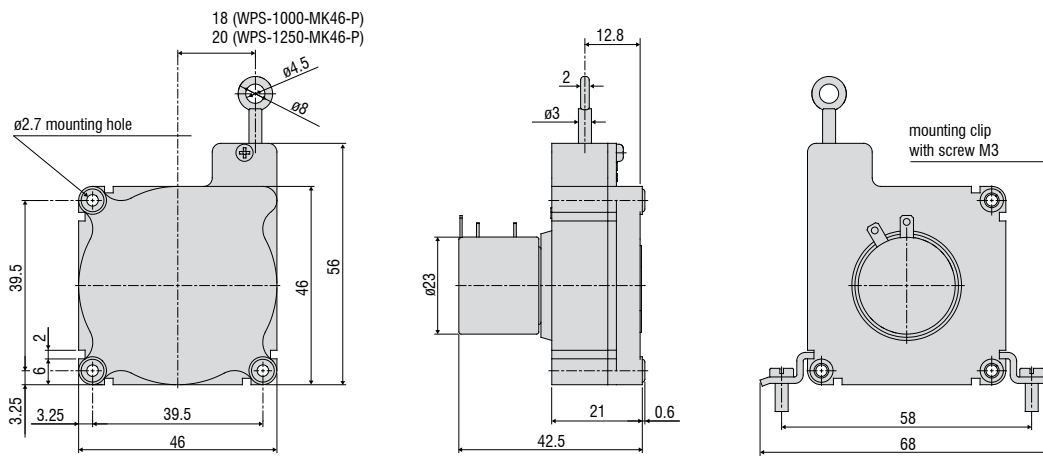

Model MK46 Output CR-P25

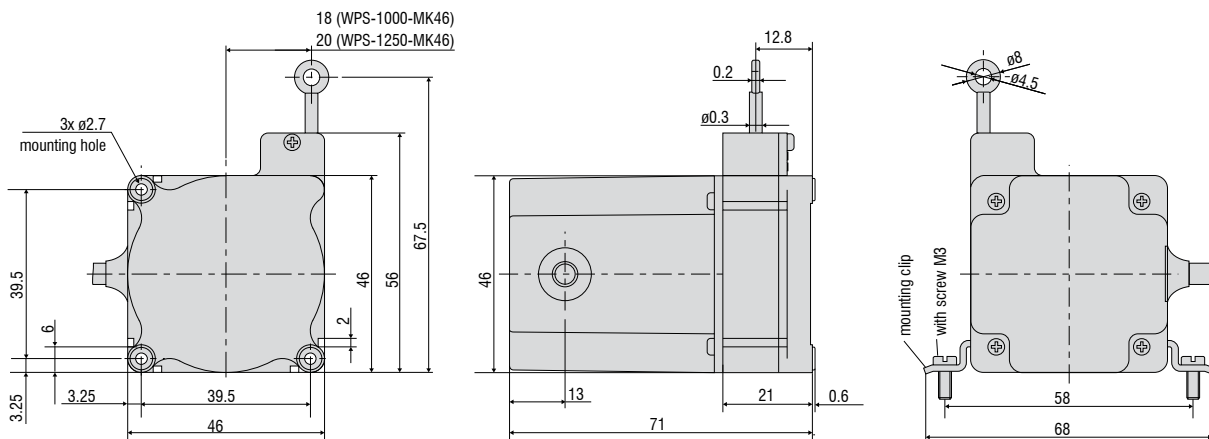

Model	WPS-1000-MK46		WPS-1250-MK46	
Output	P		P/U/I	
Measuring range	1000mm		1250mm	
Linearity	wire pot. P25	±0.25% FSO	±2.5mm	±3.12mm
	Hybridpot. P10/U10/I10	±0.1% FSO	±1mm	±1.2mm
Resolution	wire pot. P25	0.3mm	0.4mm	
	Hybridpot. P10/U10/I10	quasi infinite		
Sensor element	wire/hybrid potentiometer			
Temperature range	-20 ... +80°C			
Material	housing	plastic		
	draw wire	coated polamide stainless steel (ø 0.36mm)		
Wire mounting	eyelet			
Sensor mounting	mounting holes / mounting grooves			
Wire acceleration	appr. 5g			
Wire retraction force (min)	appr. 1N			
Wire extension force (max)	1.6N		1.5N	
Protection class	IP 20			
Electrical connection	P10, P25	soldering tag		
	CR-P25/CR-U10/ CR-I10	integrated cable, radial, 1m		
Weight	appr. 80g			

FSO = Full Scale Output
Specifications for analogue outputs on page 47.

Article description

WPS -	1000 -	MK46 -	P25
			Output option: P25: potentiometer P10: potentiometer CR-P25: potentiometer, integrated cable, radial, 1m
			Model MK46
			Measuring range in mm

WPS -	1250 -	MK46 -	P25
			Output option: P25: potentiometer P10: potentiometer CR-P25: potentiometer, integrated cable, radial, 1m CR-U10: voltage, integrated cable, radial, 1m CR-I10: current, integrated cable, radial, 1m
			Model MK46
			Measuring range in mm



- Robust plastic housing
- Customised versions for OEM
- Incremental encoder

Model MK46

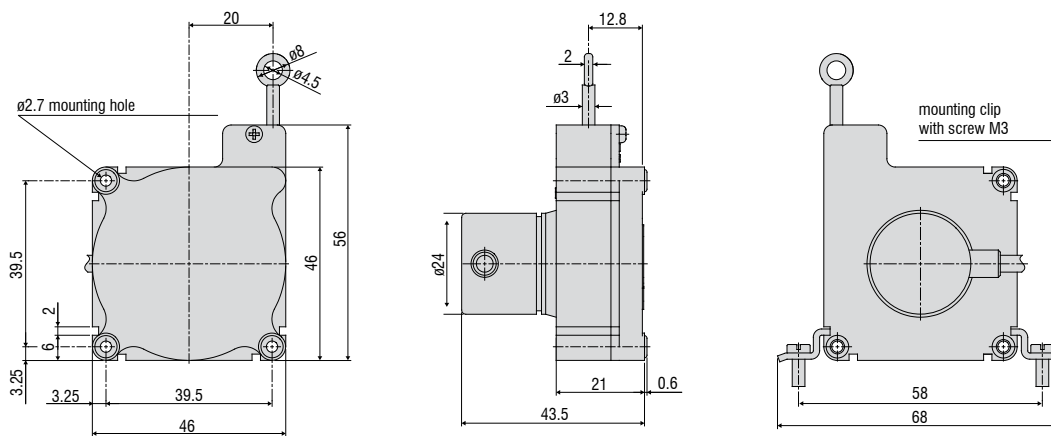

Model	WPS-1250-MK46	
Output	E/E830	
Measuring range	1250mm	
Linearity	±0.05% FSO	encoder
Resolution	4 pulses/mm	
	0.25mm	
Sensor element	incremental encoder	
Temperature range	-20 ... +80°C	
Material	housing	plastic
	draw wire	coated polamide stainless steel (ø 0.36mm)
Wire mounting	eyelet	
Sensor mounting	mounting holes / mounting grooves	
Wire acceleration	appr. 5g	
Wire retraction force (min)	appr. 1N	
Wire extension force (max)	1.5N	
Protection class	IP54	
Electrical connection	cable radial, 1m	
Weight	appr. 120g	

FSO = Full Scale Output

Specifications for digital outputs on page 48.

Article description

WPS -	1250 -	MK46 -	E
			Output option: encoder E (5 ... 24 VDC) encoder E830 (8 ... 30 VDC)
			Model MK46
			Measuring range in mm

Accessories:

WE-xxx-M4	Wire extension with M4-wire connection, x=length
WE-xxx-Clip	Wire extension with eyelet, x=length
TR1-WDS	Pulley wheel, adjustable
TR3-WDS	Pulley wheel, fixed
GK1-WDS	Attachment head for M4
MH1-WDS	Magnetic holder for wire mounting
MH2-WDS	Magnetic holder for sensor mounting
MT-60-WDS	Mounting clamp for WDS-P60
FC8	Female connector for WDS, 8-pin
FC8/90	Female connector 90° for WDS
PC 3/8-WDS	Sensor cable, length 3m
PS 2020	(Power Supply 24 V / 2,5 A, Input 100 - 240 VAC, output 24 VDC / 2.5 A, for snap in mounting on DIN 50022 rail)
WDS-MP60	Mounting plate for P60 sensors

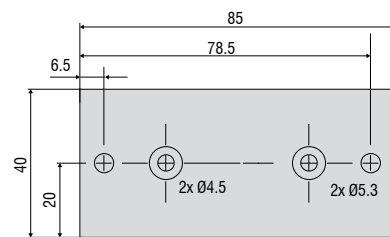
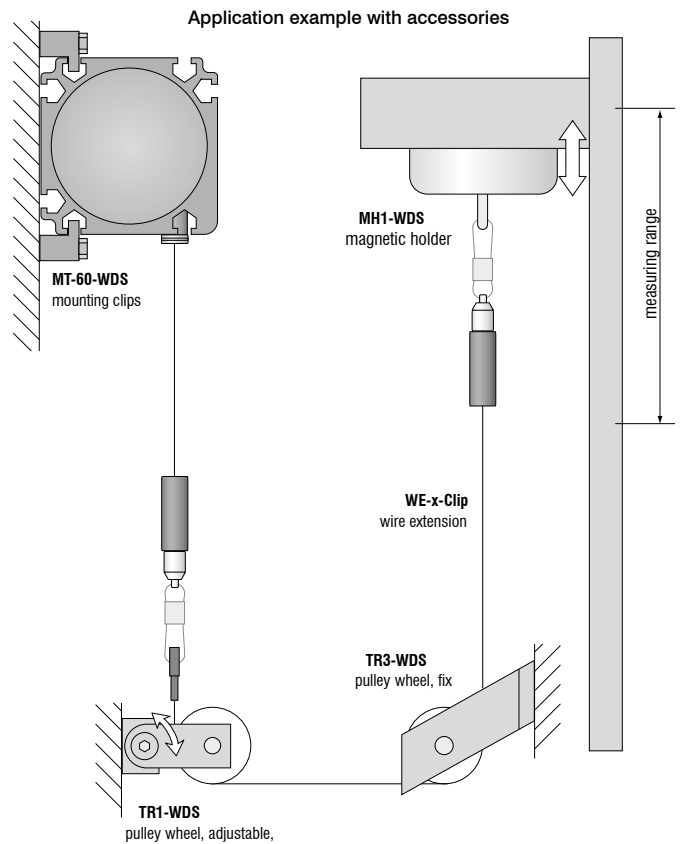

Mounting plate WDS-MP60

Installation information:

Wire attachment: The free return of the measurement wire is not permissible and it is essential that this is avoided during installation.

Wire exit angle:

When mounting a draw-wire displacement sensor, a straight wire exit ($\pm 3^\circ$ tolerance) must be taken into account. If this tolerance is exceeded, increased material wear on the wire and at the wire aperture must be expected.

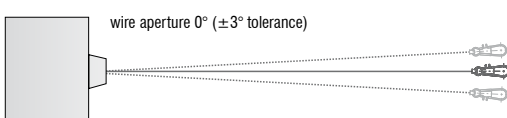

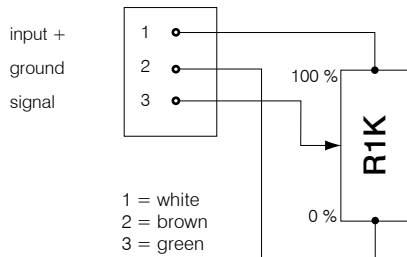

Potentiometric output (P)

Supply voltage	max. 32VDC at 1kOhm / 1 Wmax
Resistance	1kOhm \pm 10% (potentiometer)
Temperature coefficient	\pm 0.0025% FSO/ $^{\circ}$ C
Sensitivity	depends on measuring range individually shown on test report

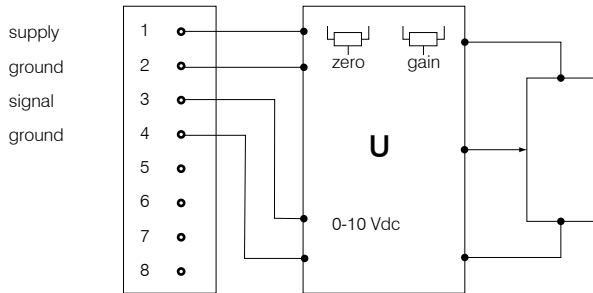

Voltage output (U)

Supply voltage	14 ... 27VDC (non stabilised)
Current consumption	max. 30mA
Output voltage	0 ... 10VDC Option 0 ... 5 / \pm 5V
Load impedance	>5kOhm
Signal noise	0.5mV _{eff}
Temperature coefficient	\pm 0.005% FSO/ $^{\circ}$ C
Electromagnetic compatibility (EMC)	EN 50081-2 EN 50082-2

Adjustment ranges

Zero	\pm 20% FSO
Sensitivity	\pm 20%

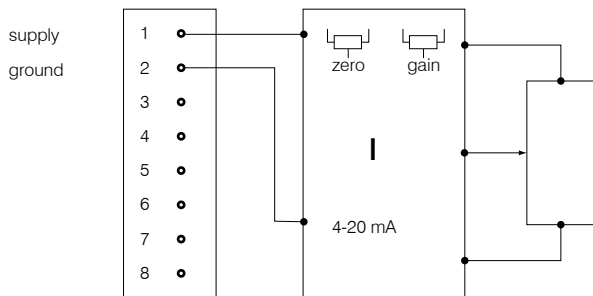

Current Output (I)

Supply voltage	14 ... 27VDC (non stabilised)
Current consumption	max. 35mA
Output current	4 ... 20mA
Load	<600Ohm
Signal noise	<1.6 μ Aeff
Temperature coefficient	\pm 0.01% FSO/ $^{\circ}$ C
Electromagnetic compatibility (EMC)	EN 50081-2 EN 50082-2

Adjustment range

Zero	\pm 18% FSO
Sensitivity	\pm 15%

Contact description

1 UB	Encoder power supply connection
2 GND	Encoder ground connection. The voltage drawn to GND is UB.
3 Pulses +	Positive SSI pulse input. Pulse + forms a current loop with pulse -. A current of approx. 7 mA in direction of pulse + input generates a logical 1 in positive logic.
4 Data +	Positive, serial data output of the differential line driver. A High level at the output corresponds to logical 1 in positive logic.
5 ZERO	Zero setting input for setting a zero point at any desired point within the entire resolution. The zeroing process is triggered by a High pulse (pulse duration ≥ 100 ms) and must take place after the rotating direction selection (UP/DOWN). For maximum interference immunity, the input must be connected to GND after zeroing.
6 Data -	Negative, serial data output of the differential line driver. A High level at the output corresponds to logical 0 in positive logic.
7 Pulses -	Negative SSI pulse input. Pulse - forms a current loop with pulse +. A current of approx. 7 mA in direction of pulse - input generates a logical 0 in positive logic.
8 / 10 <u>DATAVALID</u> <u>DATAVALID MT</u>	Diagnosis outputs DV and DV MT Jumps in data word, e.g. due to defective LED or photoreceiver, are displayed via the DV output. In addition, the power supply of the multiturn sensor unit is monitored and the DV MT output is set when a specified voltage level is dropped below. Both outputs are Low-active, i.e. are switched through to GND in the case of an error.
9 UP/DOWN	UP/DOWN counting direction input. When not connected, this input is on High. UP/ DOWN-High means increasing output data with a clockwise shaft rotating direction when looking at the flange. UP/ DOWN-Low means increasing values with a counter-clockwise shaft rotating direction when looking at the flange.
11 / 12	Not in use

Pin assignment

Pin	Cable colour	Assignment
1	brown	UB
2	black	GND
3	blue	Pulses +
4	beige	Data +
5	green	ZERO
6	yellow	Data -
7	violet	Pulses -
8	brown/yellow	<u>DATAVALID</u>
9	pink	UP/ DOWN
10	black/yellow	<u>DATAVALID</u> <u>MT</u>
11	-	-
12	-	-

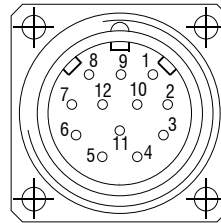

Please use leads twisted in pairs for extension cables.

Inputs

Control signals UP/DOWN and Zero

Level High > 0.7 UB

Level Low < 0.3 UB

Connection: UP/DOWN input with 10kohms to UB, zeroing input with 10kohms to GND.

SSI pulse

Optocoupler inputs for electrical isolation

Outputs

SSI data RS485 driver

Diagnostic outputs

Push-pull outputs are short-circuit-proof

Level High > UB -3.5V (with I = -20mA)

Level Low $\leq 0.5V$ (with I = 20mA)

CANopen features	
Bus protocol	CANopen
Device profile	CANopen - CiA DSP 406, V 3.0
CANopen Features	Device Class 2, CAN 2.0B
Operating modes (with SDO progr.)	<p>Polling Mode (asynch, via SDO)</p> <p>Cyclic Mode (asynch-cyclic) The encoder cyclically sends the current process actual value without a request by a master. The cycle time can be parameterised for values between 1 and 65535 ms.</p> <p>Synch Mode (synch-cyclic) The encoder sends the current actual process value after receiving a synch telegram sent by a master. The synch counter in the encoder can be parameterised so that the position value is not sent until after a defined number of synch telegrams.</p> <p>Acyclic Mode (synch-acyclic)</p>
Preset value	With the "Preset" parameter the encoder can be set to a desired actual process value that corresponds to the defined axis position of the system. The offset value between the encoder zero point and the mechanical zero point of the system is saved in the encoder.
Rotating direction	With the operating parameter the rotating direction in which the output code is to increase or decrease can be parameterised. Scaling The steps per revolution and the total revolution can be parameterised.
Scaling	The steps per revolution and the total revolution can be parameterised.
Diagnose	The encoder supports the following error messages: - Position and parameter error - Lithium cell voltage at lower limit (Multiturn)
Default setting	50kbit/s, node number 1

Baud rate	Setting Dip Switch		
	1	2	3
10kBit/s	OFF	OFF	OFF
20kBit/s	OFF	OFF	ON
50kBit/s	OFF	ON	OFF
125kBit/s	OFF	ON	ON
250kBit/s	ON	OFF	OFF
500kBit/s	ON	OFF	ON
800kBit/s	ON	ON	OFF
1MBit/s	ON	ON	ON

Contact description CANopen	
CAN_L	CAN Bus Signal (dominant Low)
CAN_H	CAN Bus Signal (dominant High)
UB	Supply voltage 10...30VDC
GND	Ground contact for UB
(Terminals with the same designation are internally interconnected)	

Settings of user address for CANopen
 Address can be set with rotary switch. Example: User address 23

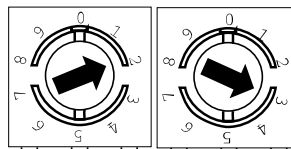
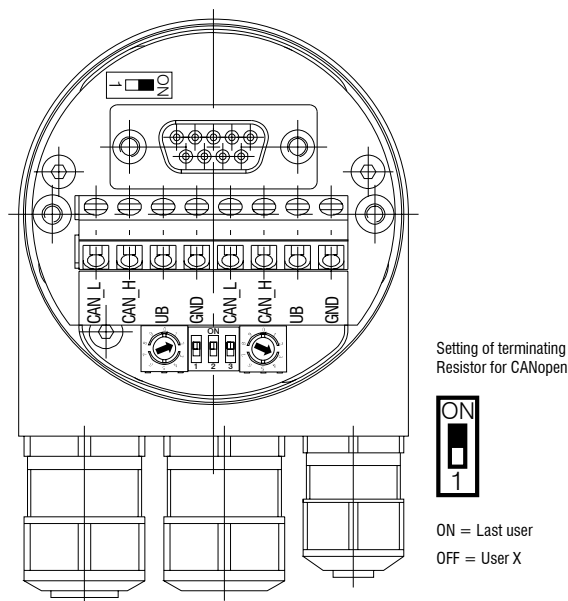

Profibus-DP features

Bus protocol	Profibus-DP
Profibus features	Device Class 1 and 2
Data exch. functions	Input: Position value Additional parameterised speed signal (readout of the current rotary speed) Output: Preset value
Preset value	With the "Preset" parameter the encoder can be set to a desired actual value that corresponds to the defined axis position of the system.
Parameter functions	Rotating direction: With the operating parameter the rotating direction for which the output code is to increase or decrease can be parameterised.
Diagnose	The encoder supports the following error messages: - Position error - Lithium cell voltage at lower limit (Multiturn)
Default setting	User address 00

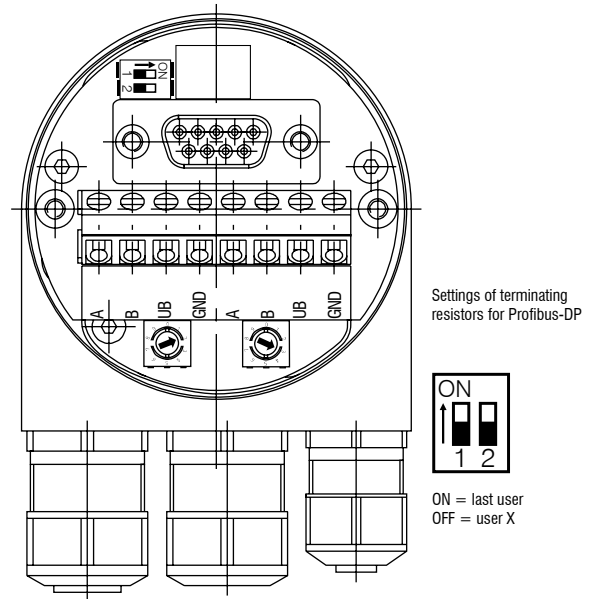
**Settings of user address for Profibus-DP**

Settings of user address for Profibus-DP

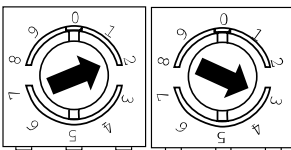
**Contact description Profibus-DP**

A Negative serial data line

B Positive serial data line

UB Supply voltage 10...30VDC

GND Ground contact for UB

(Terminals with the same designation are internally interconnected)

Signal output

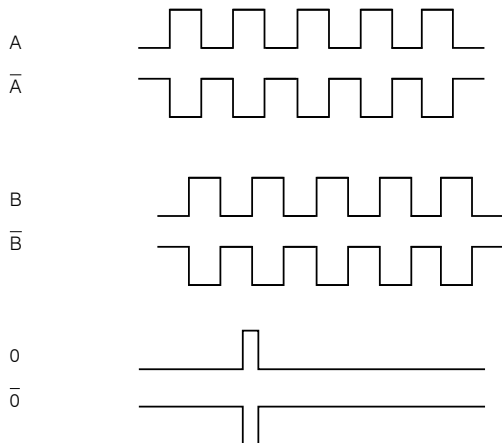

Output TTL	Linedriver (5 VDC)	
Level High	$\geq 2.5V$	(with I = -20mA)
Level Low	$\leq 0.5V$	(with I = 20mA)
Load High	$\leq 20mA$	
Output	A, A-bar, B, B-bar, 0	

Output HTL	Push-pull (10 ... 30 VDC)	
Level High	$\geq UB - 3V$	(with I = -20mA)
Level Low	$\leq 1.5V$	(with I = 20mA)
Load High	$\leq 40mA$	
Output	A, A-bar, B, B-bar, 0	

Output E	Push-pull (5 VDC)	
Level High	UB - 2.5V	
Level Low	$\leq 0.5V$	
Load High	$\leq 50mA$	
Output	A, B, 0	

Output E830	Push-pull (8 ... 30 VDC)	
Level High	UB - 3V	
Level Low	$\leq 2.5V$	
Load High	$\leq 50mA$	
Output	A, B, 0	

Pin assignment TTL, HTL

Pin	Cable colour	Assignment
Pin 1	pink	B inv.
Pin 2	blue	UB Sense
Pin 3	red	N (zero impulse)
Pin 4	black	N inv. (zero impulse inv.)
Pin 5	brown	A
Pin 6	green	A inv.
Pin 7	-	-
Pin 8	grey	B
Pin 9	-	-
Pin 10	white/green	GND
Pin 11	white	GND Sense
Pin 12	brown/green	UB

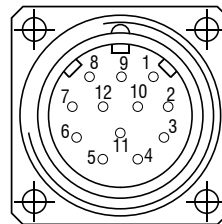

Pin 2 and Pin 12 are internally connected as well as Pin 11 and 10. For cable length > 10m twisted pair wires are required.

Connection assignment E, E830

Pin	Cable colour	Assignment
-	white	0V
-	brown	+UB
-	green	A
-	-	A
-	yellow	B
-	-	B
-	grey	0

High performance sensors made by Micro-Epsilon



Sensors and systems for displacement and position



Sensors and measurement devices for non-contact temperature measurement



2D/3D profile sensors (laser scanner)



Optical micrometers, fibre optic sensors and fibre optics



Colour recognition sensors, LED analysers and colour inline spectrometer



Measurement and inspection systems

**SCIENCE
GATE**
Your Automation Partner



SCIGATE AUTOMATION (S) PTE LTD

No.1 Bukit Batok Street 22 #01-01 Singapore 659592

Tel: (65) 6561 0488

Fax: (65) 6562 0588

Email: sales@scigate.com.sg

Web: www.scigate.com.sg

Business Hours: Monday - Friday 8.30am - 6.15pm



MICRO-EPSILON

MICRO-EPSILON Headquarters
Koenigbacher Str. 15 · 94496 Ortenburg / Germany
Tel. +49 (0) 8542 / 168-0 · Fax +49 (0) 8542 / 168-90
info@micro-epsilon.com · www.micro-epsilon.com

MICRO-EPSILON UK Ltd.
No.1 Shorelines Building · Shore Road · Birkenhead · CH41 1AU
Phone +44 (0) 151 355 6070 · Fax +44 (0) 151 355 6075
info@micro-epsilon.co.uk · www.micro-epsilon.co.uk